

GOVERNMENT POLYTECHNIC, KOLHAPUR – 416004.

(An Autonomous Institute of Govt. Of Maharashtra)

EVEN TERM END EXAM SUMMER -2023**EXAM SEAT NO.**

--	--	--	--	--	--

LEVEL :- **SECOND**PROGRAM : **COMMON**COURSE CODE :- **CCG203/CCF202**COURSE NAME **COMMUNICATION SKILLS**MAX. MARKS : **40** TIME : **02Hrs.**DATE :- **25/05/2023**

Instruction :-

- 1) Answers must be written in the main answer book provided.(and supplements if required)
- 2) Illustrate your answers with sketches wherever necessary.
- 3) Use of non-programmable pocket calculator is permissible.
- 4) Mathematical and other tables shall be made available on request.
- 5) Assume and mention suitable additional data if necessary.
- 6) Use of Mobile is strictly prohibited.
- 7) QN- Question No., SQN-Sub Question No. R- Remembering, U- Understanding, A- Application.

QN	S Q N	Question Text	R/ U/ A	Co CCG 203	Mar ks
Q.1		Attempt any FOUR :			08
	a)	Define oral communication. Give two examples.	U	2	
	b)	State two disadvantages of oral communication.	R	2	
	c)	State two advantages of written communication.	R	3	
	d)	Define the term Kinesics.	R	4	
	e)	Write four examples of written communication.	A	3	
	f)	State importance of appearance and grooming for an interview.	A	6	
Q.2		Attempt any FOUR :			16
	a)	State generation gap and prejudice as psychological barrier in communication. Give suitable examples.	A	1	
	b)	State the types of communication involved in the following situation. Present all the elements in the communication process diagram. Mr. Rohan making an enquiry on mobile with flight booking agent about booking of ticket to Mumbai. The agent confirms the ticket and replies.	U	1	
	c)	Write a short note on planning of media aided presentation.	U	5	
	d)	State the need of oral communication skills for an engineering professional.	U	2	
	e)	Write short note on Mock Interview.	U	6	
	f)	Write precautions one should take when making media aided presentation.	A	5	
Q.3		Attempt any TWO :			16
	a)	Write a letter of application to Crompton Greaves Pvt. India Ltd., Mumbai, for the post of Junior Engineer along with resume.	A	3	
	b)	State the different ways of overcoming language barriers.	U	1	
	c)	The government received an aid from the World Bank for the Welfare of people. The government spent 40% of the amount on building roads, 25% on education 20% on healthcare and 15% for rural development. Draw a pie-chart representing the above data.	A	4	

GOVERNMENT POLYTECHNIC, KOLHAPUR 416004.

(An Autonomous Institute of Govt. of Maharashtra)

EVEN TERM END EXAM SUMMER -2023

EXAM SEAT NO.

--	--	--	--	--	--

LEVEL: THIRD

PROGRAM: CEAME

COURSE CODE: CEG301/MEG301/EEG302/EIG301/CEF301/CE201/EJ201/EEF307/MEF301

COURSE NAME: APPLIED MATHEMATICS

MAX. MARKS: 80

TIME: 3 HRS.

DATE: 24/05/2023

Instruction :-

- 1) Answer must be written in main answer book provided. (and supplements if required)
- 2) Illustrate your answers with sketches where ever necessary.
- 3) Use of non-programmable pocket calculator is permissible.
- 4) Mathematical and other tables will be made available on request.
- 5) Assume and mention suitable additional data necessary.
- 6) Use of Mobile is strictly prohibited.
- 7) **QN**-Question No, **SQN**-Sub-Question No, **R**- Remembering, **U**-Understanding, **A**-Application **CO**-Course outcome

QN	SQN	QUESTION TEXT	R U A	CO CEG301	Marks
Q.1		Attempt any FOUR			(08)
	a	Evaluate $\int \frac{dx}{\sqrt{2x^2 - 8}}$	U	1	
	b	Evaluate $\int \frac{1 - \tan x}{1 + \tan x} dx$	U	1	
	c	Evaluate $\int \frac{\cos(\log x)}{x} dx$	U	1	
	d	Find area bounded by $y = x^3$, x - axis & $x = 1$ & $x = 3$	A	3	
	e	Evaluate $\int_0^{\pi/2} \sin 2x dx$	U	2	
	f	Evaluate $\int_0^1 x^4 \cdot (1+x) dx$	U	2	
Q.2		Attempt any FOUR			(16)
	a	Evaluate $\int_0^{\pi/2} x \cdot \cos x dx$	U	2	
	b	Evaluate $\int_2^3 \frac{\sqrt[3]{x+5}}{\sqrt[3]{x+5} + \sqrt[3]{10-x}} dx$	U	2	
	c	Find area of the circle $x^2 + y^2 = a^2$ by intergration.	A	3	
	d	Evaluate $\int \sin 3x \cdot \cos 2x dx$	U	1	
	e	Evaluate $\int \frac{dx}{2x^2 - 6x - 7}$	U	1	
	f	Evaluate $\int \frac{dx}{3 \cdot \sin^2 x - 2 \cos^2 x + 1}$	U	1	
Q.3		Attempt any FOUR			(16)
	a	Evaluate $\int_0^{\pi/2} \frac{\sin 2x}{8 + 2 \cdot \sin^2 x} dx$	U	2	
	b	Find the area enclosed between the parabola $y^2 = 4x$ & line $2x - y = 4$	A	3	

	c	Find the area enclosed between parabolas $4y^2=9x$ & $3x^2=16y$	A	3	
	d	Evaluate $\int \frac{dx}{5+4.\cos x}$	U	1	
	e	Evaluate $\int \sin^{-1} x dx$	U	1	
	f	Evaluate $\int \frac{dx}{(x-1)(x+2)(2x-1)}$	U	1	
Q.4		Attempt any FOUR			08
	a	Find order and degree of the differential equation $\frac{d^2y}{dx^2} = \left[1 + \left(\frac{dy}{dx} \right)^2 \right]^3$	R	4	
	b	Solve : $(1+x^2) dy - (1+y^2) dx = 0$	R	4	
	c	Find integrating factor of $\frac{dy}{dx} + y \tan x = \cos^2 x$	U	4	
	d	Find L $(3 \cos 6t - 5 \sin 6t)$	R	5	
	e	Find L $(t.\cos 3t)$	R	5	
	f	Find $L^{-1} \left(\frac{6}{3S-2} + \frac{S}{S^2+2} \right)$	R	5	
Q.5		Attempt any FOUR			16
	a	Solve the differential equation $\frac{dx}{dt} = 6-3x$ if $x = 0$ when $t = 0$	A	4	
	b	Solve : $x \log x \frac{dy}{dx} + y = 2 \log x$	U	4	
	c	Solve : $xy dy = (x^2 + y^2) dx$	A	4	
	d	Find L $(t.e^t.\cos t)$	U	5	
	e	Find $L^{-1} \left(\frac{S+1}{S^2+S+1} \right)$	A	5	
	f	Find $L^{-1} \left(\frac{3S+7}{S^2-2S-3} \right)$	A	5	
Q.6		Attempt any FOUR			16
	a	Solve : $(e^x + 2xy^2 + y^3) dx + (a^y + 2x^2y + 3xy^2) dy = 0$	A	4	
	b	Solve : $x(1+y^2) dx + y(1+x^2) dy = 0$	A	4	
	c	Solve : $\frac{dy}{dx} = e^{2x-3y} + 4x^2 e^{-3y}$	A	4	
	d	Find L $[\cos(at+b)]$	U	5	
	e	Find $L^{-1} \left[\frac{s^2+9s+2}{(s-1)^2(s+3)} \right]$	A	5	
	f	Find L $(e^{3t}.\sin 2t.\cos 3t)$	A	5	

15

GOVERNMENT POLYTECHNIC, KOLHAPUR 416004.
 (An Autonomous Institute of Govt. of Maharashtra)
EVEN TERM END EXAM SUMMER -2023

EXAM SEAT NO.

--	--	--	--	--	--

LEVEL: **FIRST**

PROGRAM: **COMMON**

COURSE CODE: **CCG110/CCF110**

COURSE NAME: **Applied Mechanics.**

MAX. MARKS: **80**

TIME: **3 HRS.**

DATE: **03/06/2023**

Instruction:-

- 1) Answer must be written in main answer book provided. (and supplements if required)
- 2) Illustrate your answers with sketches where ever necessary.
- 3) Use of non-programmable pocket calculator is permissible.
- 4) Mathematical and other tables will be made available on request.
- 5) Assume and mention suitable additional data necessary.
- 6) Use of Mobile is strictly prohibited.
- 7) QN-Question No, SQN-Sub-Question No, R- Remembering, U-Understanding, A-Application CO-Course outcome

QN	S Q N	QUESTION TEXT	RU A	CO CCG 110	Marks
Q.1	A	Attempt any FOUR			(08)
	a)	Define force state its SI unit.	R	01	
	b)	Draw neat sketch at coplanar collinear force system and parallel force system.	U	01	
	c)	State properties of couple (any two)	R	01	
	d)	State limitation of Lamis Theorem.	R	02	
	e)	Draw ladder friction diagram with correct notation.	U	02	
	f)	State types at friction.	R	02	
Q.2	A	Attempt any FOUR			(16)
	a)	Two forces 6N & 8N act on a practical and their line at action are inclined to each other at 70° determine resultant reaction in magnitude & direction.	A	01	
	b)	Determine resultant in magnitude and direction of following force system. (Diagram No.1)	A	01	
	c)	Determine support reaction at following beam. (Diagram No. 2)	A	02	
	d)	Enlist different types of beam explain any two with neat sketch.	U	02	
	e)	Determine tension in each rope if weight of 1000N affected by string as show in fig. (Diagram No.3)	A	02	
	f)	A body at 150 N rest on rough horizontal plane it is moved by a horizontal force at 50N determine i) Normal reaction. ii) Coefficient of friction. iii) Resultant reaction. iv) Friction resistance.	A	02	
Q.3		Attempt any FOUR			(16)
	a)	Three parallel forces are act as show in fig. Determine resultant in magnitude and direction with respect to first force (Diagram No.4)	A	02	
	b)	Solve Q3a by graphical method.	A	03	
	c)	A simply supported beam a span 'L' carries a point load 'W' at centre. Determine support reaction offered by beam.	A	02	
	d)	Explain space diagram & vector diagram by neat sketch.	U	03	

P-1/3

P.T.O.

	e)	A block of 1000N resting on rough horizontal plane requires a pull of 400N when it is applied at 30° . Determine coefficient of friction angle of friction & resultant reaction.	A	02	
	f)	A body of weight 300N lying on horizontal plane having coefficient of friction 0.3 Find magnitude of force that can move body while acting at an angle 25° with horizontal.	A	2	
QN	S Q N	QUESTION TEXT	RU A	CO CCG 110	Marks
Q.4		Attempt any FOUR			(08)
	a)	Define centroid for any area.	R	06	
	b)	State or locate the centroid of semicircle and triangle having base b & height h.	U	04	
	c)	State law of conservation of momentum.	R	05	
	d)	Explain with field example "potential energy and Kinetic energy"	U	05	
	e)	Define i) Linear velocity ii) Angular velocity.	R	05	
	f)	Define ideal machine.	R	06	
Q.5		Attempt any FOUR			(16)
	a)	Locate centroid of angle section ISA 150x 100x12mm (L-section)	A	04	
	b)	Locate the position of centroid for a shaded Lamina as shown in (fig.2)	A	04	
	c)	Locate position of centre of gravity of following composite figure	A	05	
	d)	Define momentum and explain Newton's second law of motion.	R	05	
	e)	A fly wheel 200mm diameter speeds from 1000rpm to 5000 rpm in 15 sec. Calculate linear acceleration in m/sec^2 .	A	05	
	f)	A motor car has wheels 800mm dia. accelerates with uniform angular acceleration $1.54 rad/sec^2$. Find out its angular displacement and time required when angular velocity reaches at 600 rpm.	A	05	
Q.6		Attempt any FOUR			(16)
	a)	How may liters of water can be lifted in 20min to height of 30m by means & pump of 2HP?	A	05	
	b)	i) Differentiate between centroid and centre of gravity. (any 2 poits) ii) Differentiate between rectilinear motion and angular motion.	U U	04 05	
	c)	Calculate the workdone in pulling wooden block weighing 200N through 10m up a smooth inclined plane 30° to horizontal.	U	05	
	d)	In certain machine, a load of 1200N is lifted by 60N effort Load move up by 0.6m while effort moves down by 18m. Determine i) M.A ii) V.R. iii) Efficiency iv) Check the reversibility of machine.	A	06	
	e)	A machine lifts a load of 400N and 600N by efforts of 60N and 80N respectively. Determine law of machine and efficiency at a load of 800N if V.R. is 22.	A	06	
	f)	In a machine an effort of 15N can lift a load of 300N & an effort of 25N can lift a load of 500N. Determine the law of machine & also effort required to lift a load of 1000N.	A	06	

Q-2

Sketches [Diagram].

Q 2b Dia No: 1

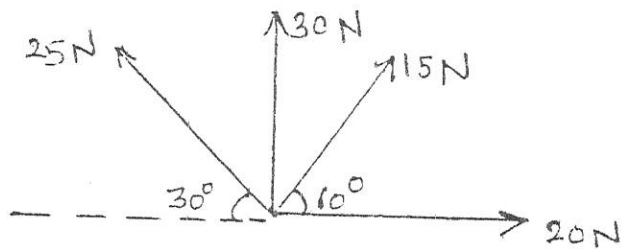

Q 2c Dia No: 2

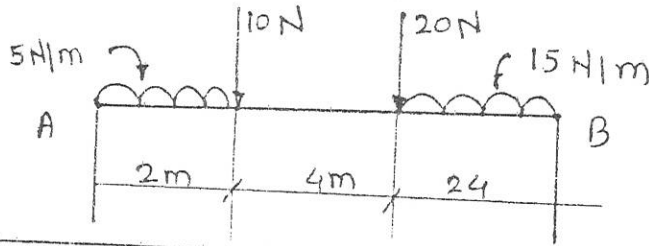

Q 2e Dia No: 3

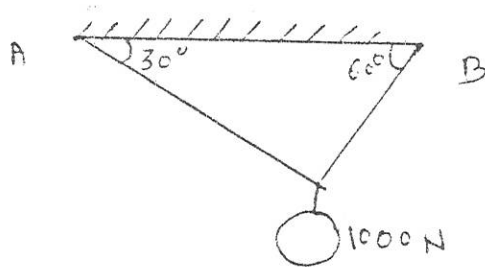

Q 3a Dia No: 4

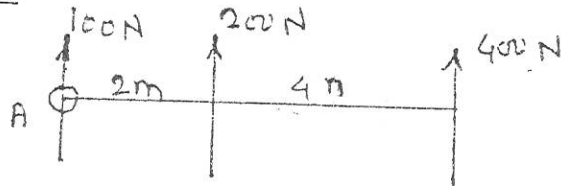

Q. 5(b)

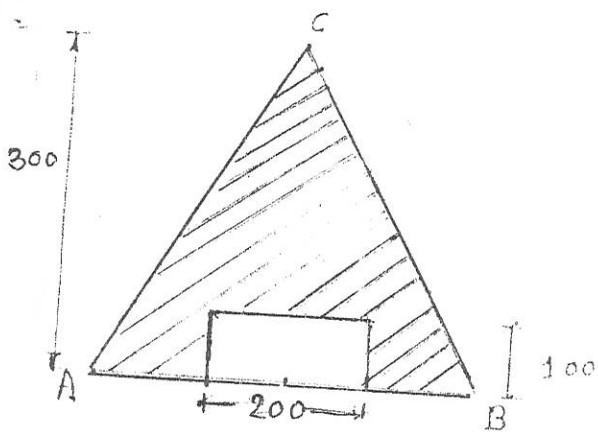

Q. No. 5(b)

Q. 5(c)

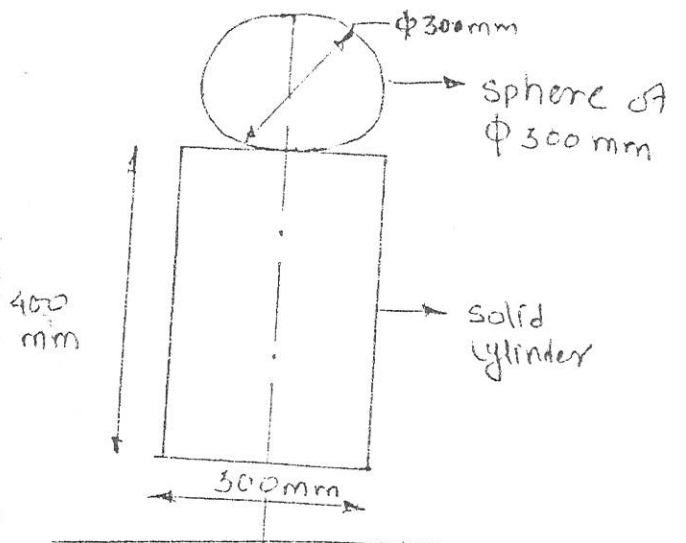

GOVERNMENT POLYTECHNIC, KOLHAPUR – 416004.

(An Autonomous Institute of Govt. Of Maharashtra)

WINTER/SUMMER- 2023

EXAM SEAT NO.

LEVEL :- I

PROGRAM : CE/ME/EE/IE/ET/IT/MT

COURSE CODE :- CCG105/CCF105

COURSE NAME :- BASIC MATHEMATICS

MAX. MARKS : 80 TIME : 03 Hrs DATE :- 09/06/2023

Instruction :-

- 1) Answers of two sections must be written in separate section answer book provided.
- 2) Illustrate your answers with sketches wherever necessary.
- 3) Use of non-programmable pocket calculator is permissible.
- 4) Mathematical and other tables shall be made available on request.
- 5) Assume and mention suitable additional data if necessary.
- 6) Use of Mobile is strictly prohibited.
- 7) QN- Question No., SQN-Sub Question No. R- Remembering, U- Understanding, A- Application.

QN	S Q N	SECTION - I	R/ U/ A	Co	Ma rks
	.1	Attempt any FOUR :			08
	a)	Show that, $\log\left(\frac{145}{49}\right) + \log\left(\frac{14}{29}\right) - \log\left(\frac{10}{7}\right) = 0$	R	1	
	b)	Resolve into partial fraction, $\frac{x-2}{x^2-x}$	U	3	
	c)	Find the value of x if $\begin{vmatrix} 2 & 3 \\ 4 & 5 \end{vmatrix} = \begin{vmatrix} x & 3 \\ 2x & 5 \end{vmatrix}$	U	2	
	d)	Evaluate, $\begin{vmatrix} 5 & 2 & -3 \\ 3 & -1 & 1 \\ -2 & 1 & -2 \end{vmatrix}$	U	2	
	e)	Define unit or identity matrix.	R	4	
	f)	If $A = \begin{bmatrix} 7 & 0 & 2 \\ 1 & 2 & 6 \\ 4 & 5 & 3 \end{bmatrix}$ find whether matrix A is singular or non-singular.	R	4	
	Q.2	Attempt any FOUR :			16
	a)	Prove that, $\frac{1}{\log_2 10} + \frac{1}{\log_4 10} + \frac{1}{\log_{25} 10} + \frac{1}{\log_{50} 10} = 4$	A	1	
	b)	Resolve into partial fraction, $\frac{x^2+1}{x^3+1}$	A	3	
	c)	Resolve into partial fraction, $\frac{x^2}{(x+1)(x+2)(x+3)}$	U	3	
	d)	Using determinant method find x, if $x - 2y + 3z = 4, 2x + y - 3z = 5, -x + y + 2z = 3.$	A	2	
	e)	If $A = \begin{bmatrix} 2 & -3 \\ 3 & 4 \end{bmatrix}, B = \begin{bmatrix} 4 & 5 \\ 3 & -2 \end{bmatrix}, C = \begin{bmatrix} 3 & -1 \\ 0 & 6 \end{bmatrix}$ find $3A + 4B - 2C$	U	4	
	f)	If $A = \begin{bmatrix} -2 & 3 & -1 \\ -1 & 2 & -1 \\ -6 & 9 & -4 \end{bmatrix}$ & $B = \begin{bmatrix} 1 & 3 & -1 \\ 2 & 2 & -1 \\ 3 & 0 & -1 \end{bmatrix}$ verify that $AB = BA = I$ where I is unit matrix of order 3.	U	4	
	Q.3	Attempt any FOUR :			16
	a)	If $A = \begin{bmatrix} 2 & 0 & 3 \\ -1 & 0 & 1 \\ 1 & 1 & 1 \end{bmatrix}$ & $B = \begin{bmatrix} -1 & -1 & 2 \\ 0 & 1 & 0 \\ 2 & 3 & 1 \end{bmatrix}$ verify that $(AB)' = B'A'$	R	4	
	b)	Resolve into partial fraction, $\frac{x^3-5}{x^2-3x+2}$	A	3	
	c)	If $\log\left(\frac{a+b}{3}\right) = \frac{1}{2}(\log a + \log b)$ show that $\frac{a}{b} + \frac{b}{a} = 7$	A	1	
	d)	$A = \begin{bmatrix} -1 & 1 & 1 \\ 2 & 4 & 4 \\ 3 & 2 & 1 \end{bmatrix}$ find adjoint of A.	A	4	
	e)	Resolve into partial fraction, $\frac{e^x+1}{(e^x+2)(e^x+3)}$	A	3	
	f)	Find the inverse of the matrix $\begin{bmatrix} 1 & 2 & 4 \\ -1 & 2 & 3 \\ 1 & 4 & 1 \end{bmatrix}$ using adjoint method.	A	4	

QN	S Q N	QUESTION TEXT	RU A	CO CCG 105	Marks
Q.4		Attempt any FOUR			(08)
	a)	Find the value of $\sin^2 60^\circ + \tan^2 45^\circ - \operatorname{cosec}^2 30^\circ$	R	05	
	b)	Without using calculator find the value of $\sin (-765^\circ)$	R	05	
	c)	Prove that $\sin 2A = 2 \sin A \cos A$	R	05	
	d)	If $\cos A = 0.4$, find the value of $\cos 3A$.	R	05	
	e)	Express as a product. $\sin 4\theta + \sin 2\theta$.	R	05	
	f)	Find the value of $\sin \left[\frac{\pi}{2} - \cos^{-1} \left(\frac{1}{2} \right) \right]$	U	05	
Q.5		Attempt any FOUR			(16)
	a)	Convert the following degree measure into radian measure. i) 30° ii) 270°	R	05	
	b)	If $\cos A = \frac{-3}{5}$ & $\sin B = \frac{20}{29}$, where A & B are the angles in the third & second quadrant respectively. Find $\tan (A+B)$	U	05	
	c)	Prove that : $\frac{\sec 4A - 1}{\sec 2A - 1} = \frac{\tan 4A}{\tan A}$	A	05	
	d)	Prove that: $\frac{\sec A + 2 \sin 3A + \sin 5A}{\sin 3A + 2 \sin 5A + \sin 7A} = \cos 2A - \cot 5A \sin 2A$.	A	05	
	e)	Prove that : $\cos^{-1} \left(\frac{4}{5} \right) + \cos^{-1} \left(\frac{12}{13} \right) = \cos^{-1} \left(\frac{33}{65} \right)$	A	05	
	f)	Prove that, $\tan^{-1}(1) + \tan^{-1}(2) + \tan^{-1}(3) = \pi$	A	05	
Q.6		Attempt any FOUR			(16)
	a)	Prove that $\sin(A+B) \sin(A-B) = \cos^2 B - \cos^2 A$	A	05	
	b)	Prove that : $\sqrt{2\sqrt{2} + \sqrt{2 + 2 \cos 8\theta}} = 2 \cos \theta$	A	05	
	c)	Show that, $\sin 50^\circ - \sin 70^\circ + \sin 10^\circ = 0$	A	05	
	d)	Prove that: $4 \sin A \sin(60^\circ - A) \sin(60^\circ + A) = \sin 3A$	A	05	
	e)	Prove that: $\cos^{-1} \left(\frac{4}{5} \right) - \sin^{-1} \left(\frac{5}{13} \right) = \cos^{-1} \left(\frac{63}{65} \right)$	A	05	
	f)	Prove that: $\tan^{-1} \left(\frac{1}{2} \right) + \tan^{-1} \left(\frac{1}{3} \right) = \frac{\pi}{4}$	A	05	

GOVERNMENT POLYTECHNIC, KOLHAPUR 416004.**(An Autonomous Institute of Govt. of Maharashtra)****EVEN TERM END EXAM SUMMER -2023****EXAM SEAT NO.**

--	--	--	--	--	--

LEVEL: **FIRST**PROGRAM: **CE/ME/MT**COURSE CODE: **CCG106/CCF106/X110**COURSE NAME: **ENGINEERING MATHEMATICS**MAX. MARKS: **80**TIME: **3 HRS.**DATE: **01/06/2023**

Instruction:-

- 1) Answer must be written in main answer book provided. (and supplements if required)
- 2) Illustrate your answers with sketches where ever necessary.
- 3) Use of non-programmable pocket calculator is permissible.
- 4) Mathematical and other tables will be made available on request.
- 5) Assume and mention suitable additional data necessary.
- 6) Use of Mobile is strictly prohibited.
- 7) QN-Question No, SQN-Sub-Question No, R- Remembering, U-Understanding, A-Application CO-Course outcome

QN	S Q N	QUESTION TEXT	RU A	CO CCG 118	Marks
1	A	Attempt any FOUR			(08)
	a)	If $z_1=4-5i$ & $z_2 = 3 + 7i$ Find $ 3z_1 - 3z_2 $	R	01	
	b)	Show that the lines $2x+3y-1=0$ & $3x-2y+6=0$ are perpendicular to each other.	R	02	
	c)	Find the equation of straight line joining the two points (3,4) & (5,6)	R	02	
	d)	Find the probability that a card drawn will be black or picture?	U	03	
	e)	Find the Binomial distribution if the mean is 4 & variance is 3.	A	04	
	f)	Find the probability that a random variable having the standard normal distribution will take on a value between 0.87 & 1.28.	A	04	
Q.2	A	Attempt any FOUR			(16)
	a)	Using De'Movre's theorem, simplify $\frac{(\cos 5\theta - i \sin 5\theta)^{2/5} \left(\cos \frac{2}{5}\theta + i \sin \frac{2}{5}\theta \right)^5}{(\cos 3\theta + i \sin 3\theta)^{1/3} \left(\cos \frac{2}{3}\theta - i \sin \frac{2}{3}\theta \right)^{18}}$	A	01	
	b)	Find the equation of line passing through the point of intersection of the lines $x+y=0$, $2x-y=9$ & passing through the point (2,5)	U	02	
	c)	Find the distance between the parallel lines $3x+4y-5=0$, $6x+8y-45=0$	U	02	
	d)	If 10% bolts produced by a machine are defective, calculate the probability that out of a sample selected at random of 10 bolts, not more than one bolt will be defective.	A	04	
	e)	If a random variable x follows poisson distribution such that $P(x=1)=2P(x=2)$, find the mean & the variance of the distribution	A	04	
	f)	One ticket is drawn at random from a bag containing 20 tickets numbered from 1 to 20. Find the probability that the number of tickets drawn is either even or square of an integer.	A	03	

P.T.O.

1/3

Q.3	Attempt any FOUR			(16)
a)	Prove that : $(1+\cos\theta+i.\sin\theta)^n+(1+\cos\theta-i.\sin\theta)^n$ $=2^{n+1}.\cos^n\left(\frac{\theta}{2}\right).\cos\left(\frac{n\theta}{2}\right)$	A	01	
b)	Convert into polar form, $z=1+i\sqrt{3}$	A	01	
c)	Find the length of perpendicular on the line $3x+4y-5=0$ from $(3,4)$	U	02	
d)	An insurance company found that only 0.01% of the population is involved in a certain type of accident each year. If its 1000 policy holders were randomly selected from the population, what is the probability that no more than two of its clients are involved in such accident next year?	A	04	
e)	Weights of 4000 students are found to be normally distributed with mean 50 kg & standard deviation 5kg. Find the number of students with weights i) Less than 45 kg ii) Between 45 & 60 kg (for a standard normal variate z, area under the curve between $z=0$ & $z=1$ is 0.3413 & between $z=0$ & $z=2$ is 0.4772)	A	03	
f)	If A & B are two events defined on a sample space such that $P(A\cup B)=5/6$, $P(A\cap B)=1/3$, $P(B)=\frac{1}{3}$, find $P(A)$	A	03	

2/3

QN	S Q N	Question Text	R/ U/ A	Co CCG 118	M ar ks
Q.4		Attempt any FOUR :			08
	a)	Show that $f(x) = 4x^4 + 3\cos x + x\sin x + 1$ is an even function.	R	4	
	b)	Evaluate $\lim_{x \rightarrow 2} \left[\frac{x-2}{x^2+x-6} \right]$.	R	4	
	c)	Find $\frac{dy}{dx}$, if $y = a^x \cdot x^a$.	R	5	
	d)	Evaluate $\lim_{x \rightarrow 1} \left[\frac{2}{x^2-1} - \frac{1}{x-1} \right]$.	U	4	
	e)	Differentiate with respect to x : $y = a^x + e^x + \log_{10} x + \log_{10} 10$	R	5	
	f)	Find $\frac{dy}{dx}$, if $y = \frac{\sin x}{1 + \cos x}$.	U	5	
Q.5		Attempt any FOUR :			16
	a)	If $f(x) = x^2 - 3x + 4$ then find x for which $f(1-x) = f(2x+1)$.	A	4	
	b)	If $y = \tan^{-1} \left(\frac{5x}{1-6x^2} \right)$ then find $\frac{dy}{dx}$.	U	5	
	c)	Evaluate $\lim_{x \rightarrow \infty} \left[\sqrt{x^2+x+1} - x \right]$	A	4	
	d)	If $e^x + e^y = e^{x+y}$ then find $\frac{dy}{dx}$.	A	5	
	e)	Find the equation of tangent and normal to the curve $y = x(2-x)$ at the point (2,0).	A	5	
	f)	If $y = \frac{e^x - e^{-x}}{e^x + e^{-x}}$ then show that $\frac{dy}{dx} = 1 - y^2$.	U	5	
Q.6		Attempt any FOUR :			16
	a)	If $f(x) = \log \left(\frac{1+x}{1-x} \right)$, then show that, $f(a) + f(b) = f \left(\frac{a+b}{1+ab} \right)$.	A	4	
	b)	If $y = x \log y$, then show that $\frac{dy}{dx} = \frac{y^2}{x(y-x)}$	U	5	
	c)	Evaluate $\lim_{x \rightarrow 2} \left[\frac{1}{x-2} + \frac{6x}{8-x^3} \right]$.	U	4	
	d)	If $x = a(\theta + \sin \theta)$, $y = a(1 + \cos \theta)$ then find $\frac{dy}{dx}$ at $\theta = \frac{\pi}{2}$.	A	5	
	e)	Find the maximum and minimum valuation of $y = x^3 - 18x^2 + 96x$.	A	5	
	f)	If $y = e^{\tan^{-1} x}$ then prove that $(1+x^2) \frac{d^2y}{dx^2} + (2x-1) \frac{dy}{dx} = 0$.	A	5	

GOVERNMENT POLYTECHNIC, KOLHAPUR 416004.
(An Autonomous Institute of Govt. of Maharashtra)
EVEN TERM END EXAM SUMMER -2023

EXAM SEAT NO.

--	--	--	--	--	--

LEVEL: **FIRST**

PROGRAM: **EE/IT/IE/ENTC**

COURSE CODE: **CCG118/CCF106**

COURSE NAME: **ENGINEERING MATHEMATICS**

MAX. MARKS: **80**

TIME: **3 HRS.**

DATE: **01/06/2023**

Instruction:-

- 1) Answer must be written in main answer book provided. (and supplements if required)
- 2) Illustrate your answers with sketches where ever necessary.
- 3) Use of non-programmable pocket calculator is permissible.
- 4) Mathematical and other tables will be made available on request.
- 5) Assume and mention suitable additional data necessary.
- 6) Use of Mobile is strictly prohibited.
- 7) QN-Question No, SQN-Sub-Question No, R- Remembering, U-Understanding, A-Application CO-Course outcome

QN	S Q N	QUESTION TEXT	RU A	CO CCG 118	Marks
Q.1	A	Attempt any FOUR			(08)
	a)	If $Z = 2+3i$, find $(Z+3)^2$	R	01	
	b)	Express the following as $x+iy$: $\frac{2+i}{(1-i)(3+i)}$	R	01	
	c)	Find equation of straight line passing through $(-1,6)$ and having slope $\frac{5}{6}$.	U	02	
	d)	Find the slope and intercepts of $\frac{x}{2} + \frac{y}{3} + \frac{1}{4} = 0$	R	02	
	e)	Show that the root of the equation $e^{-x} - x = 0$ lies between 0 and 1.	U	03	
	f)	Show that one of the roots of the equation $x^3 - x - 4 = 0$ lies between 0 and 2.	U	03	
Q.2	A	Attempt any FOUR			(16)
	a)	If $(3+i)x + (1-i)y = 1+7i$, find x & y .	A	01	
	b)	Find equation of straight line passing through $(5,6)$ and making equal intercepts on co-ordinate axes.	A	02	
	c)	Find the acute angle between the following pair of lines: $3x-2y+4=0$; $2x-3y-7=0$	U	02	
	d)	Find the approximate root of the equation $x^3 - x - 4 = 0$ using bisection method (carry out 3 iterations).	A	03	
	e)	By performing 3 iterations, find approximate root of $2x^3 - 3x + 4 = 0$ using Regula Falsi method.	A	03	
	f)	Solve the following equations using Jacobi's method (3 iterations only) $4x+y+3z=17$ $x+5y+z=14$ $2x-y+8z=12$	A	03	

Q.3	Attempt any FOUR			(16)
a)	Simplify the following using De Moivre's theorem:			
	$\frac{(\cos 3\theta + i \sin 3\theta)^4 (\cos 5\theta - i \sin 5\theta)^{4/5}}{\left(\cos \frac{9}{2}\theta + i \sin \frac{9}{2}\theta\right)^{2/3} \left(\cos \frac{4}{5}\theta + i \sin \frac{4}{5}\theta\right)^{10}}$	A	01	
b)	Convert the following in polar form : $z = -2 - 2\sqrt{3}i$	A	01	
c)	Find ;the perpendicular distance between the parallel lines $5x - 12y + 1 = 0$; $10x = 24y + 7$.	U	02	
d)	Using Refula Falsi method, find approximate root of $x^3 + 2x^2 - 8 = 0$ (carry out 3 iterations.)	A	03	
e)	Solve by Jacobi's method (only 3 iterations).			
	$\begin{aligned} 4x + y + 3z &= 17 \\ X + 5y + z &= 14 \\ 2x - y + 8z &= 12 \end{aligned}$	A	03	
f)	Solve the following system of equations by Gauss Seidel method. (carry out 3 iterations only)			
	$\begin{aligned} 20x + y - 2z &= 17 \\ 3x + 20y - z &= -18 \\ 2x - 3y + 20z &= 25 \end{aligned}$	A	03	

QN	S Q N	Question Text	R/ U/ A	Co CCG 118	M ar ks
Q.4		Attempt any FOUR :			08
	a)	Show that $f(x) = 4x^4 + 3 \cos x + x \sin x + 1$ is an even function.	R	4	
	b)	Evaluate $\lim_{x \rightarrow 2} \left[\frac{x-2}{x^2+x-6} \right]$.	R	4	
	c)	Find $\frac{dy}{dx}$, if $y = a^x \cdot x^a$.	R	5	
	d)	Evaluate $\lim_{x \rightarrow 1} \left[\frac{2}{x^2-1} - \frac{1}{x-1} \right]$.	U	4	
	e)	Differentiate with respect to x : $y = a^x + e^x + \log_{10} x + \log_{10} 10$	R	5	
	f)	Find $\frac{dy}{dx}$, if $y = \frac{\sin x}{1 + \cos x}$.	U	5	
Q.5		Attempt any FOUR :			16
	a)	If $f(x) = x^2 - 3x + 4$ then find x for which $f(1-x) = f(2x+1)$.	A	4	
	b)	If $y = \tan^{-1} \left(\frac{5x}{1-6x^2} \right)$ then find $\frac{dy}{dx}$.	U	5	
	c)	Evaluate $\lim_{x \rightarrow \infty} \left[\sqrt{x^2+x+1} - x \right]$	A	4	
	d)	If $e^x + e^y = e^{x+y}$ then find $\frac{dy}{dx}$.	A	5	
	e)	Find the equation of tangent and normal to the curve $y = x(2-x)$ at the point (2,0).	A	5	
	f)	If $y = \frac{e^x - e^{-x}}{e^x + e^{-x}}$ then show that $\frac{dy}{dx} = 1 - y^2$.	U	5	
Q.6		Attempt any FOUR :			16
	a)	If $f(x) = \log \left(\frac{1+x}{1-x} \right)$, then show that, $f(a) + f(b) = f \left(\frac{a+b}{1+ab} \right)$.	A	4	
	b)	If $y = x \log y$, then show that $\frac{dy}{dx} = \frac{y^2}{x(y-x)}$	U	5	
	c)	Evaluate $\lim_{x \rightarrow 2} \left[\frac{1}{x-2} + \frac{6x}{8-x^3} \right]$.	U	4	
	d)	If $x = a(\theta + \sin \theta)$, $y = a(1 + \cos \theta)$ then find $\frac{dy}{dx}$ at $\theta = \frac{\pi}{2}$.	A	5	
	e)	Find the maximum and minimum valuation of $y = x^3 - 18x^2 + 96x$.	A	5	
	f)	If $y = e^{\tan^{-1} x}$ then prove that $(1+x^2) \frac{d^2y}{dx^2} + (2x-1) \frac{dy}{dx} = 0$.	A	5	

GOVERNMENT POLYTECHNIC, KOLHAPUR – 416004.

(An Autonomous Institute of Govt. Of Maharashtra)

~~WINTER~~/SUMMER- 2023

EXAM SEAT NO.

--	--	--	--	--	--

LEVEL :- 1

PROGRAM : EEG/IEG/ETG/ITG

COURSE CODE :-CCG104/CCF 103

COURSE NAME :-ENGINEERING CHEMISTRY

MAX. MARKS : 80

TIME : 03 Hrs

DATE :- 30/05/2023

Instruction :-

- 1) Answers of two sections must be written in separate section answer book provided.
- 2) Illustrate your answers with sketches wherever necessary.
- 3) Use of non-programmable pocket calculator is permissible.
- 4) Mathematical and other tables shall be made available on request.
- 5) Assume and mention suitable additional data if necessary.
- 6) Use of Mobile is strictly prohibited.
- 7) QN- Question No., SQN-Sub Question No. R- Remembering, U- Understanding, A- Application.

QN	S Q N	Section I	R/ U/ A	CO	Mar ks
Q.1		Attempt any FOUR :			08
	a	Define Electrolyte and Electrolysis.	R	CCG104-1	
	b	Define adhesives.	R	CCG104-3	
	c	Enlist fundamental particles of atom with their charges.	R	CCG104-1	
	d	Define catalyst.	R	CCG104-3	
	e	Define corrosion with its types.	R	CCG104-2	
	f	Distinguish between isotopes and isobars(Any two points).	R	CCG104-1	
Q.2		Attempt any FOUR :			16
	a	List any four characteristics of good insulator.	R	CCG104-3	
	b	Explain electrolysis of molten sodium chloride(NaCl) with reactions.	A	CCG104-1	
	c	State Hund's rule and Aufbau's principle.	R	CCG104-1	
	d	Explain types of catalyst with examples.	U	CCG104-3	
	e	Discuss factors influencing immersed corrosion.	U	CCG104-2	
	f	Differentiate thermo softening plastic from thermosetting plastic.	U	CCG104-3	
Q.3		Attempt any FOUR :			16
	a	Explain formation of water molecule (H ₂ O).	U	CCG104-1	
	b	Give properties and applications of composite materials.	A	CCG104-3	
	c	Explain vulcanization of rubber with chemical reaction.	A	CCG104-3	
	d	Explain the process of galvanizing with their advantages.	A	CCG104-2	
	e	Explain properties and applications of plastics.	U	CCG104-3	
	f	Explain electro refining of blister copper.	A	CCG104-1	

P.T.O.

QN	S Q N	QUESTION TEXT	R U A	CO CCG104	Marks
Q.4		Attempt any FOUR			(08)
	a)	Explain two disadvantages of hard water in sugar industry.	U	4	
	b)	Define Battery, separator.	R	1	
	c)	Classify Batteries with example.	R	1	
	d)	Distinguish between mineral & ore. (Any two Points)	U	5	
	e)	Enlist two properties of copper.	U	5	
	f)	Define alloy. Classify alloy.	R	6	
Q.5		Attempt any FOUR			(16)
	a)	Explain sterilization of water with Cl ₂ .	A	4	
	b)	Distinguish between Hard water & Soft water. (Any Four Points)	U	4	
	c)	Explain construction & working of lead Acid storage Battery while discharging.	A	1	
	d)	Explain froth flotation method with diagram.	U	5	
	e)	Explain Bessemerisation process with diagram.	A	5	
	f)	Explain four purposes of making alloy.	U	6	
Q.6		Attempt any FOUR			(16)
	a)	Explain four reactions of Hard water with soap.	U	4	
	b)	Explain impurities in Natural water.	U	4	
	c)	Define – E.M.F., Electrochemical cell charge, open circuit voltage.	R	1	
	d)	Explain with diagram solar cell.	U	1	
	e)	Explain with reactions Roasting process.	U	5	
	f)	Enlist steps involved in Flow chart of concentration of ores.	U	5	

GOVERNMENT POLYTECHNIC, KOLHAPUR – 416004.

(An Autonomous Institute of Govt. Of Maharashtra)

EVEN TERM END EXAM SUMMER -2023**EXAM SEAT NO.**

--	--	--	--	--	--

LEVEL :- **FIRST**PROGRAM : **CE/ME/MT**COURSE CODE :- **CCG103/CCF103/0105**COURSE NAME **ENGINEERING CHEMISTRY**MAX. MARKS : **80** TIME : **03Hrs.**DATE :- **30/05/2023**

Instruction :-

- 1) Answers must be written in the main answer book provided.(and supplements if required)
- 2) Illustrate your answers with sketches wherever necessary.
- 3) Use of non-programmable pocket calculator is permissible.
- 4) Mathematical and other tables shall be made available on request.
- 5) Assume and mention suitable additional data if necessary.
- 6) Use of Mobile is strictly prohibited.
- 7) QN- Question No., SQN-Sub Question No. R- Remembering, U- Understanding, A- Application.

QN	S Q N	Question Text	R/ U/ A	Co CCG 103	Mar ks
Q.1		Attempt any FOUR :			08
	a)	Define Atomic number and Atomic mass number.	R	1	
	b)	Define Positive catalyst and Negative catalyst.	R	3	
	c)	State Electrodes. Explain Anode and Cathode.	U	1	
	d)	Give Drawbacks of Natural rubber.	U	3	
	e)	State Pauli's exclusive principle.	U	1	
	f)	State various types of oxide films formed in Atmospheric corrosion.	U	2	
Q.2		Attempt any FOUR :			16
	a)	Describe preparation of thermocole. Give two properties and two uses of Thermocole.	R	3	
	b)	Define Electrovalency. Explain the formation of NaCl molecule on the basis of Electrovalency.	U	1	
	c)	Explain which Electrochemical process is used for purification of Impure metal.	A	1	
	d)	Describe the process of Metal spraying with neat labelled diagram.	U	2	
	e)	Define Polymerization. Distinguish between Addition and condensation polymerization.	U	3	
	f)	Define catalyst. Explain catalytic promoters and catalytic inhibitors with example.	R	3	
Q.3		Attempt any FOUR :			16
	a)	Explain Vulcanization of Rubber. Give any two engineering properties and uses of Rubber.	U	3	
	b)	Give engineering properties and applications of plastics.	R	3	
	c)	Give Bohr's theory of atom.	R	1	
	d)	Define degree of Ionisation. Explain factors affecting degree of Ionisation.	U	1	
	e)	Describe the process of tinning with neat labelled diagram.	U	2	
	f)	Define composite materials. Give classification of composite materials with example.	U	3	

P.T.O

QN	S Q N	Question Text	R/ U/ A	Co CCG 103	M ar ks
Q.4		Attempt any FOUR :			08
	a)	Define soft water.	R	4	
	b)	State any two disadvantages of Chlorination method used for sterilization of water.	R	4	
	c)	Name any two salts which causes permanent hardness in water.	R	4	
	d)	Define alloy.	R	3	
	e)	Define i) Concentration of ore ii) Flux.	R	5	
	f)	Write any two functions of fillers used in oil paint.	A	2	
Q.5		Attempt any FOUR :			16
	a)	Define hard water. Write the reaction of hard water with Soap.	U	4	
	b)	State the impurities present in water with one example of each type of impurity.	R	4	
	c)	Write any four differences between Calcination and Roasting.	U	5	
	d)	Write any four purposes of making an alloy.	A	3	
	e)	Explain fluid film Lubrication.	U	6	
	f)	Define paint and varnish. State two types of varnishes.	R	2	
Q.6		Attempt any FOUR :			16
	a)	Write disadvantages of hard water when used for i) Textile industry. ii) Sugar industry.	A	4	
	b)	Explain electromagnetic separation method.	U	5	
	c)	State the composition of i) Duralumin ii) Wood's metal.	R	3	
	d)	Write any four characteristics of a good lubricant.	R	6	
	e)	Explain viscosity and viscosity index in lubricants.	U	6	
	f)	Write any four characteristics of a good paint.	R	2	

GOVERNMENT POLYTECHNIC, KOLHAPUR 416004.

(An Autonomous Institute of Govt. of Maharashtra)

EVEN TERM END EXAM SUMMER -2023

EXAM SEAT NO.

--	--	--	--	--	--	--	--

LEVEL: **FIRST**

PROGRAM: **EE/IE/ET/IT**

COURSE CODE: **CCG 102 /CCF 102**

COURSE NAME: **Engineering Physics**

MAX. MARKS: **80**

TIME: **3 HRS.**

DATE: **29/05 /2023**

Instruction :-

- 1) Answer must be written in main answer book provided. (and supplements if required)
- 2) Illustrate your answers with sketches where ever necessary.
- 3) Use of non-programmable pocket calculator is permissible.
- 4) Mathematical and other tables will be made available on request.
- 5) Assume and mention suitable additional data necessary.
- 6) Use of Mobile is strictly prohibited.
- 7) QN-Question No, SQN-Sub-Question No, R- Remembering, U-Understanding, A-Application CO-Course outcome

QN	S Q N	QUESTION TEXT	R U A	CO CEG 102	Mark s
Q.1		Attempt any FOUR			(08)
	a)	State Stoke's law of viscosity.	R	2	
	b)	Define significant figure.	R	1	
	c)	Define the terms i) Elastic limit ii) Breaking stress	R	2	
	d)	Define terminal velocity. Give its unit.	R	2	
	e)	Distinguish between fundamental & derived quantities (any 2 points)	U	1	
	f)	State any two characteristics of SHM.	U	3	
Q.2		Attempt any FOUR			(16)
	a)	Define the terms i) Unit ii) Error iii) Instrumental error iv) Random error	R	1	
	b)	State any four applications of viscosity.	A	2	
	c)	Distinguish between longitudinal & transverse wave.(Any 4 points)	U	3	
	d)	State the fundamental quantities in SI with their units.	U	4	
	e)	Define the terms i) Amplitude ii) Periodic time ii) Frequency iv) Wavelength	R	3	
	f)	A weight exerts force of 100N on a steel wire of cross sectional area 0.02 cm ² . Find extension produced if the length of wire is 5m ($Y=2 \times 10^{11}$ N/m ²)	A	2	
Q.3		Attempt any FOUR			(16)
	a)	State any four applications of elasticity.	R	2	
	b)	Derive expression for coefficient of viscosity by Stoke's method.	A	2	
	c)	Define the term i) Free oscillations ii) Forced oscillations ii) Periodic motion iv) Linear S.H.M.	R	3	
	d)	State & Explain the terms i) Young's modulus ii) Bulk modulus	U	2	
	e)	State any four applications of resonance .	A	3	
	f)	The mass of an object is 54.22 ± 0.01 kg. Find the percentage error.	A	4	

P.T.O.

QN	S Q N	QUESTION TEXT	RU A	CO CCG 102	Marks
Q.4		Attempt any FOUR			(08)
	a)	State the physical conditions on which resistance of a conductor depends.	R	04	
	b)	Define :- i) Optical pumping ii) Population inversion.	R	05	
	c)	Define :- i) Nanometer ii) Nano technology.	R	05	
	d)	Explain how intensity of X-rays can be controlled.	U	05	
	e)	State the conditions for TIR to take place.	R	06	
	f)	Draw a neat labeled diagram showing structure of optical fibre.	R	06	
Q.5		Attempt any FOUR			(16)
	a)	With the help of a neat diagram obtain the balanced condition of a wheatstones network.	A	04	
	b)	For a prism show that $\mu = \frac{\sin\left(\frac{A + \delta m}{2}\right)}{\sin\left(\frac{A}{2}\right)}$	A	04	
	c)	Explain working principle of laser	U	05	
	d)	State applications of nanotechnology in the field of i) Environment ii) cosmetics (two each)	A	05	
	e)	The R.I. of a prism for Red, Yellow and Violet colours are 1.48, 1.50 and 1.52 respectively. Find the dispersive power of the prism.	A	04	
	f)	Calculate specific resistance of a wire 6m in length, 0.4mm in diameter and having a resistance of 30Ω.	A	04	
Q.6		Attempt any FOUR			(16)
	a)	Define i) Angular dispersion ii) Refraction iii) Angle of deviation iv) dispersion power.	R	04	
	b)	Explain stimulated emission of light with the help of a neat diagram.	U	05	
	c)	State any four properties of X-rays.	A	05	
	d)	With the help of a neat diagram explain the propagation of light in an optical fibre.	U	06	
	e)	Three resistances of 1 Ω, 2 Ω and 3 Ω are connected in series and then in parallel. Find the effective resistance in each case.	A	04	
	f)	State any four advantages of optical fibres over conventional metal conductors.	U	06	

GOVERNMENT POLYTECHNIC, KOLHAPUR 416004.
(An Autonomous Institute of Govt. of Maharashtra)
EVEN TERM END EXAM SUMMER -2023

EXAM SEAT NO.

--	--	--	--	--	--

LEVEL: **FIRST**

PROGRAM: **CE/ME/MT**

COURSE CODE: **CCG101/CCF101**

COURSE NAME: **Engineering Physics**

MAX. MARKS: **80**

TIME: **3 HRS.**

DATE: **29/05/2023**

Instruction:-

- 1) Answer must be written in main answer book provided. (and supplements if required)
- 2) Illustrate your answers with sketches where ever necessary.
- 3) Use of non-programmable pocket calculator is permissible.
- 4) Mathematical and other tables will be made available on request.
- 5) Assume and mention suitable additional data necessary.
- 6) Use of Mobile is strictly prohibited.
- 7) QN-Question No, SQN-Sub-Question No, R- Remembering, U-Understanding, A-Application CO-Course outcome

QN	S Q N	QUESTION TEXT	RU A	CO CCG 101	Marks
Q.1	A	Attempt any FOUR			(08)
	a)	Define unit and state S1 unit of force.	R	01	
	b)	Mention any two properties of SHM.	U	03	
	c)	State any two requirements of good unit.	R	01	
	d)	Define velocity gradient. State its SI unit.	R	02	
	e)	State any two applications of viscosity.	A	02	
	f)	State and explain Stoke's law.	R	02	
Q.2	A	Attempt any FOUR			(16)
	a)	A student measures diameter of bob three times using vernier caliper. The measurements are 0.62cm. 0.65cm and 0.63cm. Estimate percentage error in the measurement.	A	01	
	b)	Distinguish between elastic body and plastic body (any four points)	U	02	
	c)	State and explain Newton's law of viscosity Hence define coefficient of viscosity and state its unit.	U	02	
	d)	State any four characteristics of SHM.	R	03	
	e)	Explain types of system of units.	U	01	
	f)	Explain forced and free oscillations with one example of each.	U	03	
Q.3		Attempt any TWO			(16)
	a)	State and explain two types of error in measurement.	U	01	
	b)	A wire of length 3m and radius 0.0005m extends by 0.003m after applying a force of 150N. Calculate Youngs modulus of material of wire.	A	02	
	c)	Derive an expression for coefficient of viscosity by Stoke's method.	A	02	
	d)	Define : i) Deforming force ii) Restoring force iii) Stress iv) Strain	R	02	
	e)	Differentiate between transverse wave and longitudinal wave (any four points)	U	03	
	f)	Explain why soldiers are asked to break their steps while crossing a bridge.	A	03	

Q.4	Attempt any FOUR			(08)
	a) Write Sabine's formula & meanings of each symbol.	U	06	
	b) State the factors on which resistance of a conductor depends.	R	04	
	c) Define nanometer & nanoparticle.	R	05	
	d) Give any two applications of X-rays.	U	05	
	e) State Ohm's law. Give unit of resistance.	R	04	
	f) Give any two applications of ultrasonic waves.	U	06	
Q.5	Attempt any FOUR			(16)
	a) State & explain properties of laser.	U	05	
	b) Derive an expression for the effective resistance when the resistances are connected in series.	A	04	
	c) Define the terms :- i) Dispersion ii) Angular dispersion iii) Dispersive power iv) Refraction.	R	04	
	d) State any four applications of nanotechnology.	A	05	
	e) Explain magnetostriction method for production of ultrasonic waves.	U	06	
	f) For an equilateral prism, the angle of minimum deviation is 30° . Find the refractive index of prism.	A	04	
Q.6	Attempt any FOUR			(16)
	a) Describe how X-rays are produced by using Coolidge tube.	U	05	
	b) Derive prism formula for refractive index.	A	04	
	c) Explain population inversion, with the help of neat diagrams.	U	05	
	d) State & prove parallel law of resistances.	A	04	
	e) Mention any four requirements of an auditorium.	R	06	
	f) Calculate the specific resistance of wire 6m in length, 0.5mm in diameter & having resistance of 32 Ohm.	A	04	

GOVERNMENT POLYTECHNIC, KOLHAPUR 416004.
(An Autonomous Institute of Govt. of Maharashtra)
EVEN TERM END EXAM SUMMER -2023

EXAM SEAT NO.

--	--	--	--	--	--

LEVEL: **FIRST**

PROGRAM: **COMMON**

COURSE CODE: **CCG107/CCF107**

COURSE NAME: **Engineering Drawing I**

MAX. MARKS: **80**

TIME: **4 HRS.**

DATE: **25/05/2023**

Instruction :-

- 1) Answer must be written in main answer book provided. (and supplements if required)
- 2) Illustrate your answers with sketches where ever necessary.
- 3) Use of non-programmable pocket calculator is permissible.
- 4) Mathematical and other tables will be made available on request.
- 5) Assume and mention suitable additional data necessary.
- 6) Use of Mobile is strictly prohibited.
- 7) QN-Question No, SQN-Sub-Question No, R- Remembering, U-Understanding, A-Application CO-Course outcome

QN	S Q N	QUESTION TEXT	RU A	CO CCG107	Marks
Q.1	A	Attempt any TWO			(04)
	a)	List any four drawing instruments.	R	1	
	b)	Construct a pentagon of Base side 25mm.	A/ U	1	
	c)	Draw Convention of following line with application i) Cutting plane line ii) Hidden line	R	1	
	B	Attempt any ONE			(04)
	a)	Construct a plane scale with R.F. 1:40 to read upto 5 meters in meters and decimeters.	U/ A	1	
	b)	Construct a diagonal scale of R.F. 1:50 to read meters, decimeters and centimeters to measure upto 5 meters show the length 2 meters, 6 decimeters and 5 centimeters on the scale.	U/ A	1	
Q.2	A	Attempt any TWO			(12)
	a)	Draw an involute & pentagon of base side 20mm.	U/ A	2	
	b)	The distance between the fixed straight line and a fixed point is 80mm. Draw a hyperbola if eccentricity is 5/3.	U/ A		
	c)	Two fixed point F_1 and F_2 are 100mm apart draw the path traced out by a point P, moving in the same plane such that the sum of its distances from F_1 and F_2 is always same and is equal to 125 mm. Name the curve.	U/ A	2	
	B	Attempt any TWO			(08)
	a)	Construct a rectangle parabola with base length 80mm. and axis height 60mm.	U/ A	2	
	b)	Draw a cycloid of circle of 40mm diameter.	U/ A	2	
	c)	Construct an ellipse when its major axis is 120mm and minor axis 80mm by using concentric circle method.	U/ A	2	

P-1/3

P.T.O.

Q.3	Attempt any THREE			(12)
	a) A line AB, 70mm long has its end A 25mm above the H.P. and 30mm in front of V.P. draw its projections when it is parallel to V.P. and inclined at 30° to H.P.	U/ A	3	
	b) The distance between the projectors through the ends of a line MN, 75mm long is 60mm its end M is 15mm above the H.P. and 20mm in front of V.P. draw the projection of line when it is parallel to V.P. determine the inclination with H.P.	U/ A	3	
	c) The front view of a line PQ 100mm long measures 85mm. The end P is 20mm above H.P. and 40mm in front of V.P. draw the projections if its parallel to H.P. find its inclination with V.P.	U/ A	3	
	d) A line CD, 75mm long is parallel to V.P. and 25mm from it. Its end C and D are 10mm and 40mm above H.P. respectively. Draw its projections and find its inclination with H.P.	U/ A	3	
Q.4	Attempt any TWO			(08)
	a) A rectangular plate of size 60x40mm, is perpendicular to both the reference planes. Draw its projection. State the view which gives the true shape.	U/ A	4	
	b) Show the location of front view, top view and side view in relation to the reference line xy, for first angle projection method and third angle projection method. Draw the conventions of both methods.	U	5	
	c) Draw following types of sections and state their applications. i) Half Section. ii) Revolved Section.	R	5	
Q.5	Attempt any TWO			(16)
	a) A regular hexagon of 30mm side has its one edge in VP. The surface is perpendicular to the HP and inclined at 45° to VP. Draw three views of the plane.	U	4	
	b) A compass has its legs 60mm long. The angle between them is 30° . It is resting on HP on the ends of its legs with the line joining shoes ends perpendicular to VP and head 35mm above HP. Draw its three views. Determine the angle made by the plane of compass with HP.	U/ A	4	
	c) Figure no. 1 shows pictorial view of an object. Draw its front view in the direction of X. Show all the dimension in it.	A	5	
Q.6	Attempt any TWO			(16)
	a) Figure no. 2 shows pictorial view of an object. Draw its following views, by first angle method of projection. i) Front view in the direction of X ii) Top view.	U/ A	5	
	b) Figure no. 3 shows pictorial view of an object. Draw its sectional front view in the direction of X, taking section along AA. Show all dimension in it.	U/ A		
	c) Figure no. 4 shows pictorial view of an object draw its following view by first angle method of projection. i) Sectional front view in the direction of X, taking section along SS. ii) Top View.	U/ A	5	

Q.No.5.(C)

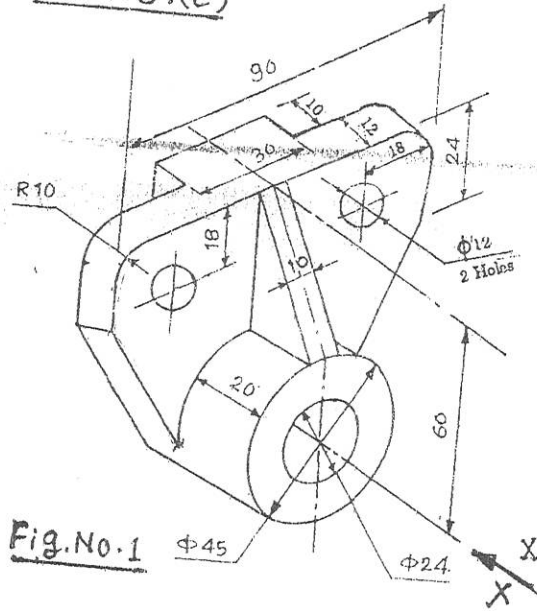

Fig.No.1

Q.No.6(a)

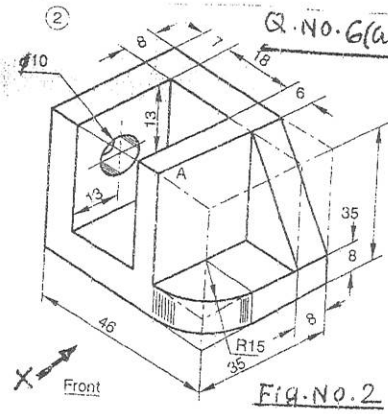

Fig.No.2

Q.No.6(b)

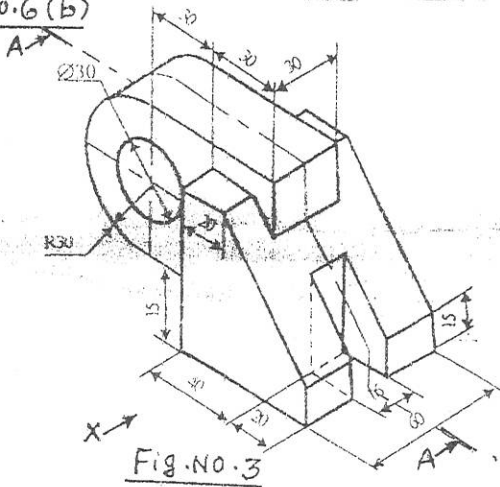

Fig.No.3

Q.No.6(c)

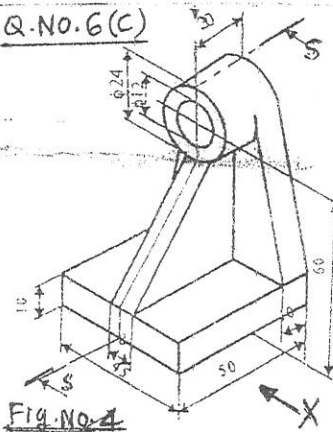

Fig.No.4

