

GOVERNMENT POLYTECHNIC, KOLHAPUR – 416004.

(An Autonomous Institute of Govt. Of Maharashtra)

SUMMER-2024

EXAM SEAT NO.

LEVEL : -FIFTH

PROGRAM : CIVIL ENGINEERING

COURSE CODE :- CEG 503

COURSE NAME :- Construction Management

MAX. MARKS : 80 TIME : 03 Hrs

DATE :- 22/5/2024

Instruction :-

- 1) Answers of two sections must be written in separate section answer book provided.
- 2) Illustrate your answers with sketches wherever necessary.
- 3) Use of non-programmable pocket calculator is permissible.
- 4) Mathematical and other tables shall be made available on request.
- 5) Assume and mention suitable additional data if necessary.
- 6) Use of Mobile is strictly prohibited.
- 7) QN- Question No., SQN-Sub Question No. R- Remembering, U- Understanding, A- Application.

QN	S Q N	SECTION - I	R/ U/ A	Co CEG 503	Ma rks
Q.1		Attempt any FOUR:			08
	a)	Enlist any four agencies associated with construction work.	R	1	
	b)	Define the term Bureaucratic leadership.	U	2	
	c)	Define management.	U	3	
	d)	Write any four desirable qualities of leader.	R	2	
	e)	Write the meaning of "pre tender planning".	R	1	
	f)	What is critical path?	A	3	
Q.2		Attempt any FOUR:			16
	a)	Name any four personnel required on construction site of multistoried buildings and state any two functions of them.	R	1	
	b)	Differentiate between CPM & PERT any four point.	A	3	
	c)	Explain in brief, the importance of planning in construction work.	U	2	
	d)	State the various types of organization and explain any one with advantages & disadvantages.	U	2	
	e)	Explain any four principles of management.	R	2	
	f)	Write any eight desirable qualities of leadership.	U	2	
Q.3		Attempt any FOUR:			16
	a)	Describe any four barriers in effective communication.	R	2	
	b)	Draw organization chart for PWD	A	2	
	c)	Explain any four functions of management.	U	2	
	d)	Define the term motivation. Explain its importance.	R	2	
	e)	Explain any four advantages of network tool over bar chart.	U	3	
	f)	Suggest the suitable type of organization for middle scale industry. Explain with a neat sketch	A	2	

P.T.O.

GOVERNMENT POLYTECHNIC, KOLHAPUR – 416004.

(An Autonomous Institute of Govt. Of Maharashtra)

SUMMER- 2024

EXAM SEAT NO.

--	--	--	--	--	--

LEVEL :- FIFTH

PROGRAM : CIVIL ENGINEERING

COURSE CODE :- CEG 503

COURSE NAME :- CONSTRUCTION MANAGEMENT

MAX. MARKS : 80 TIME : 03 Hrs DATE :-22/5/2024

QN	S Q N	SECTION -II	R/ U/ A	CEG 503	Ma rks
Q.4		Attempt any FOUR :			08
	a)	Give any two objectives of HR department.	U	04	
	b)	State any two provisions of minimum wages act.	R	04	
	c)	Define Economic Order Quantity.	R	05	
	d)	Give any two objectives of material management.	U	05	
	e)	Draw any two symbols used in process chart prepared in motion study.	A	06	
	f)	Enlist any four safety devices.	R	06	
Q.5		Attempt any FOUR :			16
	a)	State any four details recorded in personnel policy.	R	04	
	b)	Discuss the objectives of employee training.	U	04	
	c)	Explain ABC technique of material management.	U	05	
	d)	State duties of material manager.	R	05	
	e)	Describe the objectives of method study.	U	06	
	f)	Explain the importance of safety at construction site.	A	06	
Q.6		Attempt any FOUR :			16
	a)	Explain workers participation in management.	U	04	
	b)	Discuss the importance of workmen's compensation act.	U	04	
	c)	Explain in brief modern techniques used in material management.	A	05	
	d)	Give any four causes of accidents on construction site.	R	06	
	e)	Enlist various allowances used in work measurement.	R	06	
	f)	Explain the concept of productivity.	U	06	

GOVERNMENT POLYTECHNIC, KOLHAPUR – 416004.

(An Autonomous Institute of Govt. Of Maharashtra)

SUMMER-2024

EXAM SEAT NO.

--	--	--	--	--	--

LEVEL :- THIRD

PROGRAM : CIVIL ENGINEERING

COURSE CODE :- CEG303/CEF303

COURSE NAME :- Building Drawing

MAX. MARKS : 80 TIME : 04 Hrs

DATE :- 21/5/2024

Instruction :-

- 1) Answers must be written in main answer book provided.(And supplements if required)
- 2) Illustrate your answers with sketches wherever necessary.
- 3) Use of non-programmable pocket calculator is permissible.
- 4) Mathematical and other tables shall be made available on request.
- 5) Assume and mention suitable additional data if necessary.
- 6) Use of Mobile is strictly prohibited.
- 7) QN- Question No., SQN-Sub Question No. R- Remembering, U- Understanding, A- Application.

QN	S Q N	Question Text	R/ U/ A	CO	Mark s
Q.1		Attempt any FOUR :			(08)
	a)	State any four requirements good drawing.	R	CEG303-1	2
	b)	Draw the symbols for- i)Wood in cross section ii) Ground level	R	CEG303-1	2
	c)	Write the standard dimensions of – i) Window sill height in bathroom ii) Floor to ceiling height for garage	R	CEG303-3	2
	d)	State the minimum dimensions for-i) W.C. ii) Bath Room	R	CEG303-3	2
	e)	State the difference between one point perspective and two point perspective.		CEG303-5	2
	f)	Define the terms-i)picture plane ii) Vanishing point.		CEG303-5	2
Q.2		Attempt any FOUR :			(16)
	a)	Draw various types of lines as per IS 962:1989		CEG303-1	4
	b)	Enlist the various agencies require for building construction work and state the role of owner and architect.	U	CEG303-2	4
	c)	Enlist the various principles of planning of Residential building And write aspects of all residential units.	U	CEG303-3	4
	d)	Draw to suitable scale Line plan of- Post Office Building. Write the dimension of each room.	A	CEG303-4	4
	e)	Enlist the units required for Primary school building along with its minimum required sizes.	R	CEG303-4	4
	f)	Explain the necessity of perspective view and State the Principles of perspective drawing.		CEG303-5	4
Q.3		Attempt any TWO :			(16)
	a)	1)Define the terms- i)Built-up-area ii) Plinth area iii)Floor area iv) F.S.I.	U	CEG303-2	4
		2) Enlist the names of various plan sanctioning authorities and List out various documents required for plan sanctioning.	R	CEG303-2	4
	b)	Draw the line plan of 2BHK bungalow by assuming appropriate sizes of rooms applying principles of planning.	A	CEG303-3	8
	c)	Figure shows plan and side elevation of structure,draw to suitable sscale two point perspective drawing. Assume eye level at 1.5 m above G.L.The observer stands at distance of 3.2m along central visual ray. Retain all construction lines.	A	CEG303-5	8

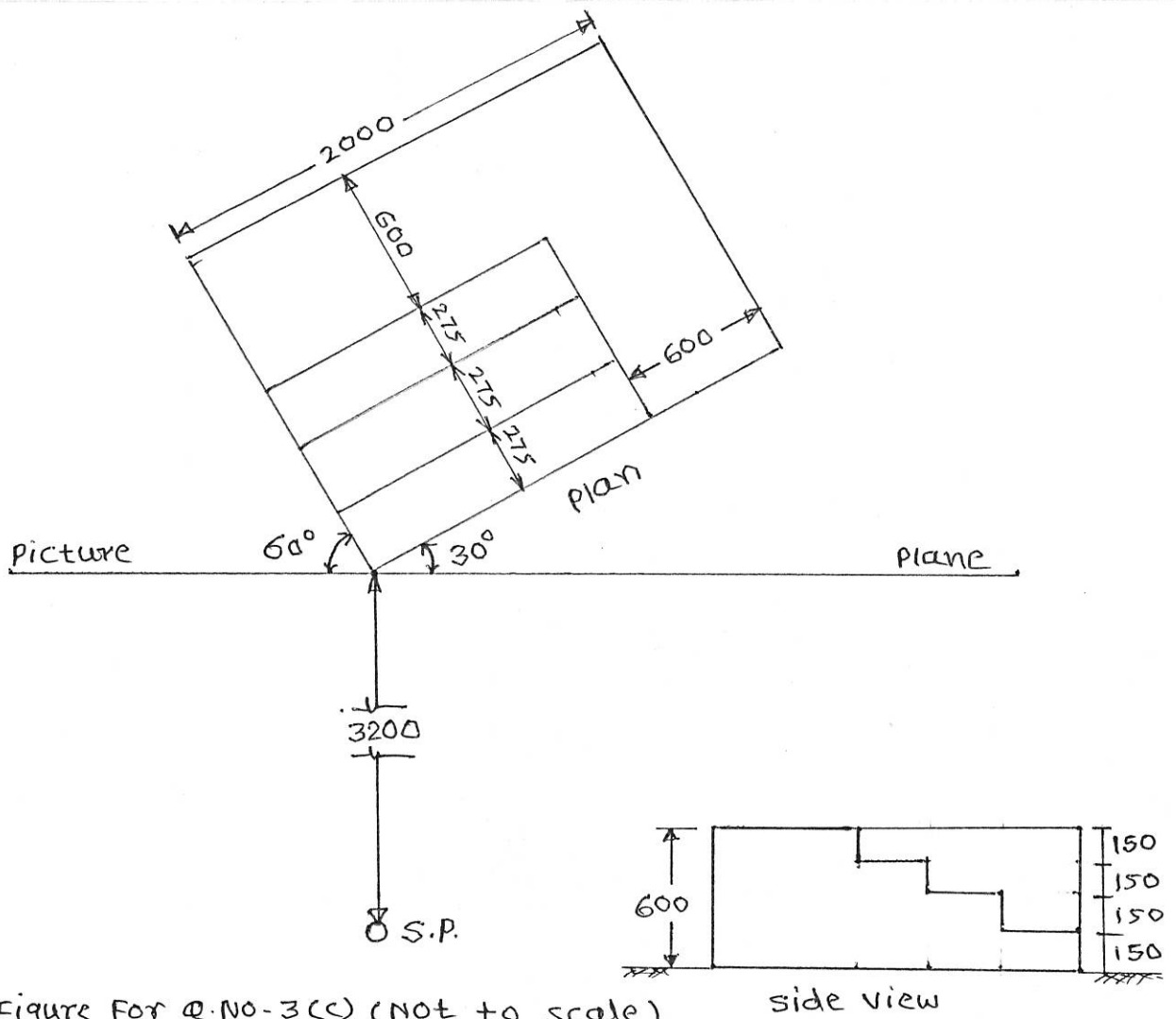

Figure For Q.No-3(c) (NOT to scale)
 Note - All dimensions are in mm.

GOVERNMENT POLYTECHNIC, KOLHAPUR – 416004.

(An Autonomous Institute of Govt. Of Maharashtra)

SUMMER- 2024**EXAM SEAT NO.**

--	--	--	--	--	--

LEVEL :- III

PROGRAM : CIVIL ENGINEERING

COURSE CODE :- CEG 303/CEF303

COURSE NAME :- BUILDING DRAWING

MAX. MARKS : 80 TIME : 04 Hrs DATE :- 2/5/2024

QN	S Q N	Question Text	R/ U/ A	Co CEG 303	Ma rks
Q.4		Attempt the following Question			40
		<p>Figure 'B' shows the line plan of small residential building. Draw to a scale of 1:50 the following views, using the given data</p> <p>a. Detailed developed plan. b. Front elevation c. Section X-Y d. Prepare schedule doors and windows e. Prepare Area statement f. Show the North Direction</p> <p>Use the following data-</p> <p>i. Hard Strata is available at a depth of 1200 mm below G.L. ii. Structure is single storey load bearing structure iii. At the base of foundation, Bed Concrete P.C.C. of 1:4:8 is provided of 150 mm thick and 900 mm wide iv. Foundation Masonry 600 mm height is provided in U.C.R. v. Plinth masonry of 450 mm width and 600 mm height above G.L. in U.C.R. vi. B.B. masonry 300 mm thick for main walls and 200 mm thick partition wall for W.C. and bath. vii. Ceiling height is 3000 mm from floor level. viii. R.C.C. slab 120 mm thick and projection is 150 mm from exterior face of the wall ix. Provide ^{suitable} type, size of doors and windows at suitable positions. x. Provide R.C.C. lintel and chajjas on masonry openings. xi. Provide kitchen platform, Sink, Wash Basin etc. at suitable positions xii. Assume suitable plot size xiii. Assume any other suitable data if necessary</p> <p>ReferFigure 'B'</p>	A A A A U U	6 6 6 6 6 6	10 08 12 05 04 01

P.T.D. 3/4

Q.4

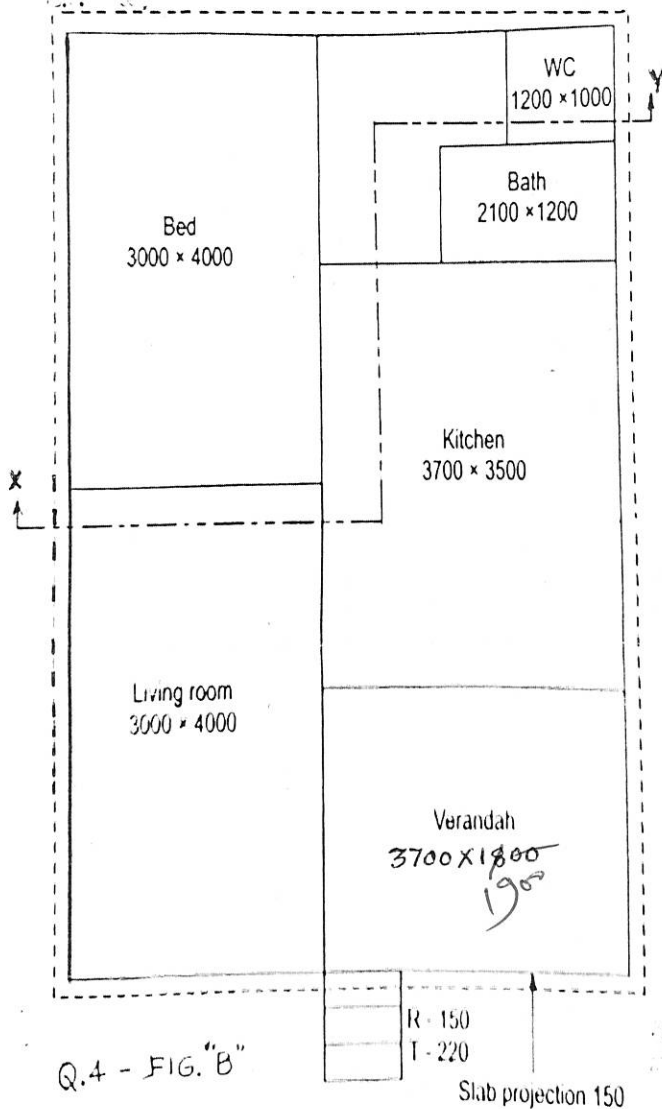

Q.4 - FIG. "B"

All dimensions are in mm

GOVERNMENT POLYTECHNIC, KOLHAPUR – 416004

(An Autonomous Institute of Govt. Of Maharashtra)

SUMMER 2024

EXAM SEAT NO.

--	--	--	--	--	--	--	--

LEVEL :- IV

PROGRAM : CIVIL ENGINEERING

COURSE CODE : CEG 405 / CEF406

COURSE NAME : CONCRETE TECHNOLOGY

MAX. MARKS : 80 TIME : 3 HRS. DATE :- 20/5/2024

Instructions :-

- 1) Answers of two sections must be written in separate section answer book provided.
- 2) Illustrate your answers with sketches wherever necessary.
- 3) Use of non-programmable pocket calculator is permissible.
- 4) Mathematical and other tables shall be made available on request.
- 5) Assume and mention suitable additional data if necessary.
- 6) Use of Mobile is strictly prohibited.
- 7) QN- Question No., SQN-Sub Question No. R- Remembering, U- Understanding, A- Application.

QN	S Q N	Section- I	R/ U/ A	CO	Marks																
Q.1		Attempt any FOUR :			08																
	a)	State role of each ingredient in concrete.	R	1																	
	b)	Draw process diagram of concrete.	R	1																	
	c)	Define fineness modulus of aggregate.	R	2																	
	d)	State any four types of cement	U	2																	
	e)	State any four properties of coarse aggregates.	R	2																	
	f)	Define segregation of concrete.	R	3																	
Q.2		Attempt any FOUR :			16																
	a)	State any four methods of curing. Explain any one method in detail.	R	1																	
	b)	Explain test procedure to determine standard consistency of cement with neat diagram.	U	2																	
	c)	Which type of cement is required for 1. Plastering and pointing works 2. Aesthetic joints 3. Coloured cement manufacture 4. Water retaining structures.	A	2																	
	d)	State any four precautions taken while storing the cement.	R	2																	
	e)	Define bleeding and state ant four precautions taken for freedom from bleeding	U	3																	
	f)	Explain slump cone test with neat diagrams.	U	3																	
Q.3		Attempt any FOUR :			16																
	a)	A 500 gm of air dry sample of fine aggregate is sieved through number of sieves and observations are recorded as: <table border="1" data-bbox="272 1988 1279 2143"><tr><td>IS SIEVE SIZE (mm)</td><td>10</td><td>4.75</td><td>2.36</td><td>1.18</td><td>0.600</td><td>0.300</td><td>0.150</td></tr><tr><td>Weight retained in gm</td><td>0</td><td>10</td><td>50</td><td>50</td><td>95</td><td>185</td><td>110</td></tr></table>	IS SIEVE SIZE (mm)	10	4.75	2.36	1.18	0.600	0.300	0.150	Weight retained in gm	0	10	50	50	95	185	110	A	2	
IS SIEVE SIZE (mm)	10	4.75	2.36	1.18	0.600	0.300	0.150														
Weight retained in gm	0	10	50	50	95	185	110														
	b)	Explain in brief heat of hydration of cement.	U	2																	
	c)	State and explain factors affecting workability of concrete.	R	3																	
	d)	Define admixture. State any four types of admixtures.	R	1																	
	e)	State precautions taken while placing the concrete.	R	1																	
	f)	State modes of transportation of concrete and explain any one mode in detail.	R	1																	

GOVERNMENT POLYTECHNIC, KOLHAPUR – 416004

(An Autonomous Institute of Govt. Of Maharashtra)

SUMMER 2024

EXAM SEAT NO.

--	--	--	--	--	--

LEVEL : - FORU~~TH~~

PROGRAM : CIVIL ENGINEERING

COURSE CODE : CEG 405/CEF406

COURSE NAME : CONCRETE TECHNOLOGY

MAX. MARKS : 80 TIME : 3 HRS.

DATE :- 20/5/2024

Instruction :-

- 1) Answers of two sections must be written in separate section answer book provided.
- 2) Illustrate your answers with sketches wherever necessary.
- 3) Use of non-programmable pocket calculator is permissible.
- 4) Mathematical and other tables shall be made available on request.
- 5) Assume and mention suitable additional data if necessary.
- 6) Use of Mobile is strictly prohibited.
- 7) QN- Question No., SQN-Sub Question No. R- Remembering, U- Understanding, A- Application.

QN	S Q N	Section- II	R/ U/ A	Co MEF 503	Mar ks
Q.4		Attempt any FOUR :			08
	a)	Define concrete mix design.	R	4	02
	b)	Enlist any four materials used for formwork.	R	4	02
	c)	Enlist any four properties of hardened concrete.	R	5	02
	d)	State the meaning of M20 grade concrete.	U	5	02
	e)	Enlist any two non-destructive tests on concrete.	R	5	02
	f)	Define Guniting.	R	6	02
Q.5		Attempt any FOUR :			16
	a)	State any four objectives of concrete mix design.	U	4	04
	b)	Explain stepwise IS code method of mix design of concrete.	U	4	04
	c)	Explain stripping time of i) column formwork ii) beam formwork.	R	4	04
	d)	State the factors which affect the water cement ratio.	U	5	04
	e)	Explain the terms durability and impermeability of concrete.	U	5	04
	f)	Explain ultrasonic pulse velocity test method.	U	5	04
Q.6		Attempt any FOUR :			16
	a)	State and explain the factors causing variation in the quality of concrete.	R	5	04
	b)	State aim of inspection and testing of fresh concrete.	U	5	04
	c)	State the precautions to be taken during hot weather concreting.	U	6	04
	d)	Explain deep tremie method of underwater concreting.	U	6	04
	e)	Define ready mix concrete with its advantages.	U	6	04
	f)	State any four field applications of fiber reinforced concrete.	A	6	04

GOVERNMENT POLYTECHNIC, KOLHAPUR – 416004.

(An Autonomous Institute of Govt. Of Maharashtra)

SUMMER-2024

EXAM SEAT NO.

--	--	--	--	--	--

LEVEL: - FOURTH

PROGRAM: CIVIL ENGINEERING

COURSE CODE: - CEG 403 / CEF 403

COURSE NAME: - DESIGN AND DRAFTING OF STEEL STRUCTURES

MAX. MARKS: 80

TIME: 03 Hrs

DATE: - 18 / 5 / 2024

Instruction :-

- 1) All questions are compulsory.
- 2) Answers of two sections must be written in separate section answer book provided.
- 3) Illustrate your answers with sketches wherever necessary.
- 4) Use of non-programmable pocket calculator is permissible.
- 5) Mathematical and other tables is permissible.
- 6) Assume and mention suitable additional data if necessary.
- 7) Use of Mobile phone or other communication device is strictly prohibited.
- 8) Indian standard codes are not allowed but formula sheet attached along with question paper is permissible.
- 9) QN- Question No., SQN-Sub Question No. R- Remembering, U- Understanding, A- Application.

QN	S Q N	SECTION - I	R/ U/ A	Co	Ma rks
Q.1		Attempt any FOUR :			08
	a)	Define limit state method and its types.	R	1	
	b)	Enlist any two IS codes required for design of steel structure.	U	1	
	c)	State long form of i) ISNT ii) ISMC with neat diagram.	R	1	
	d)	Define the following terms with neat sketch i) Pitch distance ii) edge distance	R	2	
	e)	Draw neat sketch of fillet weld joint showing all components.	U	2	
	f)	Define the following terms i) Slenderness ratio ii) effective length	R	3	
Q.2		Attempt any FOUR :			16
	a)	State any four advantages and disadvantages of welded connections over bolted connections.	R	2	
	b)	Explain the function of steel towers, roof truss, steel bridges and crane girders.	U	1	
	c)	Draw stress-strain curve for mild steel with its salient features.	U	1	
	d)	The longer leg of a single angle $90 \times 60 \times 10$ mm is connected to the gusset plate with 3 bolts in a line of 20 mm diameter at a pitch of 60 mm, end distance 40 mm and gauge distance 50 mm, for this tension member determine the block shear strength only.	A	3	
	e)	Enlist two types of sections used as a tension member along with sketches. Also, write function of gusset plate used.	U	3	
	f)	i) A compression member of length 3 m is restrained against translation and rotation at one end, and at other end it is restrained against translation but free for rotation calculate its effective length. ii) A compression member of length 3 m is restrained against translation and rotation at both the ends calculate its effective length.	A	3	
Q.3		Attempt any TWO :			16
	a)	A Double angle $125 \times 75 \times 6$ mm is used as a tension member, longer sides of section are connected to 10mm gusset plate on either side of gusset plate with 5 bolts of 16mm diameter. Bolts are pitched at 50mm and end distance 40 mm, gauge distance 75 mm, find tensile strength of member. Gross area of single angle section is 1166 mm^2	A	3	
	b)	A lap joint consists of two plates of $100 \text{ mm} \times 10 \text{ mm}$ Joint is subjected to 150 kN factored load, design the joint for following two cases i) Use 20mm dia. bolts of grade 4.6. ii) Use fillet weld in field of size 5mm	A	2	
	c)	A discontinuous compression member consists of 2 ISA $90 \times 90 \times 10$ mm connected back to back on opposite sides of 12 mm thick gusset plate and connected by welding. The length of strut is 3 m. It is welded on either side. Calculate design compressive strength of strut. Properties of single angle ISA $90 \times 90 \times 10$, $A_g = 1700 \text{ mm}^2$, $C_{xx} = C_{yy} = 25.9 \text{ mm}$, $I_{xx} = I_{yy} = 1267 \times 10^3 \text{ mm}^4$, $r_{xx} = 27.3 \text{ mm}$	A	3	

GOVERNMENT POLYTECHNIC, KOLHAPUR – 416004
(An Autonomous Institute of Govt. Of Maharashtra)

SUMMER 2024

EXAM SEAT NO.

--	--	--	--	--	--

LEVEL: - **FOURTH** PROGRAM: CIVIL ENGINEERING
 COURSE CODE: CEG 403/ **CEF403**
 COURSE NAME: DESIGN AND DRAFTING OF STEEL STRUCTURE
 MAX. MARKS: **80** TIMES: **3 HRS.**

DATE: - **18/5/2024**

QN	S Q N	Section- II	R/ U/ A	Co MEF 503	Mar ks
Q.4		Attempt any FOUR:			08
	a)	Define laterally restrained Beam.	R	4	
	b)	Draw any four sections used for steel Beam.	U	4	
	c)	Enlist any four types of trusses.	U	6	
	d)	Calculate the live load intensity for roof with 20° slope.	A	6	
	e)	Draw a neat, labeled plan of gusseted base.	U	5	
	f)	Enlist types of column base with their suitability.	U	5	
Q.5		Attempt any FOUR:			16
	a)	Define laterally supported beam along with suitable sketch. State any three methods of providing lateral supports to the beam	R	4	
	b)	Classify the cross sections of beams based on moment-rotation behavior and explain each of them	U	4	
	c)	Differentiate between slab base and gusseted base on any four parameters.	U	5	
	d)	State necessity of column bases, also state the function of cleat angle and anchor bolts in slab base.	R	5	
	e)	A truss of 20 m span has rise of 4.5 m and these trusses are spaced at 5 m c/c. The design wind pressure is 1.65KPa and number of panels are 10. Coefficient of external wind action is - 1.0 and coefficient of internal wind action is ± 0.5 for this data, calculate panel point load for wind load.	A	6	
	f)	Design and angle of purlin for a roof truss for the following data, Spacing of truss=5m, load on purlin=1.5KN/m, allowable stress in bending=165MPa Design for uniaxial bending only.	A	6	
Q.6		Attempt any FOUR:			16
	a)	Draw neat sketch of six panel truss showing main tie, principle rafter, pitch and span. Also state any two uses of steel roof truss	U	6	
	b)	Calculate the panel point load in case of dead load , for a roof truss having rise of truss = 3 m, span of truss = 16 m, spacing of trusses = 3.5 m c/c. No. of panels = 8 Nos., weight of roof covering = 120 N/m ² , weight of purlin = 80 N/m ² and weight of bracing = 75 N/m ²	A	6	
	c)	A pratt roof truss has spacing of 4.1 m, panel length 2.1 m, pitch ¼ and span 16.4 m. No access provided to roof, calculate panel point live load.	A	6	
	d)	An ISMB 250 is used as a simply supported beam of span 3 m to carry factored load of 30 kN/m, assume fy = 250 N/mm ² . For ISMB 250, tw = 6.4 mm & h = 250 mm, check for shear only.	A	4	
	e)	Explain any four components of plate girder with their function.	U	4	
	f)	An ISMB400 is used for a simply supported beam over effective span 6 m. calculate maximum udl it can carry safely. Ixx= 20458x 10 ⁴ mm ⁴ , and tw=8.9mm respectively. Assume allowable bending stress = 165 MPa			

Table 2 Limiting Width to Thickness Ratio

Cavallari

(Clauses 3.7.2 and 3.7.4)

Compression Element (1)		Ratio (2)	Class of Section			
			Class 1 Plastic (3)	Class 2 Compact (4)	Class 3 Semi-compact (5)	
Outstanding element of compression flange	Rolled section	b/t_f	9.4ϵ	10.5ϵ	15.7ϵ	
	Welded section	b/t_f	8.4ϵ	9.4ϵ	13.6ϵ	
Internal element of compression flange	Compression due to bending	b/t_f	29.3ϵ	33.5ϵ	42ϵ	
	Axial compression	b/t_f	Not applicable			
Web of an I, H or box section	Neutral axis at mid-depth		d/t_w	84ϵ	105ϵ	126ϵ
	Generally	If r_1 is negative:	d/t_w	$\frac{84\epsilon}{1+r_1}$	$\frac{105.0\epsilon}{1+r_1}$	$\frac{126.0\epsilon}{1+2r_1}$
		If r_1 is positive:	d/t_w	but $\leq 42\epsilon$	$\frac{105.0\epsilon}{1+1.5r_1}$ but $\leq 42\epsilon$	but $\leq 42\epsilon$
	Axial compression		d/t_w	Not applicable		42ϵ
Web of a channel		d/t_w	42ϵ	42ϵ	42ϵ	
Angle, compression due to bending (Both criteria should be satisfied)		b/t	9.4ϵ	10.5ϵ	15.7ϵ	
		d/t	9.4ϵ	10.5ϵ	15.7ϵ	
Single angle, or double angles with the components separated, axial compression (All three criteria should be satisfied)		b/t d/t $(b+d)/t$	Not applicable			15.7ϵ 15.7ϵ 25ϵ
Outstanding leg of an angle in contact back-to-back in a double angle member		d/t	9.4ϵ	10.5ϵ	15.7ϵ	
Outstanding leg of an angle with its back in continuous contact with another component		d/t	9.4ϵ	10.5ϵ	15.7ϵ	
Stem of a T-section, rolled or cut from a rolled I-or H- section		D/t_f	8.4ϵ	9.4ϵ	18.9ϵ	
Circular hollow tube, including welded tube subjected to:		a) moment	D/t	$42\epsilon^2$	$52\epsilon^2$	$146\epsilon^2$
		b) axial compression	D/t	Not applicable		$88\epsilon^2$
<p>NOTES</p> <p>1 Elements which exceed semi-compact limits are to be taken as of slender cross-section.</p> <p>2 $\epsilon = (250 / f_y)^{1/2}$</p> <p>3 Webs shall be checked for shear buckling in accordance with 8.4.2 when $d/t > 67\epsilon$, where, b is the width of the element (may be taken as clear distance between lateral supports or between lateral support and free edge, as appropriate), t is the thickness of element, d is the depth of the web, D is the outer diameter of the element (see Fig. 2, 3.7.3 and 3.7.4).</p> <p>4 Different elements of a cross-section can be in different classes. In such cases the section is classified based on the least favourable classification.</p> <p>5 The stress ratio r_1 and r_2 are defined as:</p> <p>$r_1 = \frac{\text{Actual average axial stress (negative if tensile)}}{\text{Design compressive stress of web alone}}$</p> <p>$r_2 = \frac{\text{Actual average axial stress (negative if tensile)}}{\text{Design compressive stress of overall section}}$</p>						

$$V_{nsb} = \left(\frac{f_u}{\sqrt{3}}\right) (n_n A_{nb} + n_s A_{sb}), \quad V_{dsb} = \frac{V_{nsb}}{\gamma_{mb}}, \quad V_{dpb} = \frac{V_{npb}}{\gamma_{mb}}$$

$$T_{dg} = \frac{A_g f_y}{\gamma_{m0}}$$

$$V_{npb} = 2.5 k_b d t f_u$$

k_b is smaller of $\frac{e}{3d_0}$, $\frac{p}{3d_0}$, $\frac{f_{ub}}{f_u}$, & 1

$$T_{dn} = \frac{0.9 A_{nc} f_u}{\gamma_{m1}} + \beta \frac{A_{go} f_y}{\gamma_{m0}} \quad \text{where } \beta = 1.4 - 0.076 (w/t) (f_y/f_w) (bs/L_c) \leq (f_u \gamma_{m0} / f_y \gamma_{m1}) \geq 0.7$$

$$T_{dn} = \frac{\alpha A_n f_u}{\gamma_{m1}}, \quad T_{db1} = \frac{A_{vg} f_y}{\sqrt{3} \gamma_{m0}} + \frac{0.9 A_{ul} f_u}{\gamma_{m1}}, \quad T_{db2} = \frac{0.9 A_{vn} f_u}{\sqrt{3} \gamma_{m1}} + \frac{A_{ig} f_y}{\gamma_{m0}}$$

$$P_d = A_e f_{cd}$$

$$P_z = 0.6 V_z^2$$

$$V_z = V_b k_1 k_2 k_3$$

$$f_{cd} = \chi \frac{f_y}{\gamma_{m0}}$$

$$\chi = \frac{1}{\phi + \sqrt{\phi^2 - \lambda_c^2}}$$

where $\phi = 0.5[1 + \alpha(\lambda_e - 0.2) + \lambda_e^2]$

$$\lambda_e = \sqrt{k_1 + k_2 \lambda_w^2 + k_3 \lambda_\phi^2}$$

where

$$\lambda_w = \frac{\left(\frac{l}{r_w}\right)}{\epsilon \sqrt{\frac{\pi^2 E}{250}}} \quad \text{and} \quad \lambda_\phi = \frac{(b_1 + b_2)/2t}{\epsilon \sqrt{\frac{\pi^2 E}{250}}}$$

$$M_{de} = \frac{\beta_b \times Z_p \times f_y}{\gamma_{m0}}$$

$$V_{dz} = \frac{f_y \times t_w \times h}{\gamma_{m0} \times \sqrt{3}}$$

$$t_s = \sqrt{[2.5w(a^2 - 0.3b^2)\gamma_{m0} / f_y]} > t_f$$

Values of χ and f_{cd} (N/mm^2) for different values of KL/r_{min} as per buckling curve 'c'

KL/r_{min}	10	20	30	40	50	60	70	80	90
χ	1.000	0.987	0.930	0.870	0.807	0.740	0.670	0.600	0.533
f_{cd}	227	224	211	198	183	168	152	136	121

KL/r_{min}	100	110	120	130	140	150	160	170	180
χ	0.471	0.416	0.368	0.327	0.291	0.261	0.234	0.212	0.192
f_{cd}	107	94.6	83.7	74.3	66.2	59.2	53.3	48.1	43.6

Constants k_1, k_2, k_3 for design of single angle strut.

No. of bolts	Fixing	k_1	k_2	k_3
≥ 2	Fixed/Weld	0.20	0.35	20
	Hinged	0.70	0.60	5
↓	Fixed	0.75	0.35	20
	Hinged	1.25	0.50	60

GOVERNMENT POLYTECHNIC, KOLHAPUR – 416004.

(An Autonomous Institute of Govt. Of Maharashtra)

SUMMER-2024

EXAM SEAT NO.

--	--	--	--	--	--

LEVEL :- *Third* PROGRAM : Civil Engineering

COURSE CODE :- CEH 302

COURSE NAME :- Surveying

MAX. MARKS : 70

TIME : 03 Hrs

DATE :- 18/5/2024

Instruction :-

- 1) Answers of two sections must be written in separate section answer book provided.
- 2) Illustrate your answers with sketches wherever necessary.
- 3) Use of non-programmable pocket calculator is permissible.
- 4) Mathematical and other tables shall be made available on request.
- 5) Assume and mention suitable additional data if necessary.
- 6) Use of Mobile is strictly prohibited.
- 7) QN- Question No., SQN-Sub Question No. R- Remembering, U- Understanding, A- Application.

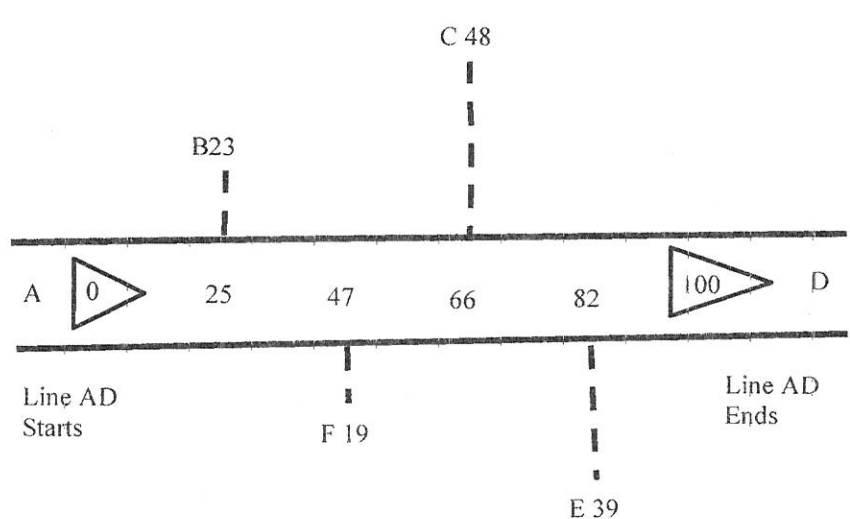
QN	S Q N	Question Text	R/ U/ A	Co CEH 302	Ma rks
Q.1		Attempt any THREE: (2 X 3)			06
	a)	Explain in brief reconnaissance survey	R	1	
	b)	Enlist the types of meridian	R	2	
	c)	Write any four uses of surveying	R	1	
	d)	State the principle of plane table survey	R	3	
	e)	Draw conventional symbols for chain line and boundary line	U	1	
Q.2		Attempt any FOUR: (4 X 4)			16
	a)	Define offset and explain its types with neat sketches	U	2	
	b)	Differentiate between radiation and intersection	U	3	
	c)	Convert the following bearings into relevant bearings i) $179^{\circ} 40'$ ii) $365^{\circ} 20'$ iii) $N 12^{\circ} W$ iv) $S 68^{\circ} 15' E$	A	2	
	d)	Enlist the accessories of plane table and write the uses of any two	U	3	
	e)	Describe the field procedure of chain survey	A	2	
	f)	Write any four component parts of prismatic compass with their uses	U	2	
Q.3		Attempt any TWO: (6 X 2)			12
	a)	Plot the following cross staff survey of a field and calculate its area in M^2 . All observations are in M. 	A	2	

P.T.O.

	<p>b) Following bearings were observed for traverse PQRST. Identify stations affected by local attraction and find corrected bearings of lines.</p> <table border="1" data-bbox="272 440 1279 710"> <thead> <tr> <th>Line</th> <th>FB</th> <th>BB</th> </tr> </thead> <tbody> <tr> <td>PQ</td> <td>68° 15'</td> <td>248° 15'</td> </tr> <tr> <td>OR</td> <td>148° 45'</td> <td>326° 15'</td> </tr> <tr> <td>RS</td> <td>224° 30'</td> <td>46° 0'</td> </tr> <tr> <td>ST</td> <td>217° 15'</td> <td>38° 15'</td> </tr> <tr> <td>TP</td> <td>327° 45'</td> <td>147° 45'</td> </tr> </tbody> </table>	Line	FB	BB	PQ	68° 15'	248° 15'	OR	148° 45'	326° 15'	RS	224° 30'	46° 0'	ST	217° 15'	38° 15'	TP	327° 45'	147° 45'	A	2	
Line	FB	BB																				
PQ	68° 15'	248° 15'																				
OR	148° 45'	326° 15'																				
RS	224° 30'	46° 0'																				
ST	217° 15'	38° 15'																				
TP	327° 45'	147° 45'																				
	<p>c) i) Write merits and demerits of plane table survey ii) Classify surveying on the basis of instruments</p>	R U	3 1																			

P.T.O. 2/3

GOVERNMENT POLYTECHNIC, KOLHAPUR – 416004.

(An Autonomous Institute of Govt. Of Maharashtra)

SUMMER-2024**EXAM SEAT NO.**

--	--	--	--	--	--	--

LEVEL: - III

PROGRAM: Civil Engineering

COURSE CODE: - CEH 302

COURSE NAME: - Surveying

MAX. MARKS: 70

TIME: 03 Hrs

DATE: -18/5/2024

QN	S Q N	Question Text	R/ U/ A	Co	Ma rks
Q.4		Attempt any FOUR: (2 X 4)			08
	a)	Define Latitude & Departure.	U	5	
	b)	What are the types of theodolite?	R	5	
	c)	State the relationships between fundamental lines of theodolite.	U	5	
	d)	Define the terms: Back sight and Fore sight	R	4	
	e)	What do you mean by Level surface, Change point?	R	4	
	f)	List various types of bench mark.	R	4	
Q.5		Attempt any FOUR: (4 X 4)			16
	a)	Explain how construction of Auto level is different from that of Dumpy level.	U	4	
	b)	What are the different methods of contouring? Describe any one with neat sketch.	U	4	
	c)	Explain the Direct method of horizontal angle measurement.	U	5	
	d)	What are the temporary adjustments of dumpy level?	R	4	
	e)	Give the functions of the following components of transit theodolite: a) Upper clamp screw b) Foot screws c) Vertical circle clamp screw d) Focusing screw	R	5	
	f)	Explain included angle method of theodolite traversing.	R	5	
Q.6		Attempt any TWO: (6 X 2)			12
	a)	State and explain types of leveling.	U	4	
	b)	What are the various rules applied for balancing of Traverse? Explain any one.	U	5	
	c)	The following consecutive readings were taken with a level and a 4-meter leveling staff on a continuously sloping ground at a common interval of 30 m. 0.855 (On A), 1.545, 2.335, 3.115, 3.825, 0.455, 1.380, 2.055, 2.855, 3.455, 0.585, 1.015, 1.850, 2.755, 3.845 (On B) The RL of A was 380.500 m. Rule out page of a level field book and enters the above readings. Calculate the reduced level of the points by Rise and fall method also determine the gradient of line AB. Apply usual checks.	A	4	

GOVERNMENT POLYTECHNIC, KOLHAPUR – 416004

(An Autonomous Institute of Govt. Of Maharashtra)

SUMMER 2024EXAM SEAT NO.

--	--	--	--	--	--

LEVEL: - Third

PROGRAM: **Civil Engineering****COURSE CODE: - CEG308/CEF308****COURSE NAME: Surveying -I****MAX. MARKS: 80 TIME: 3 HRS. DATE: - 17 May 2024**

Instruction: -

- 1) Answers must be written in the main answer book provided (and supplements if required).
- 2) Illustrate your answers with sketches wherever necessary.
- 3) Use of non-programmable pocket calculator is permissible.
- 4) Mathematical and other tables shall be made available on request.
- 5) Assume and mention suitable additional data if necessary.
- 6) Use of Mobile is strictly prohibited.
- 7) QN- Question No., SQN-Sub Question No. R- Remembering, U- Understanding, A- Application.

QN	S QN	Question Text	R/ U/ A	CO	Marks
Q.1		Attempt any FOUR :			08
	a)	Define Surveying.	R	1	
	b)	State any two principles of surveying.	U	1	
	c)	State any four duties of Leader.	A	1	
	d)	Define Ranging.	R	1	
	e)	State any two uses of prismatic compass.	U	3	
	f)	Define Bearing of line	R	3	
Q.2		Attempt any FOUR :			16
	a)	State the classification of surveying based upon the instruments employed.	U	1	
	b)	Describe the method of chaining on sloping grand.	U	1	
	c)	Enlist the obstacles in chaining explain any one method to overcome obstacles.	U	2	
	d)	Draw conventional symbols for the following I)River II)Tunnel III) Transmission Line IV) Cultivated land.	A	2	
	e)	Draw a neat labeled sketch of Prismatic Compass.	U	3	
	f)	Describe in detail method of Traversing with chain and compass survey.	U	3	
Q.3		Attempt any FOUR :			16
	a)	Describe the procedure of indirect ranging with neat sketch.	R	1	
	b)	State the errors in Chaining. Explain any one.	U	1	
	c)	Define i) Perpendicular offset ii) Oblique offset with neat sketch	R	2	

P.T.O.

1/3

	d)	Differentiate between i) WCB & RB (whole circle bearing & reduced bearing) ii) FB & BB (Fore bearing & back bearing)	U	2																
	e)	Explain in brief graphical adjustment of closing error in Traversing with the help of Bowditch's rule.	U	3																
	f)	Following table shows bearing observed for a closed traverse . <table border="1" style="margin-left: auto; margin-right: auto;"><thead> <tr> <th>Line</th> <th>AB</th> <th>BC</th> <th>CD</th> <th>DA</th> </tr> </thead> <tbody> <tr> <td>F B</td> <td>75°30'</td> <td>19°45'</td> <td>289°30'</td> <td>359°00'</td> </tr> <tr> <td>B B</td> <td>260°0'</td> <td>10°15'</td> <td>109°30'</td> <td>176°0'</td> </tr> </tbody> </table> Calculate i) included angle ii) corrected bearing of each line.	Line	AB	BC	CD	DA	F B	75°30'	19°45'	289°30'	359°00'	B B	260°0'	10°15'	109°30'	176°0'	A	3	
Line	AB	BC	CD	DA																
F B	75°30'	19°45'	289°30'	359°00'																
B B	260°0'	10°15'	109°30'	176°0'																
Q.4		Attempt any FOUR :			08															
	a)	Define i) Level surface ii) Line of collimation	R	4																
	b)	What is a Least count of i) 4m levelling staff ii) prismatic compass	U	4																
	c)	State any four instruments used for Levelling.	R	4																
	d)	What is zero circle?	U	6																
	e)	Define i) Contour ii) Horizontal equivalent	R	5																
	f)	Draw Contour to represent the following feature i) Hill ii) Valley	U	5																
Q.5		Attempt any TWO :			16															
	a)	The following are the consecutive readings taken with a dumpy level 0.895, 1.650, 2.900, 3.020, 0.960, 0.700, 0.590, 0.245, 1.550, 0.995 & 2.140 The instruments was shifted after fourth & eighth reading . The first reading was taken on staff held on B. M of RL 200.250m, Rule out a page of level field book, enter the above readings. Calculate reduced level of all parts by Line of collimation method. Apply Checks as usual.	A	4																
	b)	I) Explain in brief Temporary adjustment of Dumpy Level. II) What are the sources of errors in levelling explain any one.	U U	4 4																
	c)	I) Describe various methods of contouring and explain any one. II) Calculate the area of the figure transversed clockwise with another point inside and the tracing arm to give the multiplying constant = 100 sq.cm and additive constant C= 20 IR =3.435 , F.R =8.950, The zero mark of the dial passed the fixed index once in reverse direction.	A A	5 6																

Q.6	Attempt any TWO ,			16
a)	The following consecutive Readings were taken with a level and 4m staff a continuously sloping ground at a common interval of 30m. 0.760, 1.520, 1.950, 2.400, 2.995, 3.650, 1.025, 1.855, 2.490, 3.870, 0.900, 1.050, 1.800, & 2.350. The RL of the first point was 500.00m Rule out a page of level field book & enter the above readings. Calculate the Reduced levels of all points by Rise & Fall method and also the gradient of the line joining the first & last point.	A	4	
b)	I) Describe in detail the process of profile leveling II) Define the following terms i) Bench mark ii) Change point iii) Datum iv) Back sight	U	4	
c)	I) State any four important characteristics of contour with neat sketches. II) Describe the procedure of using Digital planimeter and state any two uses.	U U	5 6	

GOVERNMENT POLYTECHNIC, KOLHAPUR – 416004.

(An Autonomous Institute of Govt. Of Maharashtra)

SUMMER- 2024

EXAM SEAT NO.

--	--	--	--	--	--

LEVEL :- IV

PROGRAM : Civil Engineering

COURSE CODE :- CEG 404/CEF404

COURSE NAME :- Estimating and Costing

MAX. MARKS : 80 TIME : 04 Hrs

DATE :- 17/5/2024

Instruction :-

- 1) Answers of two sections must be written in separate section answer book provided.
- 2) Illustrate your answers with sketches wherever necessary.
- 3) Use of non-programmable pocket calculator is permissible.
- 4) Mathematical and other tables shall be made available on request.
- 5) Assume and mention suitable additional data if necessary.
- 6) Use of Mobile is strictly prohibited.
- 7) QN- Question No., SQN-Sub Question No. R- Remembering, U- Understanding, A- Application.

QN	S Q N	SECTION - I	R/ U/ A	Co	Ma rks
Q.1		Attempt any FOUR :			08
	a)	State any two objective of approximate estimate	U	1	
	b)	Give provisions made in the estimate for Contingencies and Centage charges	R	2	
	c)	What is maintenance estimate	R	2	
	d)	Give format of abstract sheet	R	3	
	e)	Give format of Bar Bending Schedule	R	3	
	f)	What are the modes of measurements of Excavation and Plastering	R	1	
Q.2		Attempt any FOUR :			16
	a)	Explain the importance of Work charge Establishment and Contingencies in estimate	A	2	
	b)	Differentiate between Revised Estimate and Supplementary Estimate	U	2	
	c)	Explain with suitable example center line method	U	3	
	d)	What do you mean by checklist? Prepare checklist for load bearing residential building	U	1	
	e)	What are the factors to be considered during preparation of detailed estimate	R	2	
	f)	State units if measurements for - i) P.C.C. (1:3:6) ; 2) Aluminum Door ; 3) Filling in plinth with Hard Murum ; 4) Dado	R	1	
Q.3		Attempt any TWO :			16
	a)	i) Prepare Approximate Estimate of a Building with plinth area of 590 sqm. Cost of existing similar type of building is Rs. 10,00,000 whose plinth area is 90sqm ; ii) Prepare Approximate Estimate of a bridge having 3 spans of 40 m each using following data; Cost of existing bridge is 1 crores. Existing bridge is having 4 spans of 50 m each	A	1	
	b)	Fig No. 1 Shows a plan of a building and section of wall. Calculate the quantities of any two items of work given below and enter in standard measurement sheet. Plinth height is 600 mm and depth of excavation is 1.52 Mt i) Excavation for Foundation ii) 1:2:4 concrete for lintels iii) Filling in plinth (Murum Filling) iv) Skirting tiles in sqm. for Rooms Consider height of skirting as 15cm	A	3	

(P.T.O)

GOVERNMENT POLYTECHNIC, KOLHAPUR – 416004.

(An Autonomous Institute of Govt. Of Maharashtra)

SUMMER-2024

EXAM SEAT NO.

LEVEL :- FOUR

PROGRAM : CIVIL ENGINEERING

COURSE CODE :- CEG 404/CEF404

COURSE NAME :- ESTIMATING AND COSTING

MAX. MARKS : 80

TIME : 04Hrs

DATE :-17/5/2024

QN	S Q N	SECTION -II	R/ U/ A	Co CEG 404	Ma rks																		
Q.4		Attempt any FOUR :			08																		
	a)	Define specification.	R	04																			
	b)	State any two points you will consider while framing specification.	U	04																			
	c)	State any four data required for rate analysis.	R	05																			
	d)	Define task work.	R	05																			
	e)	Give prismoidal formula along with meaning of terms.	R	06																			
	f)	Define rate analysis.	R	05																			
Q.5		Attempt any FOUR :			16																		
	a)	State different types of specifications. Explain any one in brief.	R	04																			
	b)	Explain factors affecting rate analysis.	U	05																			
	c)	Calculate the quantities of materials required for 25 m ³ UCR masonry in CM 1:4.	A	05																			
	d)	Give the market rates for following materials i) Cement bag ii) Reinforcement Steel iii) Coarse aggregate iv) Oil Paint	R	05																			
	e)	Enlist methods of calculation of earthwork quantity. Explain any one in detail.	R	06																			
	f)	Calculate quantities of earthwork from following data: Formation width = 10m. Slope in cutting = 1.5:1(H:V) Slope in banking = 2:1 (H:V). Use mean area method.	A	06																			
		<table border="1" style="width:100%; border-collapse: collapse;"> <tr> <td>Chainage in m</td> <td>0</td> <td>50</td> <td>100</td> <td>150</td> <td>200</td> </tr> <tr> <td>Ground level</td> <td>500</td> <td>499.30</td> <td>498.45</td> <td>494.90</td> <td>494.00</td> </tr> <tr> <td>Formation level</td> <td>496.5</td> <td>496</td> <td>496.50</td> <td>495.00</td> <td>494.50</td> </tr> </table>			Chainage in m	0	50	100	150	200	Ground level	500	499.30	498.45	494.90	494.00	Formation level	496.5	496	496.50	495.00	494.50	
Chainage in m	0	50			100	150	200																
Ground level	500	499.30	498.45	494.90	494.00																		
Formation level	496.5	496	496.50	495.00	494.50																		
Q.6		Attempt any TWO :			16																		
	a)	Draft a detailed specification for cement plaster 1:6 for a brick wall.	U	04																			
	b)	Prepare rate analysis for brickwork in superstructure in c.m. 1:6 for 10 cu.m.	A	05																			
	c)	Calculate the quantities of earthwork in cutting and in banking for a portion of road with following data:- 1)formation width of road is 12m 2)formation level of starting chainage is 51.50m 3)the road surface shall be given falling gradient of 1 in 200 4)side slopes are 1V:2H banking and 1V:1.5H in cutting.	A	06																			
		<table border="1" style="width:100%; border-collapse: collapse;"> <tr> <td>Chainage in m</td> <td>0</td> <td>30</td> <td>60</td> <td>90</td> <td>120</td> <td>150</td> <td>180</td> </tr> <tr> <td>G.L. in m</td> <td>50.80</td> <td>50.60</td> <td>50.70</td> <td>51.20</td> <td>51.40</td> <td>51.30</td> <td>51.00</td> </tr> </table>			Chainage in m	0	30	60	90	120	150	180	G.L. in m	50.80	50.60	50.70	51.20	51.40	51.30	51.00			
Chainage in m	0	30			60	90	120	150	180														
G.L. in m	50.80	50.60	50.70	51.20	51.40	51.30	51.00																

GOVERNMENT POLYTECHNIC, KOLHAPUR – 416004.

(An Autonomous Institute of Govt. Of Maharashtra)

EVEN TERM END EXAM SUMMER -2024

EXAM SEAT NO.

LEVEL :- FOURTH

PROGRAM : CIVIL ENGINEERING

COURSE CODE :- CEG401/CEF401

COURSE NAME ANALYSIS OF STRUCTURE

MAX. MARKS : 80 TIME : 03Hrs.

DATE :- 16/05/2024

Instruction :-

- 1) Answers must be written in the main answer book provided.(and supplements if required)
- 2) Illustrate your answers with sketches wherever necessary.
- 3) Use of non-programmable pocket calculator is permissible.
- 4) Mathematical and other tables shall be made available on request.
- 5) Assume and mention suitable additional data if necessary.
- 6) Use of Mobile is strictly prohibited.
- 7) QN- Question No., SQN-Sub Question No. R- Remembering, U- Understanding, A- Application.

QN	S Q N	SECTION -I	R/ U/ A	Co CEG 401	Mar ks
Q.1		Attempt any FOUR :			08
	a)	Define perfect and imperfect frames.	R	1	
	b)	Define principal planes and principal stresses.	R	2	
	c)	State the middle third rule.	R	3	
	d)	Draw the stress distribution diagram, for the section when i) Direct stress > Bending stress. ii) Direct stress = Bending stress.	U	3	
	e)	Define short column and long column.	R	4	
	f)	State the assumptions in the Euler's theory.	A	4	
Q.2		Attempt any FOUR :			16
	a)	For the truss shown in fig., determine nature and magnitude of forces in members BC, CE, AE and DE. Use method of joints.	A	1	
	b)	The principal tensile stresses at a point across two perpendicular planes are 10 MPa and 5 MPa both tensile. Find the normal tangential and resultant stresses on a plane at 20 degree with the major principal plane.	U	2	
	c)	A rectangular pier is 300 mm wide and 200 mm thick. It carries a load of 100 kN at an eccentricity of 40 mm in a plane bisecting the thickness. Find the maximum and minimum stress intensities in the section.	A	3	
	d)	A short masonry pillar is 500 mm × 500 mm in section. At what eccentricity a point load of 8000 kN placed on one of the centroidal axis of the section be acting so as to produce no tension in the section.	U	3	
	e)	A column having height 8m is hinged at both the ends. The cross section is a rectangle with dimensions, 80 mm × 120 mm. Calculate Euler's buckling load, Take E = 200GPa.	U	4	
	f)	A C.I. hollow cylindrical column has 200 mm external diameter, 20 mm thickness and 8m long. Determine the safe load using Rankine's theory with $\sigma_c = 560$ MPa, $a = 1/1600$ and factor of safety = 6, assume both ends are fixed.	A	4	

P T O

1/4

Q.3	Attempt any TWO:			16
a)	Using the method of sections, find the forces in the members of the truss as shown in fig. <i>members AB, BE & ED</i>	U	1	
b)	At a point in a structure, the stresses are 150 MPa and 50 MPa both tensile. Find by Mohr's circle method, the intensities of normal, shear and resultant stresses on a plane inclined at an angle of 55 degree with the axis of major tensile stress. Also determine the maximum shear stresses and the normal stress on the plane of maximum shear stress.	A	2	
c)	A circular chimney having external diameter three times internal diameter and 8 m height is subjected to wind pressure 1.5 kN/m ² . Weight of masonry is 20 kN/m ³ . Calculate the external and internal diameter, so that no tension will develop in the masonry. Sketch the stress distribution. Coefficient of wind resistance is 0.6.	A	3	

Q.2 a)

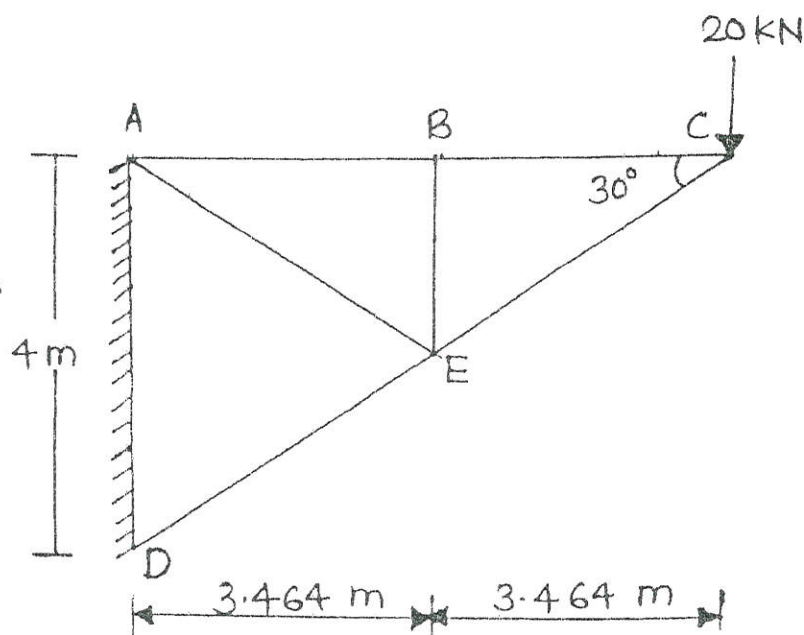

Q.3(a)

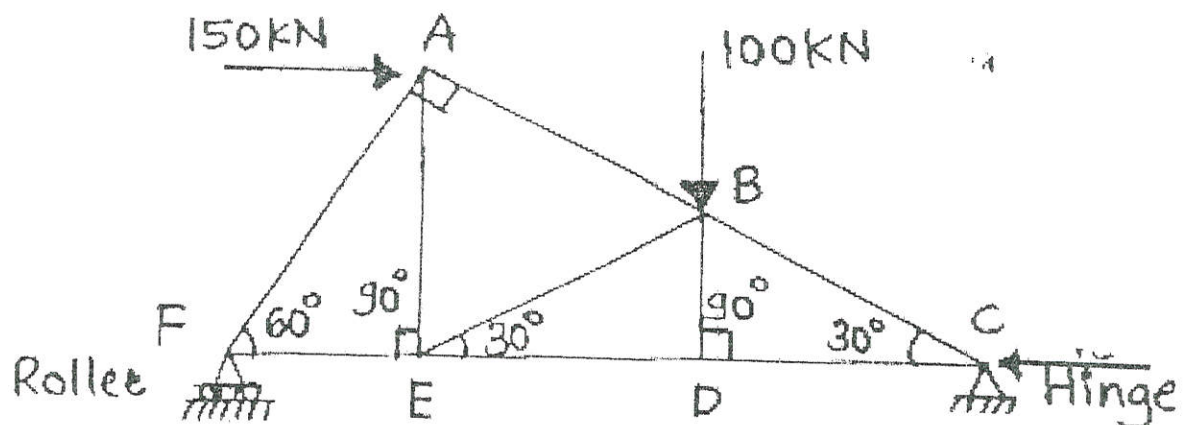

GOVERNMENT POLYTECHNIC, KOLHAPUR – 416004.

(An Autonomous Institute of Govt. Of Maharashtra)

SUMMER 2024

EXAM SEAT NO.

--	--	--	--	--	--

LEVEL :- FOURTH

PROGRAM : Civil Engineering

COURSE CODE :- CEG 401/ CEF 401

COURSE NAME :- ANALYSIS OF STRUCTURE

MAX. MARKS : 80 TIME : 03 Hrs

DATE :- 16/5/2024

Instruction :-

- 1) Answers of two sections must be written in separate section answer book provided.
- 2) Illustrate your answers with sketches wherever necessary.
- 3) Use of non-programmable pocket calculator is permissible.
- 4) Mathematical and other tables shall be made available on request.
- 5) Assume and mention suitable additional data if necessary.
- 6) Use of Mobile is strictly prohibited.
- 7) QN- Question No., SQN-Sub Question No. R- Remembering, U- Understanding, A- Application.

QN	S Q N	SECTION -II	R/ U/ A	CO	Ma rks
Q.4		Attempt any FOUR :			08
	a)	Define a fixed beam.	R	CEG 401- 5	
	b)	State any two advantages of a continuous beam.	U	CEG 401- 5	
	c)	Define carry over moment	R	CEG 401- 5	
	d)	State the formula for slope and deflection of a simply supported beam AB at ends A and B, if the beam carries u.d.l. 'w' over entire span 'L'	U	CEG 401- 6	
	e)	A fixed beam AB of span 8m carries u.d.l. of 3 kN/m over entire span along with a point load of 12 kN at the centre of the span. Calculate fixed end moments	A	CEG 401- 5	
	f)	A cantilever of span 3.5 m carries a point load at the free end. If maximum slope at the free end is 1° , determine maximum deflection.	A	CEG 401- 6	
Q.5		Attempt any FOUR :			16
	a)	A simply supported beam is subjected to two point loads of 20 kN and 40 kN at 2 m and 6 m from the left support respectively. The span of the beam is 8 m. Calculate the deflection under point load of 40 kN by Macaulay's method. $E = 2 \times 10^5 \text{ N/mm}^2$, $I_{XX} = 3 \times 10^8 \text{ mm}^4$	A	CEG 401- 6	
	b)	A cantilever beam 200 mm wide and 300 mm deep having span 2 m and carries a point load of 50 kN at a distance of 1m from fixed end. Find slope and deflection of the cantilever beam at the free end.	A	CEG 401- 6	
	c)	A continuous beam ABC is simply supported at A, B and C. AB = 6 m, BC = 5 m. AB carries a u.d.l. of 30 kN/m and BC of 25 kN/m. Calculate support moments using theorem of three moments. And draw BMD	A	CEG 401- 5	

[3/4]

	d)	A fixed beam of 8 m span is subjected to u.d.l. of 3 kN/m over entire span with a point load of 10 kN acting at center. Calculate net bending moment at center. Also draw BMD.	A	CEG 401- 5	
	e)	A continuous beam ABCD is supported at A, B and C with Cd as overhang. AB is loaded with point load of 12 kN at center of AB, BC is loaded with a point load of 12 kN applied at 3 m from C and a point load of 2 kN at D. AB = 6 m, BC = 8 m and CD = 1 m. Calculate support moments using moment distribution method	A	CEG 401- 5	
	f)	State advantages and disadvantages of fixed beam.	R	CEG 401- 5	
Q.6		Attempt any FOUR :			16
	a)	Calculate support moments by three moment theorem and draw BMD for the beam as shown in figure No. a)	A	CEG 401- 5	
	b)	A fixed beam AB of span 6 m carries point loads of 200 kN and 150 kN at 2m and 4m from left support. Calculate fixed end moments and the reactions at the support. Draw SFD and BMD.	A	CEG 401- 5	
	c)	A continuous beam ABCD is supported at A, B and C with Cd as overhang. AB is loaded with point load of 12 kN at center of AB, BC is loaded with a point load of 12 kN applied at 3 m from C and a point load of 2 kN at D. AB = 6 m, BC = 8 m and CD = 1 m. Draw BMD. Use Clapeyron's three moment theorem.	A	CEG 401- 5	
	d)	A continuous beam ABC is simply supported at A, B and C. AB = 6 m, BC = 5 m. AB carries a u.d.l. of 30 kN/m and BC of 25 kN/m. Calculate support moments using moment distribution method.	A	CEG 401- 5	
	e)	A cast iron beam 40 mm wide x 80 mm deep is simply supported over a span of 1 m. it showed a deflection of 3mm under a central point load of 25 kN. Calculate the modulus of elasticity and the slope at the supports.	A	CEG 401- 6	
	f)	A continuous beam is supported and loaded as shown in figure No. b) Calculate support moments by using moment distribution method.	A	CEG 401- 5	

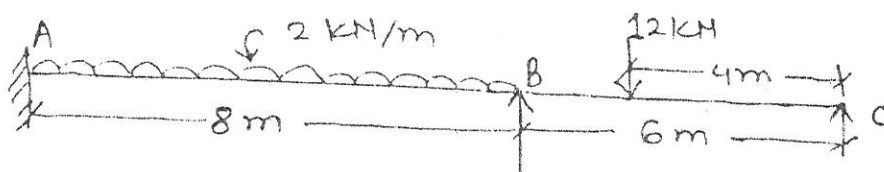

Figure No. a)

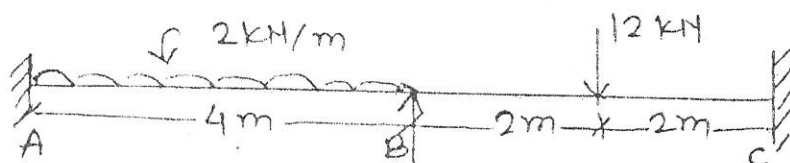

Figure No. b)

GOVERNMENT POLYTECHNIC, KOLHAPUR – 416004.

(An Autonomous Institute of Govt. Of Maharashtra)

EVEN TERM END EXAM SUMMER -2024**EXAM SEAT NO.**

--	--	--	--	--	--

LEVEL :- **THIRD**PROGRAM : **CIVIL ENGINEERING**COURSE CODE :- **CEG311**COURSE NAME **ADVANCED CONSTRUCTION TECHNIQUES AND EQUIPMENTS**MAX. MARKS : **80** TIME : **03Hrs.**DATE :- **16/05/2024**

Instruction :-

- 1) Answers must be written in the main answer book provided.(and supplements if required)
- 2) Illustrate your answers with sketches wherever necessary.
- 3) Use of non-programmable pocket calculator is permissible.
- 4) Mathematical and other tables shall be made available on request.
- 5) Assume and mention suitable additional data if necessary.
- 6) Use of Mobile is strictly prohibited.
- 7) QN- Question No., SQN-Sub Question No. R- Remembering, U- Understanding, A- Application.

QN	S Q N	Question Text	R/ U/ A	Co CEG 311	Mar ks
Q.1		Attempt any FOUR :			08
	a)	Define self healing concrete.	R	1	
	b)	State any two necessity of grouting.	R	1	
	c)	List any two advanced piling techniques.	R	2	
	d)	Enlist any two uses of micro piles.	U	2	
	e)	What is slip formwork?	R	3	
	f)	State any two necessity of form work.	U	3	
Q.2		Attempt any FOUR :			16
	a)	Explain with neat sketch Tremy method of under water concreting.	A	1	
	b)	List any four equipments used for grouting and explain any one.	U	1	
	c)	Describe any four uses of Fiber reinforced concrete.	A	1	
	d)	Explain with sketch slope stabilization in cutting.	A	2	
	e)	Explain in brief Soil Nailing? Where it is use.	U	2	
	f)	Write stripping time for removal of formwork for any four structural members.	U	3	
Q.3		Attempt any FOUR :			16
	a)	Explain in brief any four uses of groutes in building.	U	1	
	b)	What is High Strength concrete? State any two situations where it is used.	A	1	
	c)	State and explain Drilling pattern of grouting for Dams.	U	1	
	d)	Explain in brief sand drains.	A	2	
	e)	What is Mairan formwork? List any four advantages of it.	A	3	
	f)	Explain in brief the procedure of concreting with slip formwork.	U	3	

P.T.O

QN	S Q N	Question Text	R/ U/ A	Co CEG 311	M ar ks
Q.4		Attempt any FOUR :			08
	a)	State any two uses of rammer.	R	4	
	b)	Enlist any four hoisting equipments.	R	4	
	c)	List any four types of trucks used for conveying materials.	R	4	
	d)	State any two uses of needle vibrator.	R	5	
	e)	What is bitumen paver?	U	5	
	f)	State meaning of special equipments.	U	6	
Q.5		Attempt any FOUR :			16
	a)	Draw a neat sketch of crawler crane and label its parts.	A	4	
	b)	State any four uses of dumpers.	U	4	
	c)	Discuss the working of scraper with a neat sketch.	A	4	
	d)	Write a short note on plain roller.	U	4	
	e)	Explain in short loader with back hoe with a neat sketch.	U	4	
	f)	Write note on production of artificial sand.	R	5	
Q.6		Attempt any FOUR :			16
	a)	Explain the working of transit mixer.	U	5	
	b)	State the types of stone crushers and explain any one.	U	5	
	c)	State any four uses of surface vibrator.	A	5	
	d)	Explain in detail working of hot mix bitumen plant and its advantages.	U	5	
	e)	State and discuss any four points to be considered for selection of equipment.	U	6	
	f)	Write a note on equipment management in construction industry.	A	6	

GOVERNMENT POLYTECHNIC, KOLHAPUR – 416004

(An Autonomous Institute of Govt. Of Maharashtra)

SUMMER 2024

EXAM SEAT NO.

LEVEL : - **Third**

PROGRAM : **Civil Engineering**

COURSE CODE : **CEG305/CEF305**

COURSE NAME : **Soil Mechanics and Foundation Engineering**

MAX. MARKS : **80** TIME : **3 HRS.** DATE :- **15 May 2024**

Instruction :-

- 1) Answers must be written in the main answer book provided (and supplements if required).
- 2) Illustrate your answers with sketches wherever necessary.
- 3) Use of non-programmable pocket calculator is permissible.
- 4) Mathematical and other tables shall be made available on request.
- 5) Assume and mention suitable additional data if necessary.
- 6) Use of Mobile is strictly prohibited.
- 7) QN- Question No., SQN-Sub Question No. R- Remembering, U- Understanding, A- Application.

QN	S Q N	Question Text	R/ U/ A	CO	Mar ks
Q.1		Attempt any FOUR :			08
	a)	Define soil as per engineering view.	R	1	
	b)	Draw phase diagram for i) 100% saturated soil ii) 0 % saturated soil	U	1	
	c)	Define void ratio and porosity.	R	1	
	d)	A soil sample has porosity 25% and sp gravity 2.67. Calculate void ratio and dry density.	A	1	
	e)	Define co-efficient of permeability of soil and state its unit.	R	2	
	f)	Enlist any four field situations where compaction of soil is required.	R	3	
Q.2		Attempt any FOUR :			16
	a)	Define liquid limit and plastic limit.	R	1	
	b)	Draw a neat diagram of casagrande's apparatus of liquid with labeling.	U	1	
	c)	A saturated soil mass has a volume of 20cm^3 at its liquid state. If water content at shrinkage is 42% and liquid limit is 17% , $G= 2.74$, find minimum volume which soil can attain.	A	1	
	d)	Explain the falling head method for determination of coefficient of permeability with respect to i) diagram of apparatus set up with labeling. ii) Formula with meaning of each term iii) Procedure iv) application of test	U	2	
	e)	Draw a neat labeled diagram of modified proctor apparatus.	U	2	
	f)	Enlist any four methods used to determine the shear strength of soil and its use as per type of soil.	R	3	

P. T. O.

Q.3	Attempt any FOUR:					16															
	a)	Explain particle size classification of soil.	U	1																	
	b)	Specific gravity of soil was tested in laboratory. Results are as follows . Find specific gravity of that soil.	A	1																	
		<table border="1"> <thead> <tr> <th>Sr. No</th> <th>determination</th> <th>Reading in gms</th> </tr> </thead> <tbody> <tr> <td>1</td> <td>Mass of pycnometer</td> <td>652</td> </tr> <tr> <td>2</td> <td>Mass of pycnometer + soil</td> <td>918</td> </tr> <tr> <td>3</td> <td>Mass of pycnometer + soil + water</td> <td>1640</td> </tr> <tr> <td>4</td> <td>Mass of pycnometer + water</td> <td>1470</td> </tr> </tbody> </table>	Sr. No	determination	Reading in gms	1	Mass of pycnometer	652	2	Mass of pycnometer + soil	918	3	Mass of pycnometer + soil + water	1640	4	Mass of pycnometer + water	1470				
Sr. No	determination	Reading in gms																			
1	Mass of pycnometer	652																			
2	Mass of pycnometer + soil	918																			
3	Mass of pycnometer + soil + water	1640																			
4	Mass of pycnometer + water	1470																			
	c)	A sample of soil was tested in constant head per meameter. The length of sample was 20cm , the diameter of per meameter is 5 cm under the 40cm . Discharge found to be 150cc in 10min then calculate coefficient of permeability.	A	2																	
	d)	Enlist four field situations where shear failure of soil occurs	R	3																	
	e)	Explain procedure of preparation of specimen used for determination of California bearing ratio.	U	3																	
	f)	State the effect of water content on the compaction of soil.	R	3																	
Q.4	Attempt any FOUR:					08															
	a)	State any four field applications for Earth pressure study.	R	4																	
	b)	Define disturbed & undisturbed soil sample.	R	4																	
	c)	Enlist any four types of machine foundation.	R	6																	
	d)	Define safe bearing capacity & ultimate bearing capacity of soil.	R	5																	
	e)	State any two protection measures for sheet pile corrosion.	R	5																	
	f)	Enlist any four factors deciding depth of foundation.	U	5																	
Q.5	Attempt any FOUR :					16															
	a)	State the necessity of site investigation.	R	4																	
	b)	Explain classification of pile & explain any one in details	U	5																	
	c)	Why combined footing is necessary .	R	5																	
	d)	Explain how depth of foundation affect bearing capacity.	U	5																	
	e)	Explain standard penetration test procedure.	U	5																	
	f)	Enlist any four soil support methods while excavation & explain any one detail.	U	6																	
Q.6	Attempt any FOUR:					16															
	a)	State type of earth retaining structure. Explain any one in detail.	R	4																	
	b)	Explain stability consideration for earth retaining structure.	U	4																	
	c)	Sketch open well foundation with all details.	A	5																	
	d)	Explain effect of water table on bearing capacity.	U	5																	
	e)	Explain why vibration isolation is required in machine foundation.	U	6																	
	f)	Explain different dewatering method . Explain any one in detail.	U	6																	

GOVERNMENT POLYTECHNIC, KOLHAPUR – 416004.

(An Autonomous Institute of Govt. Of Maharashtra)

EVEN TERM END EXAM SUMMER -2024**EXAM SEAT NO.**

--	--	--	--	--	--

LEVEL :- **THIRD**PROGRAM : **CIVIL ENGINEERING**COURSE CODE :- **CEG310/CEF310**COURSE NAME **TRANSPORTATION ENGINEERING**MAX. MARKS : **80** TIME : **03Hrs.**DATE :- **14/05/2024**

Instruction :-

- 1) Answers must be written in the main answer book provided.(and supplements if required)
- 2) Illustrate your answers with sketches wherever necessary.
- 3) Use of non-programmable pocket calculator is permissible.
- 4) Mathematical and other tables shall be made available on request.
- 5) Assume and mention suitable additional data if necessary.
- 6) Use of Mobile is strictly prohibited.
- 7) QN- Question No., SQN-Sub Question No. R- Remembering, U- Understanding, A- Application.

QN	S Q N	Question Text	R/ U/ A	Co CEG 310	Mar ks
Q.1		Attempt any FOUR :			08
	a)	State the importance of Road transportation in the overall development of country. (any four)	U	1	
	b)	Define :- i) Ruling Gradient ii) Exceptional Gradient.	R	1	
	c)	Write any four advantages and disadvantages of concrete roads.	U	2	
	d)	State the suitability of Road Tar i.e. RT2 & RT3 as per Indian standard.	A	2	
	e)	State any four advantages and disadvantages of Tunnels.	U	3	
	f)	State any four purpose of providing shafts in tunnels.	U	3	
Q.2		Attempt any FOUR :			16
	a)	Draw a neat labeled sketch of c/s of National Highway in cutting showing clearly landwidth, formation width, pavement width, locations of drains, spoil bank etc. with proper dimensions.	A	1	
	b)	i) What do you understand by traffic volume study?	R? U	1	
		ii) State any six objectives of traffic volume study.	U	1	
	c)	Draw a neat labeled sketch showing all component parts of flexible pavement and write the function of all component parts.	A	2	
	d)	Explain with a neat sketch the procedure of transferring the alignment to inside of the tunnel.	A	3	
	e)	Draw following shapes of tunnel and write its suitability i) Egg. Type shape tunnel. ii) Segmental type tunnel iii) Box type shape iv) Horse-shoe shape	A	3	
	f)	Briefly describe the construction of tunnel through soft rock by shield method with a neat sketch.	A	3	
Q.3		Attempt any FOUR :			16
	a)	i) State the meaning of superelevation with a neat sketch.	R/ U	1	
		ii) State any four objects of providing superelevation to the road pavement.	A	1	
	b)	Give the gradients as per IRC recommendations for the followings i) Minimum gradient in plain road. ii) Maximum gradient in hill roads. iii) Ruling gradient in hill roads. iv) Exceptional gradient in hill roads.	A	1	

P.T.O

	c)	Discuss in brief construction procedure of bituminous concrete road. Write materials required for construction of this road.	A	2	
	d)	Explain with a sketch the construction procedure of concrete road by alternate bay method.	A	2	
	e)	Describe how the alignment of tunnel is transferring to inside of tunnel. Explain with a neat sketch.	A	3	
	f)	i) State any four purpose of lining of tunnel. ii) Write any four factors affecting the type of lining.	R U	3 3	
QN	S Q N	SECTION -II	R/ U/ A	Co	Ma rks
Q.4		Attempt any FOUR :			08
	a)	State the meaning of fixtures and fastenings of rails.	U	4	
	b)	Draw a neat labeled sketch of flat footed rail with dimension.	A	4	
	c)	State any 4 purposes of providing railway station.	U	5	
	d)	Define 'points and crossings'.	R	5	
	e)	Enlist the classification of bridges according to purpose.	R	6	
	f)	Define 'Bridge alignment'. State any two factors affecting on it.	R/ U	6	
Q.5		Attempt any FOUR :			16
	a)	Define creep of rail. State any six causes of creep of rail.	U	4	
	b)	State any four requirements of ideal permanent way of railway.	R	4	
	c)	Illustrate the neat sketch of layout of wayside station showing the double line track and write its necessary.	A	5	
	d)	State the main requirements of locomotive yard.	U	5	
	e)	Explain meaning and suitability of i) Fixed bearing and ii) Expansion bearing.	A	6	
	f)	Define the abutments. Give their types.	U	6	
Q.6		Attempt any FOUR :			16
	a)	State any eight functions of ballast.	R	4	
	b)	Define sleeper density. State the factors on which it depends.	R	4	
	c)	Define i) wing rail ii) check rail iii) tongue rail iv) nose of crossings.	R	5	
	d)	Draw a neat labeled sketch of any two rail fixtures and fastenings.	A	4	
	e)	State the various types of crossings and explain any one.	U	5	
	f)	Classify the bridge according to span length, purpose, alignment and according to level of bridge floor.	R	6	

GOVERNMENT POLYTECHNIC, KOLHAPUR – 416004.

(An Autonomous Institute of Govt. Of Maharashtra)

EVEN TERM END EXAM SUMMER -2024**EXAM SEAT NO.**

--	--	--	--	--	--

LEVEL :- **THIRD**PROGRAM : **CIVIL ENGINEERING**COURSE CODE :- **CEG310/CEF310**COURSE NAME **TRANSPORTATION ENGINEERING**MAX. MARKS : **80** TIME : **03Hrs.**DATE :- **14/05/2024**

Instruction :-

- 1) Answers must be written in the main answer book provided.(and supplements if required)
- 2) Illustrate your answers with sketches wherever necessary.
- 3) Use of non-programmable pocket calculator is permissible.
- 4) Mathematical and other tables shall be made available on request.
- 5) Assume and mention suitable additional data if necessary.
- 6) Use of Mobile is strictly prohibited.
- 7) QN- Question No., SQN-Sub Question No. R- Remembering, U- Understanding, A- Application.

QN	S Q N	Question Text	R/ U/ A	Co CEG 310	Mar ks
Q.1		Attempt any FOUR :			08
	a)	State the importance of Road transportation in the overall development of country. (any four)	U	1	
	b)	Define :- i) Ruling Gradient ii) Exceptional Gradient.	R	1	
	c)	Write any four advantages and disadvantages of concrete roads.	U	2	
	d)	State the suitability of Road Tar i.e. RT2 & RT3 as per Indian standard.	A	2	
	e)	State any four advantages and disadvantages of Tunnels.	U	3	
	f)	State any four purpose of providing shafts in tunnels.	U	3	
Q.2		Attempt any FOUR :			16
	a)	Draw a neat labeled sketch of c/s of National Highway in cutting showing clearly landwidth, formation width, pavement width, locations of drains, spoil bank etc. with proper dimensions.	A	1	
	b)	i) What do you understand by traffic volume study?	R? U	1	
		ii) State any six objectives of traffic volume study.	U	1	
	c)	Draw a neat labeled sketch showing all component parts of flexible pavement and write the function of all component parts.	A	2	
	d)	Explain with a neat sketch the procedure of transferring the alignment to inside of the tunnel.	A	3	
	e)	Draw following shapes of tunnel and write its suitability i) Egg. Type shape tunnel. ii) Segmental type tunnel iii) Box type shape iv) Horse-shoe shape	A	3	
	f)	Briefly describe the construction of tunnel through soft rock by shield method with a neat sketch.	A	3	
Q.3		Attempt any FOUR :			16
	a)	i) State the meaning of superelevation with a neat sketch.	R/ U	1	
		ii) State any four objects of providing superelevation to the road pavement.	A	1	
	b)	Give the gradients as per IRC recommendations for the followings i) Minimum gradient in plain road. ii) Maximum gradient in hill roads. iii) Ruling gradient in hill roads. iv) Exceptional gradient in hill roads.	A	1	

P.T.O

	c)	Discuss in brief construction procedure of bituminous concrete road. Write materials required for construction of this road.	A	2		
	d)	Explain with a sketch the construction procedure of concrete road by alternate bay method.	A	2		
	e)	Describe how the alignment of tunnel is transferring to inside of tunnel. Explain with a neat sketch.	A	3		
	f)	i) State any four purpose of lining of tunnel. ii) Write any four factors affecting the type of lining.	R U	3 3		
QN	S Q N	SECTION -II			R/ U/ A	Co Ma rks
Q.4		Attempt any FOUR:			08	
	a)	State the meaning of fixtures and fastenings of rails.	U	4		
	b)	Draw a neat labeled sketch of flat footed rail with dimension.	A	4		
	c)	State any 4 purposes of providing railway station.	U	5		
	d)	Define 'points and crossings'.	R	5		
	e)	Enlist the classification of bridges according to purpose.	R	6		
	f)	Define 'Bridge alignment'. State any two factors affecting on it.	R/ U	6		
Q.5		Attempt any FOUR:			16	
	a)	Define creep of rail. State any six causes of creep of rail.	U	4		
	b)	State any four requirements of ideal permanent way of railway.	R	4		
	c)	Illustrate the neat sketch of layout of wayside station showing the double line track and write its necessary.	A	5		
	d)	State the main requirements of locomotive yard.	U	5		
	e)	Explain meaning and suitability of i) Fixed bearing and ii) Expansion bearing.	A	6		
	f)	Define the abutments. Give their types.	U	6		
Q.6		Attempt any FOUR:			16	
	a)	State any eight functions of ballast.	R	4		
	b)	Define sleeper density. State the factors on which it depends.	R	4		
	c)	Define i) wing rail ii) check rail iii) tongue rail iv) nose of crossings.	R	5		
	d)	Draw a neat labeled sketch of any two rail fixtures and fastenings.	A	4		
	e)	State the various types of crossings and explain any one.	U	5		
	f)	Classify the bridge according to span length, purpose, alignment and according to level of bridge floor.	R	6		

GOVERNMENT POLYTECHNIC, KOLHAPUR – 416004.

(An Autonomous Institute of Govt. Of Maharashtra)

SUMMER- 2024

EXAM SEAT NO.

LEVEL : - Fourth

PROGRAM : Civil Engineering

COURSE CODE :- CEG 402/ CEF402

COURSE NAME :- Design and Drafting of R.C.C.Structures

MAX. MARKS : 80 TIME : 04 Hrs DATE :- 14/5/2024

QN	S Q N	SECTION -II	R/ U/ A	Co CEG 402	Ma rks												
Q.4		Attempt any FOUR: (2x4=08)			08												
	a)	State any two type of shear reinforcement	R	4													
	b)	State any two IS 456-2000 provisions for serviceability limit state for beams/slabs.	R	4													
	c)	State criteria for one way slab and two way slab design.	R	5													
	d)	State reasons for no distribution steel in two way slab?	R	5													
	e)	State the functions of transverse reinforcement in a column?	R	6													
	f)	State the critical section for one way shear and two way shear in footing	R	6													
Q.5		Attempt any Two : (2x8=16)			16												
	a)	1) State the condition for minimum shear reinforcement and spacing provided with meaning of each term. 2) Determine the development length of 16 mm diameter Fe 415 bar in compression if design bond stress is 1.4 N/ mm ² for plain bar in tension.	A	4													
	b)	A Beam 230mm x 560 mm effective reinforced with ^{u ley} 6 bars 25 mm diameter , effective span is 8 m and loaded with 25kN/m. Desgin shear reinforcement for beam. Take M20 concrete and Fe415 steel Use following table <table border="1" style="width:100%; margin-top: 5px;"> <tr> <td>% Pt</td> <td>1.0</td> <td>1.25</td> <td>1.5</td> <td>1.75</td> <td>2.0</td> </tr> <tr> <td>Tc N/mm²</td> <td>0.6</td> <td>0.64</td> <td>0.68</td> <td>0.71</td> <td>0.70</td> </tr> </table>	% Pt	1.0	1.25	1.5	1.75	2.0	Tc N/mm ²	0.6	0.64	0.68	0.71	0.70	A	4	
% Pt	1.0	1.25	1.5	1.75	2.0												
Tc N/mm ²	0.6	0.64	0.68	0.71	0.70												
	c)	1) Calculate the shear resisted by two bend up bars of 20 mm diameter of Fe 415 take angle $\alpha = 45^\circ$ 2) Draw a neat sketch of reinforcement details of one way continuous slab	A	4/													
Q.6		Attempt any Two : (2x8=16)			16												
	a)	1) Draw detailed diagram showing reinforcement details in case of dog legged stair case 2) Write IS specification for minimum eccentricity and transverse reinforcement of an axially loaded column.	U	5/													
	b)	Design a simply supported slab over a passage of effective span 3.2 m by using M25 concrete and Fe 415 steel. Assume super imposed load including floor finish as 3 kN/m ² and M.F.=1.4 Sketch the cross section.	A	5													
	c)	Design the isolated square footing for a square column section 400 mm x 400 mm size. Safe bearing capacity of soil= 250 kN/m ² , Load on the column=1000 kN. Concrete M20 and Steel Fe 415 used . Calculate depth of footing from bending moment criteria. No shear check is required. Draw reinforcement diagram	A	6													

GOVERNMENT POLYTECHNIC, KOLHAPUR – 416004.

(An Autonomous Institute of Govt. Of Maharashtra)

SUMMER- 2024**EXAM SEAT NO.**

--	--	--	--	--	--

LEVEL : FOURTH

PROGRAM : CIVIL ENGINEERING

COURSE CODE :- CEG402 / CEF402

COURSE NAME :- DESIGN & DRAFTING OF RCC STRUCTURE

MAX. MARKS : 80 TIME : 04 Hrs DATE :- 14/ 5/ 2024

Instruction :-

- 1) Answers of two sections must be written in separate section answer book provided.
- 2) Illustrate your answers with sketches wherever necessary.
- 3) Use of non-programmable pocket calculator is permissible.
- 4) Mathematical and other tables shall be made available on request.
- 5) Assume and mention suitable additional data if necessary.
- 6) Use of Mobile is strictly prohibited.
- 7) QN- Question No., SQN-Sub Question No. R- Remembering, U- Understanding, A- Application.

QN	S Q N	SECTION -I	R/ U/ A	Co	Ma rks
Q.1		Attempt any FOUR :			08
	a)	Define limit state of serviceability with an example.	R	1	2
	b)	Comment on Prestressed Concrete and quote a field application.	U	1	2
	c)	Draw the reinforcement detailing in circular water tank.	U	1	2
	d)	State the conditions of minimum and maximum steel in beam.	R	2	2
	e)	State the code numbers for respective loads considered.	U	2	2
	f)	Comment on predictions/simulations used in structural softwares.	R	1	2
Q.2		Attempt any FOUR :			16
	a)	State the assumptions made in Limit state of Collapse-flexure..	U	2	
	b)	Find the Ultimate Moment of Resistance of a RC beam 300mm wide and 450mm deep to the centre of 4 -20 mm bars in the tension zone having grade Fe415 in concrete M20.	A	2	
	c)	Write the expressions for the effective flange width of L beam and L beams cast integrally with slab with 60 % of slab steel spanning across the beam span.	U	3	
	d)	Draw the strain and stress block diagram for doubly reinforced section.	U	2	
	e)	Draw the sketch of seismic detailing of Column and footing joint as per IS 13920	U	1	
	f)	Draw the Retaining wall and label the types of steel .Also draw the pressure distribution diagram.	U	1	
Q.3		Attempt any TWO :			16
	a)	i)State the effective depth calculations for various types of support conditions for beams and slabs.	U	2	
		ii)Explain Modification factor and its role in design of flexure sections.	U	3	
	b)	Find the Ultimate Moment of resistance of doubly reinforced steel section carrying 4- 16 Tor in compression zone and 4-20 tor in tension with covers 40mm on either side, b=230mm, d =400mm cast in M20 concrete and Fe415 steel.Take the stress in steel in compression as 353 MPa.	A	2	
	c)	Calculate ultimate moment of resistance of T beam having flange width 1200 mm, depth of slab 140 mm, effective depth of beam 450 mm, width of web 250 mm. It is reinforced with 4 bars of 20 mm dia. and 415 grade steel. Assume M20 grade concrete.	A	3	

GOVERNMENT POLYTECHNIC, KOLHAPUR – 416004.

(An Autonomous Institute of Govt. Of Maharashtra)

SUMMER 2024**EXAM SEAT NO.**

--	--	--	--	--	--

LEVEL : - FOURTH

PROGRAM : CIVIL ENGINEERING

COURSE CODE :- CEG409/CEF410.

COURSE NAME :- TOWN AND COUNTRY PLANNING

MAX. MARKS : 80 TIME : 03 Hrs

DATE :- 13/5/2024

Instruction :-

- 1) Answers of two sections must be written in separate section answer book provided.
- 2) Illustrate your answers with sketches wherever necessary.
- 3) Use of non-programmable pocket calculator is permissible.
- 4) Mathematical and other tables shall be made available on request.
- 5) Assume and mention suitable additional data if necessary.
- 6) Use of Mobile is strictly prohibited.
- 7) QN- Question No., SQN-Sub Question No. R- Remembering, U- Understanding, A- Application.

QN	S Q N	SECTION -I	R/ U/ A	Co	Ma rks
Q.1		Attempt any FOUR :			08
	a)	State the principles of neighbourhood planning.	U	CEG409-3	
	b)	Draw a neat sketch with the label of ribbon development.	A	CEG 409-1	
	c)	Define the zoning and any two types of zone.	R	CEG 409-1	
	d)	State any four classification of public buildings.	R	CEG409-2	
	e)	Write the evolution of town planning.	U	CEG 409-1	
	f)	Define a master plan and mention it's any two objects.	R	CEG409-2	
Q.2		Attempt any FOUR :			16
	a)	Explain in details the forms of planning? Enlist any four forms of planning.	A	CEG409-2	
	b)	Explain five year plan of town and country planning.	U	CEG 409-1	
	c)	Explain in brief the features of neighbourhood planning.	U	CEG409-3	
	d)	State any eight factors to be considered for selecting site for industries.	R	CEG409-2	
	e)	Explain the landscape design with its purposes.	U	CEG409-2	
	f)	Explain any four the importance of neighbourhood planning.	U	CEG409-3	
Q.3		Attempt any FOUR :			16
	a)	State any eight causes of formation of slums in India.	U	CEG409-2	
	b)	Describe any four objects of town planning.	R	CEG 409-1	
	c)	Explain any two types of recreation systems in details.	U	CEG409-2	
	d)	State and describe the importance of co-operative housing societies.	U	CEG409-3	
	e)	Explain any four housing problems in India.	U	CEG409-2	
	f)	Enlist any eight type of information collected in social survey.	R	CEG 409-1	

P.T.O.

GOVERNMENT POLYTECHNIC, KOLHAPUR – 416004.

(An Autonomous Institute of Govt. Of Maharashtra)

SUMMER 2024**EXAM SEAT NO.**

--	--	--	--	--	--

LEVEL :- IV

PROGRAM : CIVIL ENGINEERING

COURSE CODE :- CEG 409/ CEF410

COURSE NAME :- Town & Country Planning.

MAX. MARKS : 80 TIME : 03 Hrs

DATE :- 13/5/2024

QN	S Q N	SECTION –II	R/ U / A	Co	Marks
Q.4		Attempt any FOUR :			08
	a)	State the necessity of planning law and legislation.	U	CEG 409-4	
	b)	State any two legislations used for development and control of urban land.	R	CEG 409-4	
	c)	Define Set Back.	R	CEG 409-5	
	d)	State any two circumstances in which building bye laws are applicable.	U	CEG 409-5	
	e)	State necessity of Village Planning.	U	CEG 409-6	
	f)	Define agro industries.	R	CEG 409-6	
Q.5		Attempt any FOUR :			16
	a)	Explain aims of land acquisition act.	U	CEG 409-4	
	b)	Explain the functions of Zilla Parishad.	U	CEG 409-4	
	c)	Explain importance of Bye laws.	R	CEG 409-5	
	d)	Explain the concept of light plane with neat sketch.	A	CEG 409-5	
	e)	Differentiate between rural and urban areas.	A	CEG 409-6	
	f)	Explain any four principles of village planning in brief.	R	CEG 409-6	
Q.6		Attempt any FOUR :			16
	a)	Explain the frame work of municipal corporation.	R	CEG 409-4	
	b)	State any four categories of MR & TP act. Explain any one in detail.	U	CEG 409-4	
	c)	Give the provision for off-street parking for cars in case of i) Colleges ii) Secondary School iii) Cinema Theater iv) Hospital	A	CEG 409-5	
	d)	Explain Floor Space Index with suitable example.	A	CEG 409-5	
	e)	Explain rural housing problem in India.	U	CEG 409-6	
	f)	Explain low cost housing.	U	CEG 409-6	

GOVERNMENT POLYTECHNIC, KOLHAPUR – 416004.

(An Autonomous Institute of Govt. Of Maharashtra)

EVEN TERM END EXAM SUMMER -2024**EXAM SEAT NO.**

--	--	--	--	--	--

LEVEL :- **THIRD**PROGRAM : **CIVIL ENGINEERING**COURSE CODE :- **CEG309/CEF309**COURSE NAME **SURVEYING - II**MAX. MARKS : **80** TIME : **03Hrs.**DATE :- **13/05/2024**

Instruction :-

- 1) Answers must be written in the main answer book provided.(and supplements if required)
- 2) Illustrate your answers with sketches wherever necessary.
- 3) Use of non-programmable pocket calculator is permissible.
- 4) Mathematical and other tables shall be made available on request.
- 5) Assume and mention suitable additional data if necessary.
- 6) Use of Mobile is strictly prohibited.
- 7) QN- Question No., SQN-Sub Question No. R- Remembering, U- Understanding, A- Application.

QN	S Q N	Question Text	R/ U/ A	Co CEG 309	Mar ks												
Q.1		Attempt any FOUR :			08												
	a)	State any four uses of transit theodolite.	U	1													
	b)	Define i) Face right ii) Vertical axis.	R	1													
	c)	What is meant by analytic lens? Where it is provided?	U	2													
	d)	Define deflection angle with sketch.	U	1													
	e)	Define Transiting and swinging.	R	1													
	f)	Define i) Line of collimation ii) Axis of Telescope.	R	1													
Q.2		Attempt any FOUR :			16												
	a)	State the procedure of measuring horizontal angle by transit.	U	1													
	b)	Following are the interior angles of a closed traverse ABCDE $\angle A = 87^{\circ} 50' 20''$, $\angle B = 114^{\circ} 55' 40''$, $\angle C = 94^{\circ} 38' 50''$, $\angle D = 129^{\circ} 40' 40''$, $\angle E = 112^{\circ} 54' 30''$ if the bearing of AB is $221^{\circ} 18' 40''$. Calculate the bearings of the remaining sides.	A	1													
	c)	Following are the length and bearings of traverse ABCD <table border="1" data-bbox="289 1684 919 1901"><thead><tr><th>Line</th><th>Length (m)</th><th>Bearing</th></tr></thead><tbody><tr><td>AB</td><td>258.00</td><td>30°</td></tr><tr><td>BC</td><td>321.00</td><td>140°</td></tr><tr><td>CD</td><td>180.00</td><td>210°</td></tr></tbody></table> Calculate the length and bearing of line DA.	Line	Length (m)	Bearing	AB	258.00	30°	BC	321.00	140°	CD	180.00	210°	A	1	
Line	Length (m)	Bearing															
AB	258.00	30°															
BC	321.00	140°															
CD	180.00	210°															
	d)	Explain in brief procedure to determine tachometric constant in field.	A	2													
	e)	State the procedure of using Theodolite as Tachometer.	U	2													
	f)	State 'Bowditch' Rule. Where it is applicable.	U	1													
Q.3		Attempt any FOUR :			16												
	a)	Define closing error. How it is balanced graphically.	R	1													
	b)	State the sources of errors in Theodolite surveying and explain any one.	U	1													
	c)	Describe the procedure of measuring bearing of a line.	U	1													

P.T.O

	d)	The co-ordinates of two points C and D are as following	A	1														
		<table border="1"> <thead> <tr> <th rowspan="2">Point</th> <th colspan="2">Co-ordinates</th> </tr> <tr> <th>N</th> <th>E</th> </tr> </thead> <tbody> <tr> <td>C</td> <td>982.50</td> <td>825.20</td> </tr> <tr> <td>D</td> <td>1198.60</td> <td>576.40</td> </tr> </tbody> </table>	Point	Co-ordinates		N	E	C	982.50	825.20	D	1198.60	576.40					
Point	Co-ordinates																	
	N	E																
C	982.50	825.20																
D	1198.60	576.40																
		Find the Length and bearing of CD.																
	e)	A tachometer was set up at a station 'P' and the following readings were obtained on a vertically held staff.	A	2														
		<table border="1"> <thead> <tr> <th>Station</th> <th>Staff Station</th> <th>Vertical Angle</th> <th>Hair readings</th> <th>Remarks</th> </tr> </thead> <tbody> <tr> <td rowspan="2">P</td> <td>BM</td> <td>$-6^{\circ}15'$</td> <td>1.030, 1.110, 1.150</td> <td rowspan="2">RL of BM= 500.300m</td> </tr> <tr> <td>Q</td> <td>$+12^{\circ}30'$</td> <td>0.945, 1.065, 1.175</td> </tr> </tbody> </table>	Station	Staff Station	Vertical Angle	Hair readings	Remarks	P	BM	$-6^{\circ}15'$	1.030, 1.110, 1.150	RL of BM= 500.300m	Q	$+12^{\circ}30'$	0.945, 1.065, 1.175			
Station	Staff Station	Vertical Angle	Hair readings	Remarks														
P	BM	$-6^{\circ}15'$	1.030, 1.110, 1.150	RL of BM= 500.300m														
	Q	$+12^{\circ}30'$	0.945, 1.065, 1.175															
		The constants of the instrument were 100 & 0.2. Find horizontal distance from P to Q and reduced level of Q.																
	f)	State any four essential characteristics of Tachometer.	U	2														
Q.4		Attempt any FOUR :			08													
	a)	State various situations where plane table survey is used.	U	3														
	b)	Define Horizontal curve and vertical curve.	R	4														
	c)	State any four advantages of total station over dumpy level and theodolite.	U	5														
	d)	State the object of remote sensing.	R	6														
	e)	State the purpose of alidade and U fork in plane table surveying.	A	3														
	f)	State the expression for length of curve with meaning of terms used.	A	4														
Q.5		Attempt any FOUR :			16													
	a)	Define orientation and explain orientation by magnetic needle with sketch.	U	3														
	b)	Explain with sketch radiation method of plane table surveying.	A	3														
	c)	Calculate the ordinates from long chord to set a circular curve at 10m interval given that the length of long chord is 60m and radius of curve is 180m.	A	4														
	d)	State the nomenclature of curve and give relation between degree of curve and its radius.	A	4														
	e)	State any four component parts of digital theodolite and state their purpose.	R	5														
	f)	Give any eight applications of remote sensing.	A	6														
Q.6		Attempt any FOUR :			16													
	a)	State any four advantages and disadvantages of plane table surveying.	R	3.														
	b)	Compare radiation and intersection methods of plane table surveying.	A	3														
	c)	Explain with sketch notations used in simple curve.	A	4														
	d)	Explain the procedure of layout using total station.	U	5														
	e)	Describe the procedure for setup of total station.	U	5														
	f)	State advantages and disadvantages of GPS.	A	6														

GOVERNMENT POLYTECHNIC, KOLHAPUR – 416004.

(An Autonomous Institute of Govt. Of Maharashtra)

SUMMER- 2024

EXAM SEAT NO.

--	--	--	--	--	--

LEVEL :- THREE

PROGRAM : CIVIL ENGINEERING

COURSE CODE :- CEG302/CEF302

COURSE NAME :- BUILDING CONSTRUCTION

MAX. MARKS : 80 TIME : 03 Hrs DATE :- 11/5/2024

Instruction :-

- 1) Answers of two sections must be written in separate section answer book provided.
- 2) Illustrate your answers with sketches wherever necessary.
- 3) Use of non-programmable pocket calculator is permissible.
- 4) Mathematical and other tables shall be made available on request.
- 5) Assume and mention suitable additional data if necessary.
- 6) Use of Mobile is strictly prohibited.
- 7) QN- Question No., SQN-Sub Question No. R- Remembering, U- Understanding, A- Application.

QN	S Q N	Question Text	R/ U/ A	Co	Ma rks
Q.1		Attempt any FOUR :			08
	a)	Write any two functions of Lintel.	R	1	
	b)	Enlist any two classifications of Rocks.	U	1	
	c)	What are Fly Ash bricks?	R	1	
	d)	Define foundation.	R	2	
	e)	Write any two classifications of Stone Masonry.	R	2	
	f)	What is the purpose Scaffolding?	U	2	
Q.2		Attempt any FOUR :			16
	a)	Give any four differences between Framed and Load Bearing structures.	U	1	
	b)	Explain in detail preparation of Layout Plan	U	2	
	c)	Explain Hollow Block masonry and Composite masonry	U	2	
	d)	Draw neat sketches of any two Shallow Foundations.	R	2	
	e)	Explain the component parts of scaffolding	U	2	
	f)	Draw neat labeled sketch of Single Paneled door.	U	3	
Q.3		Attempt any FOUR :			16
	a)	What are the functions of cement mortar, also enlist various Defects in timber	A	1	
	b)	Enlist various Tools and Plants used for excavation	A	2	
	c)	What is Frog in brick, also draw the sketch of Queen Closure	A	2	
	d)	Explain in detail Flemish bond.	A	2	
	e)	When pile foundations are provided. Also state requirements of Good Foundations.	A	2	
	f)	Draw the sketch of Louvered window, and also give its suitability	A	3	

P.T.O.

GOVERNMENT POLYTECHNIC, KOLHAPUR – 416004.

(An Autonomous Institute of Govt. SOF Maharashtra)

SUMMER- 2024

EXAM SEAT NO.

--	--	--	--	--	--

LEVEL :- THREE

PROGRAM : CIVIL ENGINEERING

COURSE CODE :- CEG 302 / CEF302

COURSE NAME :- BUILDING CONSTRUCTION

MAX. MARKS : 80

TIME : 03 Hrs

DATE :- 11/5/24

Instruction :-

- 1) Answers of two sections must be written in separate section answer book provided.
- 2) Illustrate your answers with sketches wherever necessary.
- 3) Use of non-programmable pocket calculator is permissible.
- 4) Mathematical and other tables shall be made available on request.
- 5) Assume and mention suitable additional data if necessary.
- 6) Use of Mobile is strictly prohibited.
- 7) QN- Question No., SQN-Sub Question No. R- Remembering, U- Understanding, A - Application.

QN	S Q N	Question Text	R/ U/ A	CO CEG 302	Ma rks
Q.4		Attempt any FOUR :			08
	a)	Give any two thumb rules used in deciding rise and tread combination.	R	04	
	b)	State the suitability of i) Lift ii) Ramp	U	04	
	c)	Enlist any four materials used for roof coverings.	R	05	
	d)	Define Dado.	R	05	
	e)	Give the formwork stripping time for: i) Props to Slab over 4.5m. ii) Beam soffits	R	06	
	f)	State the use of epoxy resins.	U	06	
Q.5		Attempt any FOUR :			16
	a)	State the points to be kept in mind while planning a staircase.	U	04	
	b)	Explain with reasons what type of floor finishing will be required for (i) Operation theatre (ii) Dancing Hall (iii) Library (iv) Hostel.	A	05	
	c)	Explain requirements of good roof.	R	05	
	d)	Explain any two types of external plaster finishes.	R	05	
	e)	Draw a neat labeled sketch of wooden form work for beam.	A	06	
	f)	Explain termite proofing with its necessity and importance.	U	06	
Q.6		Attempt any FOUR :			16
	a)	Draw a labeled sketch (plan) of quarter turn stair and dog-legged stair.	A	04	
	b)	Describe in detail procedure of pointing.	R	05	
	c)	State any eight characteristics of ideal paint.	R	05	
	d)	Describe the procedure of water proofing for sanitary block.	U	06	
	e)	Explain any four causes of cracks in building.	U	06	
	f)	Give requirements of good formwork.	R	06	

GOVERNMENT POLYTECHNIC, KOLHAPUR – 416004.

(An Autonomous Institute of Govt. Of Maharashtra)

SUMMER- 2024

EXAM SEAT NO.

--	--	--	--	--	--

LEVEL :- V

PROGRAM : Civil Engineering

COURSE CODE :- CEG 509

COURSE NAME :- SOLID WASTE MANAGEMENT

MAX. MARKS : 80 TIME : 03 Hrs DATE :- 10/5/2024

Instruction :-

- 1) Answers of two sections must be written in separate section answer book provided.
- 2) Illustrate your answers with sketches wherever necessary.
- 3) Use of non-programmable pocket calculator is permissible.
- 4) Mathematical and other tables shall be made available on request.
- 5) Assume and mention suitable additional data if necessary.
- 6) Use of Mobile is strictly prohibited.
- 7) QN- Question No., SQN-Sub Question No. R- Remembering, U- Understanding, A- Application.

QN	S Q N	SECTION -I	R/ U/ A	Co CEG 509	Ma rks
Q.1		Attempt any FOUR :			08
	a)	Define Hazardous waste	R	1	
	b)	Write any two requirements of Transfer station	U	2	
	c)	Mention any two important precautions while handling Hazardous waste	U	3	
	d)	Enlist tools and equipment used in collection and transportation of solid waste	R	2	
	e)	Write any four sources of Biomedical waste	R	3	
	f)	Compare reuse and recycling of solid waste	U	2	
Q.2		Attempt any FOUR :			16
	a)	Discuss health problems arising in solid waste management	A	3	
	b)	Write importance of segregation of waste at source	A	2	
	c)	Classify colour coding for different types of Hospital waste	A	3	
	d)	Show solid waste management hierarchy with proper explanations	U	1	
	e)	Give in details importance of public involvement and participation in solid waste management	A	3	
	f)	State the meaning and necessity of Transfer station <i>Location Criteria For</i>	U	2	
Q.3		Attempt any FOUR :			16
	a)	Write various sources of solid waste and mention maximum waste generation source in Municipal solid waste	A	1	
	b)	Give classification of Hospital waste and precaution taken in transportation of these waste	A	3	
	c)	State the role of house owner and collection people in house to house collection system	A	2	
	d)	Enlist the methods of disposal of Hospital waste and explain any one in detail	U	3	
	e)	Explain organization pattern of solid waste management with neat sketch	R	2	
	f)	Enlist the factors affecting of solid waste generation and explain any two in detail	R	1	

GOVERNMENT POLYTECHNIC, KOLHAPUR – 416004.

(An Autonomous Institute of Govt. Of Maharashtra)

SUMMER- 2024**EXAM SEAT NO.**

--	--	--	--	--	--

LEVEL :- 5

PROGRAM : CIVIL ENGINEERING

COURSE CODE :- CEG509

COURSE NAME :- SOLID WASTE MANAGEMENT

MAX. MARKS : 80 TIME : 03 Hrs

DATE :- 10/5/2024

QN	S Q N	SECTION –II	R/ U/ A	CO	Ma rks
Q.4		Attempt any FOUR :			08
	a)	State any two advantages and any two disadvantages of landfilling methods.	R	4	
	b)	Enlist any four methods of pyrolysis.	U	5	
	c)	State any four roles of central pollution Control board.	U	6	
	d)	Enlist any four benefits of composting.	U	4	
	e)	Enlist any four solid waste management rules of 2016.	R	6	
	f)	State the responsibility of industry for their waste disposal. (any two)	U	5	
Q.5		Attempt any FOUR :			16
	a)	Explain the factors to be considered for site selection of sanitary landfill.	U	4	
	b)	How are the following industrial waste recycled or reused I) Paper and Pulp, II) Fly ash, III) Red Mud and IV) Blast Furnace Slag.	R	5	
	c)	Describe with a neat sketch of Dano- process of composting.	U	4	
	d)	Enlist the types of incinerators and explain any one in brief.	U	5	
	e)	Explain any 4 salient features of Plastic Waste Management Rules,2016.	U	6	
	f)	Define a leachate and Explain its control process?	U	4	
Q.6		Attempt any FOUR :			16
	a)	Enlist types of manual composting (any four) and explain any one in brief.	U	4	
	b)	Describe the legal aspects of hazardous waste management rules, 2016.	U	6	
	c)	Describe the problem of disposal of industrial waste.	U	5	
	d)	Enlist any two organic waste generated in industries and explain any one in brief.	U	5	
	e)	Describe the factors governing the composting process.	U	4	
	f)	Explain incineration with respect to need and process.	R	5	

GOVERNMENT POLYTECHNIC, KOLHAPUR – 416004.

(An Autonomous Institute of Govt. Of Maharashtra)

SUMMER 2024

EXAM. SEAT NO.

--	--	--	--	--	--

LEVEL : - FIFTH

PROGRAM : DIPLOMA IN CIVIL ENGINEERING

COURSE CODE :- CEG 504 / CEF 504

COURSE NAME :- CONTRACTS & ACCOUNTS

MAX. MARKS : 80 TIME : 03 Hrs DATE :- 9/5/2024

Instruction :-

- 1) Answers of two sections must be written in separate section answer book provided.
- 2) Illustrate your answers with sketches wherever necessary.
- 3) Use of non-programmable pocket calculator is permissible.
- 4) Mathematical and other tables shall be made available on request.
- 5) Assume and mention suitable additional data if necessary.
- 6) Use of Mobile is strictly prohibited.
- 7) QN- Question No., SQN-Sub Question No. R- Remembering, U- Understanding, A- Application.

Q.N	S Q N	SECTION –II	R/ U/ A	CO	Ma rks
Q.4		Attempt any FOUR :			08
	a)	State the meaning of- GST	R	CEG-504-4	
	b)	Enlist the types of budget	R	CEG-504-4	
	c)	State the meaning of first and final payment.	R	CEG-504-5	
	d)	Define- Accounting.	R	CEG-504-5	
	e)	Enlist the different outgoings.	R	CEG-504-6	
	f)	State any two factors affecting value of property.	R	CEG-504-6	
Q.5		Attempt any FOUR :			16
	a)	State the functions of financial management	U	CEG-504-4	
	b)	Define budget and explain in brief operating budget.	U	CEG-504-4	
	c)	State the meaning of muster roll & state the guidelines for preparing muster roll.	U	CEG-504-5	
	d)	Explain the importance of maintaining accounts in PWD.	U	CEG-504-5	
	e)	State methods of valuation and explain in brief any one.	R	CEG-504-6	
	f)	Explain the roll of valuer.	U	CEG-504-6	
Q.6		Attempt any FOUR :			16
	a)	Write the factors to be considered while preparing profit and loss sheet.	U	CEG-504-4	
	b)	State different types of payments made by PWD and explain in brief any one	U	CEG-504-5	
	c)	Enlist the methods of calculating depreciation and explain in brief straight line method.	U	CEG-504-6	
	d)	State the steps used for fixing a rent as per PWD practice.	U	CEG-504-6	
	e)	Explain capitalized value. State the method of its computation.	U	CEG-504-6	
	f)	A property fetches a monthly rent of rupees 8000 the outgoing jar As given below -sinking fund installment rupees 5000 per year, annual repair charge Rs 3000, other outgoing at 20% of gross rent. calculate capitalised value of property if rate of interest is 7%	A	CEG-504-6	

GOVERNMENT POLYTECHNIC, KOLHAPUR – 416004.

(An Autonomous Institute of Govt. Of Maharashtra)

SUMMER-2024

EXAM SEAT NO.

--	--	--	--	--	--

LEVEL :- FIFTH

PROGRAM : CIVIL ENGINEERING

COURSE CODE :- CEG504 / CEF504

COURSE NAME :- CONTRACTS AND ACCOUNTS

MAX. MARKS : 80 TIME : 03 Hrs DATE :- 09/05/2024

Instruction :-

- 1) Answers of two sections must be written in separate section answer book provided.
- 2) Illustrate your answers with sketches wherever necessary.
- 3) Use of non-programmable pocket calculator is permissible.
- 4) Mathematical and other tables shall be made available on request.
- 5) Assume and mention suitable additional data if necessary.
- 6) Use of Mobile is strictly prohibited.
- 7) QN- Question No., SQN-Sub Question No. R- Remembering, U- Understanding, A- Application.

QN	S QN	SECTION - I	R/ U/ A	Co	Marks
Q.1		Attempt any FOUR :			08
	a)	List the documents prepared for technical sanction.	R	CEG504-1	
	b)	Define major and minor work.	R	CEG504-1	
	c)	Enlist any four methods of execution of work in PWD.	R	CEG504-1	
	d)	State the meaning of Demolition Contract.	R	CEG504-2	
	e)	Define Contract.	R	CEG504-2	
	f)	State the importance of security deposit.	R	CEG504-3	
Q.2		Attempt any FOUR :			16
	a)	Explain Day work method with example.	U	CEG504-1	
	b)	State any four duties of junior engineer.	R	CEG504-1	
	c)	State the procedure for registration of contractor.	R	CEG504-2	
	d)	Classify the contractors on the basis of financial status.	R	CEG504-2	
	e)	Discuss in detail i) Unbalanced tender ii) Ring formation	U	CEG504-3	
	f)	Describe in detail two envelope method in tendering process.	U	CEG504-3	
Q.3		Attempt any FOUR :			16
	a)	Explain in detail administrative approval and technical sanction.	U	CEG504-1	
	b)	Define negotiated contract and explain its suitability.	U	CEG504-2	
	c)	Explain in brief i) cost plus percentage rate contract ii) cost plus fixed fee contract	U	CEG504-2	
	d)	Describe in detail qualities of arbitrator and power of arbitrator.	U	CEG504-2	
	e)	State the points to be included while drafting tender notice.	R	CEG504-3	
	f)	Draft a tender notice for construction of boys hostel to government polytechnic Kolhapur of estimated cost 2 crores.	A	CEG504-3	

P.T.O.

GOVERNMENT POLYTECHNIC, KOLHAPUR – 416004

(An Autonomous Institute of Govt. Of Maharashtra)

SUMMER 2024

EXAM SEAT NO.

--	--	--	--	--	--

LEVEL :- Third

PROGRAM : Civil Engineering

COURSE CODE : CEG307/CEF307

COURSE NAME : Mechanics of Structures

MAX. MARKS : 80 TIME : 3 HRS. DATE :- 09 May 2024

Instruction :-

- 1) Answers must be written in the main answer book provided (and supplements if required).
- 2) Illustrate your answers with sketches wherever necessary.
- 3) Use of non-programmable pocket calculator is permissible.
- 4) Mathematical and other tables shall be made available on request.
- 5) Assume and mention suitable additional data if necessary.
- 6) Use of Mobile is strictly prohibited.
- 7) QN- Question No., SQN-Sub Question No. R- Remembering, U- Understanding, A- Application.

QN	S Q N	Question Text	R/ U/ A	CO	Mar ks
Q.1		Attempt any FOUR:			08
	a)	State types of structural systems .	R	1	
	b)	Draw a neat labeled diagram of retaining wall.	R	1	
	c)	Define triaxial loading and give field example.	R	2	
	d)	State Hook's Law.	R	2	
	e)	Define point of contra flexure.	R	3	
	f)	Define shear force and its sign convention.	R	3	
Q.2		Attempt any FOUR:			16
	a)	Explain basic structural actions with simple pressing machine ,with the help of sketch.	U	1	
	b)	Write a short note on various materials used for civil engineering structures.	U	1	
	c)	A body undergoes two mutually perpendicular stresses 100 MPa (Compression) and 50MPa (tension) . Calculate strains along these two directions for two dimensional analysis , taking $E = 200\text{GPa}$ & $\mu = 0.3$	A	2	
	d)	A concrete column 400mm \times 300mm is reinforced with 6 bars of 16mm diameter and carries a load of 500KN. Calculate load shared by steel & concrete and also stresses developed by each material . Take modular ratio as 12	A	2	
	e)	A metal rod 24mm diameter and 2m long is subjected to an axial pull of 40KN. If the elongation of the rod is 0.5mm. Find the stresses induced and the value of Young's modulus.	A	2	
	f)	For a given material $E = 110\text{ GPa}$ modulus of rigidity $C = 43\text{GPa}$. Find the Bulk modulus (K) and Poissons ratio.	A	2	
Q.3		Attempt any FOUR:			16
	a)	A metal rod of 20mm diameter and 2.5 m long when subjected to a tensile force 70KN showed an elongation of 2.5mm and reduction in diameter 0.006mm. Calculate modulus of elasticity and Bulk modulus.	A	2	
	b)	A cantilever beam is loaded as shown in fig. 1 .Draw S.F. D. and B. M. D.	A	3	
	c)	A simply supported beam of span 7m carries a udl of 2KN/m over 4m length from left support and a point load of 5KN at 2m from right support. Draw S.F. D.	A	3	
	d)	Draw B. M. D. for Q. no. 3 (c)	A	3	
	e)	Draw SFD of a Beam as shown in Fig. 2	A	3	
	f)	Draw B. M. D. of a beam as shown in fig.2 Also find the point of contra flexure.	A	3	

P.T.O

Q.4	Attempt any FOUR :			08
	a) State parallel axis theorem with its expression.	R	4	
	b) State fluxural formula and write meaning of each term.	R	5	
	c) Define i) sectional modulus ii) Neutral axis	R	5	
	d) Define i) strain energy ii) proof resilience .	R	6	
	e) Define i) Moment of inertia ii) polar moment of inertia	R	4	
	f) Draw shear stress distribution diagram for rectangular section.	U	5	
Q.5	Attempt any FOUR :			16
	a) State any four assumption made in theory of pure bending.	R	5	
	b) Calculate polar moment of inertia of hollow circle , if external diameter of circle is 176mm and internal diameter is 132mm.	A	4	
	c) Determine I_{xx} & I_{yy} for 'T' section having horizontal flange (300×20) mm .And vertical web [180×30]mm .	A	4	
	d) Draw bending stress distribution diagram for i) I –section [symmetrical] ii) I –section [un-symmetrical]	U	5	
	e) Determine maximum stress induced in a steel flat 150mm wide × 12mm thick ,if it is bend into a circular arc of 12000mm radius. $E=2 \times 10^5 \text{ N/mm}^2$	A	5	
	f) A circular bar 20mm diameter is subjected to load 40KN. Calculate the stress induced and modulus. of resilience in the bar ,if it is 2m long and the load is applied suddenly. Take $E=2 \times 10^5 \text{ N/mm}^2$	A	6	
Q.6	Attempt any FOUR :			16
	a) Calculate moment of inertia about AB-axis of following lamina. Refer Diagram no. 1 –Section II)	A	4	
	b) A circular section of 100mm diameter is subjected to a shear force 3KN. When used as beam. Determine maximum shear stress induced and minimum shear stress. Sketch stress distribution diagram.	A	5	
	c) A simply supported beam is subjected to UDL 20KN/m over entire span. If maximum allowable bending stress is taken as 50 N/mm^2 .determine dimensions of beam. Take $d=2b$ and span of beam =5m.	A	5	
	d) A beam carries a UDL 20KN/m over entire span of 6m. Beam has circular section of diameter 150mm. Determine maximum shear stress at a section 2m from the support.	A	5	
	e) A bar of 20mm in diameter and 1m length is subjected to a load of 1KN which is dropped from a height of 500mm on to the collar attached at other end of bar. Determine the instantaneous stress induced due to this impact load if $E=200 \times 10^3 \text{ MPa}$.	A	6	
	f) i) State relation between moment of inertia ,area and radius of gyration. State its SI unit. ii)Differential between gradually applied load and suddenly applied load [any two points]	U	4	6

Diagrams

For section II.

Q6 - a [Dia No: $\frac{1}{4}$].

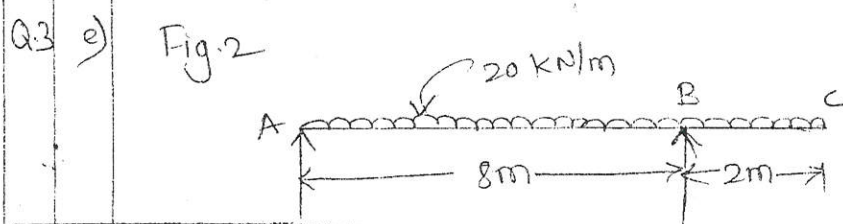
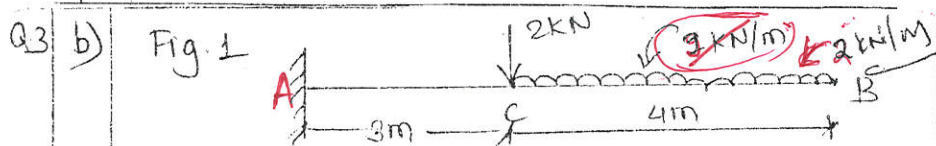
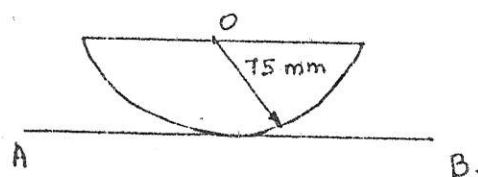

GOVERNMENT POLYTECHNIC, KOLHAPUR – 416004.

(An Autonomous Institute of Govt. Of Maharashtra)

WINTER/SUMMER- 2024

EXAM. SEAT NO.

LEVEL : - **FIFTH**

PROGRAM : **CIVIL ENGINEERING**

COURSE CODE :- **CEG506/CEF507**

COURSE NAME :- **IRRIGATION ENGINEERING**

MAX. MARKS : **80** TIME : **03 Hrs** DATE :- **03/5/2024**

Instruction :-

- 1) Answers of two sections must be written in separate section answer book provided.
- 2) Illustrate your answers with sketches wherever necessary.
- 3) Use of non-programmable pocket calculator is permissible.
- 4) Mathematical and other tables shall be made available on request.
- 5) Assume and mention suitable additional data if necessary.
- 6) Use of Mobile is strictly prohibited.
- 7) QN- Question No., SQN-Sub Question No. R- Remembering, U- Understanding, A- Application.

Q.N	S Q N	SECTION - I	R/ U/ A	CO	Ma rks														
Q.1		Attempt any FOUR :			08														
	a)	State the importance of irrigation.	U	1															
	b)	State the meaning of term- catchment area.	U	1															
	c)	Define the terms i) Gross command area (GCA) and ii) Culturable command area (CCA)	R	2															
	d)	What is mean by Percolation tank?	U	3															
	e)	What are the different types of Bandharas?	R	3															
	f)	What are the different types of Tube-wells?	R	3															
Q.2		Attempt any FOUR :			16														
	a)	Define the terms runoff. State the factors affecting runoff.	U	1															
	b)	Use of Thiessen Polygon method to Calculate the average rainfall from the following data:	A	1															
		<table border="1" style="margin-left: auto; margin-right: auto; border-collapse: collapse;"> <thead> <tr> <th style="padding: 5px;">Rain Gauge Strength</th> <th style="padding: 5px;">A</th> <th style="padding: 5px;">B</th> <th style="padding: 5px;">C</th> <th style="padding: 5px;">D</th> </tr> </thead> <tbody> <tr> <td style="padding: 5px;">Area of Thiessen Polygon (Sq. Km)</td> <td align="center" style="padding: 5px;">44</td> <td align="center" style="padding: 5px;">37</td> <td align="center" style="padding: 5px;">31.6</td> <td align="center" style="padding: 5px;">39</td> </tr> <tr> <td style="padding: 5px;">Precipitation (mm)</td> <td align="center" style="padding: 5px;">31.8</td> <td align="center" style="padding: 5px;">35.6</td> <td align="center" style="padding: 5px;">33.6</td> <td align="center" style="padding: 5px;">25.6</td> </tr> </tbody> </table>	Rain Gauge Strength	A	B	C	D	Area of Thiessen Polygon (Sq. Km)	44	37	31.6	39	Precipitation (mm)	31.8	35.6	33.6	25.6		
Rain Gauge Strength	A	B	C	D															
Area of Thiessen Polygon (Sq. Km)	44	37	31.6	39															
Precipitation (mm)	31.8	35.6	33.6	25.6															
	c)	State the considerations for the selection of the site for Percolation tank	A	3															
	d)	State any two advantages and disadvantages of Well irrigation.	R	3															
	e)	State the Advantages of Minor Irrigation schemes.	U	3															
	f)	Explain in brief drip irrigation method with a neat sketch.	A	2															
Q.3		Attempt any FOUR :			16														
	a)	What measures you will suggest to improve the duty ?	A	2															
	b)	Enlist any two rain gauge. Describe anyone with a neat sketch.	R	1															
	c)	Calculate the discharge required of the head of the distributory from the following culturable irrigation area = 78 % of gross area. Intensity of irrigation = 50 % for Rabi, Intensity of irrigation = 50 % for Kharif, Average duty of head of distributory = 220 Ha/ Cu. M for Rabi, Average duty of head of distributory = 880 Ha/ Cu. M for Kharif,	A	2															
	d)	State advantages and disadvantages of lift irrigation scheme.	U	3															
	e)	Describe with sketch the construction of K.T.Weir.	U	3															
	f)	State any four factors for site selection for Bandhara Irrigation.	U	3															

GOVERNMENT POLYTECHNIC, KOLHAPUR – 416004.

(An Autonomous Institute of Govt. Of Maharashtra)

SUMMER- 2024**EXAM. SEAT NO.**

--	--	--	--	--	--

LEVEL : - FIFTH

PROGRAM : CIVIL ENGINEERING

COURSE CODE :-CEG506/CEF507

COURSE NAME :- IRRIGATION ENGINEERING

MAX. MARKS : 80 TIME : 03 Hrs DATE :- 03/ 5/ 2024

QN	S Q N	SECTION -II	R/ U/ A	CO	Ma rks
Q.4		Attempt any FOUR :			08
	a)	What do you mean by Dead storage?	U	CEG506-4	
	b)	State the meaning of gravity dam.	U	CEG506-5	
	c)	State different types of earthen dams.	R	CEG506-5	
	d)	Name the different types of spillways.	R	CEG506-5	
	e)	State the function of- i) Aqueduct ii) Superpassage	R	CEG506-6	
	f)	What is meant by waterlogging ?	U	CEG506-6	
Q.5		Attempt any FOUR :			16
	a)	What important points should be considered while selecting the site for a storage reservoir?	A	CEG506-4	
	b)	State the main points to be considered while selecting a site for a gravity dam construction.	R	CEG506-5	
	c)	Distinguish between the elementary and practical profile of a solid gravity dam.	U	CEG506-5	
	d)	Draw a section of earth dam commonly adopted and also label the important components on it.	A	CEG506-5	
	e)	Give the meaning of – i)Capacity of canal ii) Design discharge iii) Rotation period iv) Time factor	R	CEG506-6	
	f)	Mention the advantages of lining of canal.	R	CEG506-6	
Q.6		Attempt any FOUR :			16
	a)	Define the Terms : (i) HFL (ii) FSL (iii) TBL (iv) LWL	R	CEG506-4	
	b)	State the purpose of spillway in a dam.	U	CEG506-5	
	c)	Name two automatic gates and describe anyone out of it.	R	CEG506-5	
	d)	What is the function of energy dissipater ? Where it is located? What happens if it is omitted?	U	CEG506-5	
	e)	What is the function of silt excluder and silt ejector?	R	CEG506-6	
	f)	State the effects of Salt Efflorescence.	U	CEG506-6	

GOVERNMENT POLYTECHNIC, KOLHAPUR – 416004.

(An Autonomous Institute of Govt. Of Maharashtra)

/SUMMER- 2024

EXAM SEAT NO.

--	--	--	--	--	--

LEVEL :- V

PROGRAM : CIVIL ENGINEERING

COURSE CODE :- CEG505 / CEF506

COURSE NAME :- ENVIRONMENTAL ENGINEERING

MAX. MARKS : 80 TIME : 03 Hrs DATE :- 2/5/24

Instruction :-

- 1) Answers of two sections must be written in separate section answer book provided.
- 2) Illustrate your answers with sketches wherever necessary.
- 3) Use of non-programmable pocket calculator is permissible.
- 4) Mathematical and other tables shall be made available on request.
- 5) Assume and mention suitable additional data if necessary.
- 6) Use of Mobile is strictly prohibited.
- 7) QN- Question No., SQN-Sub Question No. R- Remembering, U- Understanding, A- Application.

QN	S Q N	SECTION - I	R/ U/ A	Co	Ma rks
Q.1		Attempt any FOUR :			08
	a)	Define wholesome water.	R	1	
	b)	Enlist the methods used for measurement of turbidity.	R	1	
	c)	Enlist the objects/aims of aeration	R	2	
	d)	State the advantages of chlorination	R	2	
	e)	State the purpose of service Reservoirs.	R	3	
	f)	Enlist different types of pipes used for conveyance of water	R	3	
Q.2		Attempt any FOUR :			16
	a)	State the significance of 'pH' value in water treatment. Also give value of pH suitable for drinking water	A	1	
	b)	Explain water sample collection procedure for various test and from different sources	U	1	
	c)	Enlist the methods of population forecasting and explain any one of with suitable example assuming suitable data	U	1	
	d)	Draw the labeled sketch of 'Flash Mixer' and explain its working.	U	2	
	e)	Explain theory of filtration	U	2	
	f)	Enlist methods of distribution system and explain any one with neat sketch	U	3	
Q.3		Attempt any FOUR :			16
	a)	Define intake and enlist factors governing location of intake	U	1	
	b)	Explain Domestic water demand and Losses and Waste demand For Indian city	A	1	
	c)	Explain 'Break point chlorination' with neat sketch.	A	2	
	d)	Explain the back washing process of rapid sand filter with sketch.	A	2	
	e)	Enlist and explain the different forms of chlorination.	U	2	
	f)	Enlist any four types of valves provided on water pipe line, also State the Location and Function of each.	A	3	

P.T.O.

GOVERNMENT POLYTECHNIC, KOLHAPUR – 416004.

(An Autonomous Institute of Govt. Of Maharashtra)

SUMMER- 2024

EXAM. SEAT NO.

--	--	--	--	--	--

LEVEL :- FIFTH

PROGRAM : DIPLOMA IN CIVIL ENGINEERING

COURSE CODE :- CEG505 / CEF 506

COURSE NAME :- ENVIRONMENTAL ENGINEERING

MAX. MARKS : 80 TIME : 03 Hrs DATE :- 2/5/2024

Instruction :-

- 1) Answers of two sections must be written in separate section answer book provided.
- 2) Illustrate your answers with sketches wherever necessary.
- 3) Use of non-programmable pocket calculator is permissible.
- 4) Mathematical and other tables shall be made available on request.
- 5) Assume and mention suitable additional data if necessary.
- 6) Use of Mobile is strictly prohibited.
- 7) QN- Question No., SQN-Sub Question No. R- Remembering, U- Understanding, A- Application

Q.N	S Q N	SECTION –II	R/ U/ A	CO	Ma rks
Q.4		Attempt any FOUR :			08
	a)	State meaning of term 'House Drainage'.	U	CEG505-4	
	b)	Define 'Trap'. What is the function of Trap?	R	CEG505-4	
	c)	Define the following terms –i) Vent pipe ii) Soil pipe	R	CEG505-4	
	d)	What are 'Manholes'? How they are classified?	U	CEG505-5	
	e)	What do you mean by 'Self cleansing velocity'?	U	CEG505-5	
	f)	Define 'Chemical Oxygen demand' (C.O.D.)	R	CEG505-6	
Q.5		Attempt any FOUR :			16
	a)	What are the fundamental principles of sanitation?	U	CEG505-4	
	b)	Draw the lay-out plan 'showing house drainage system'.	A	CEG505-4	
	c)	Draw the labeled sketch of following and explain in brief. i) Intercepting trap ii) Gully trap	U	CEG505-4	
	d)	Draw the labeled sketch of septic tank and explain its working.	U	CEG505-5	
	e)	Describe the procedure of laying and testing of sewers in brief.	A	CEG505-5	
	f)	What is 'Drop manhole'? What are its objects?	U	CEG505-5	
Q.6		Attempt any FOUR :			16
	a)	Draw the sketch showing 'Two Pipe System' of sanitation and write advantages and disadvantages of it.	A	CEG505-4	
	b)	Enlist the methods of disposal of Dry Refuse and explain any one method in brief.	U	CEG505-4	
	c)	Describe briefly 'Anaerobic decomposition processes'.	U	CEG505-6	
	d)	Draw the flow diagram showing 'Activated sludge processes' and explain its working	U	CEG505-6	
	e)	What is skimming tank? State its purpose and location.	U	CEG505-6	
	f)	What is oxidation pond? State its principle of working.	U	CEG505-6	

GOVERNMENT POLYTECHNIC, KOLHAPUR – 416004

(An Autonomous Institute of Govt. Of Maharashtra)

SUMMER 2024

EXAM SEAT NO.

--	--	--	--	--	--

LEVEL :- **Third**

PROGRAM : **Civil Engineering**

COURSE CODE : **CEG306/CEF306**

COURSE NAME : **HYDRAULICS**

MAX. MARKS : **80** TIME : **3 HRS.** DATE :- **02 May 2024**

Instruction :-

- 1) Answers must be written in the main answer book provided (and supplements if required).
- 2) Illustrate your answers with sketches wherever necessary.
- 3) Use of non-programmable pocket calculator is permissible.
- 4) Mathematical and other tables shall be made available on request.
- 5) Assume and mention suitable additional data if necessary.
- 6) Use of Mobile is strictly prohibited.
- 7) QN- Question No., SQN-Sub Question No. R- Remembering, U- Understanding, A- Application.

QN	S Q N	Question Text	R/ U/ A	CO	Mar ks
Q.1		Attempt any FOUR :			08
	a)	Find the surface tension in soap bubble of 40 mm diameter when the inside pressure is 2.5N/m^2 above atmospheric pressure.	A	1	
	b)	State Pascal's law of fluid pressure.	R	2	
	c)	Differentiate between steady and unsteady flow.	A	3	
	d)	Define specific weight of fluid.	R	1	
	e)	Express 10m of oil specific gravity 0.85 into pressure head of liquid having specific gravity 1.50.	A	2	
	f)	Define Reynolds number.	R	3	
Q.2		Attempt any FOUR :			16
	a)	Explain with neat sketch the working of Bourdon's pressure gauge.	U	1	
	b)	A concrete dam of rectangular section 15m deep and 8m wide containing water upto 13m. Find i) Total pressure of water on 1m length. ii) Depth of center of pressure above base iii) The point at which resultant cuts the base.	A	2	
	c)	A horizontal pipe carrying water tapers from 20cm diameter at A to 10cm diameter at B in a length of 2m. The pressure at A is 100N/cm^2 . If discharge is 600lit/min. Calculate pressure at B in N/cm^2 . If loss of head from A to B is 10cm.	A	3	
	d)	A liquid weight 25KN and occupies 3.75m^3 . Find its specific weight, mass density specific gravity and specific volume.	A	1	
	e)	Explain the concept and use of pressure diagram with neat sketches.	U	2	
	f)	Explain flow net and state its uses .	U	3	

Q.3	Attempt any FOUR :			16
	a) A simple manometer (U tube) containing mercury is connected to a pipe in which an oil of specific gravity 0.8 is flowing. The pressure in the pipe is vacuum. The other end of the manometer is open to the atmosphere. Find vacuum pressure in pipe, if the difference of mercury level in the two limbs is 20cm and height of oil in the left limb from center of pipe is 15cm below.	A	1	
	b) Explain i) Atmospheric pressure ii) absolute pressure iii) Gauge pressure iv) Vacuum pressure	U	2	
	c) A circular plate of 4 m diameter is immersed vertically in water so that its upper edge is 1m below the water. The plate is having a triangular hole which has a base of 80 cm and height 60cm in such position that its vertex coincides with the center of plate as shown in Fig. Find total pressure acting on the plate and its center of pressure. Refer fig No. 1	A	2	
	d) Explain datum head, pressure head, velocity head and total head and give expression for each.	U	3	
	e) Find the intensity of pressure in N/m^3 on the base of container when i) when water stands at a height of 1.25m in it. ii) When oil for 0.625 m height stands on water of 1m height. Draw pressure diagram to all cases.	A	2	
	f) An oil of specific gravity 0.95 is flowing through a pipeline of 200mm diameter at the rate of 50lit/sec. Find the Reynolds number and comment on it. Take viscosity for the oil as $0.10 N.S/m^2$.	A		
Q.4	Attempt any FOUR :			08
	a) Find head loss due to friction from following data $d= 100cm$ length of pipe $=1500m$ $V = 1m/sec$ $f= 0.020$	A	4	
	b) Define Weir.	R	5	
	c) What is hydraulic gradient line.	R	4	
	d) Determine the discharge through 60° triangular notch in lit/sec when the head is 0.20m. Take $C_d=0.6$	A	4	
	e) What is most economical section.	R	5	
	f) Define Priming.	R	6	
Q.5	Attempt any FOUR :			16
	a) What is water hammer? State its remedial measures.	U	4	
	b) Two reservoirs connected by three pipes in parallel. Their diameters are $d, 2d$ and $3d$ having same length and same frictional factor of pipes Determine the discharge through large pipe if discharge through smaller pipe is $2m^3/sec$.	A	4	
	c) The head of water over an orifice of diameter 4cm is 10m. If $C_d = 0.6$ and $C_v = 0.98$. Find the actual discharge and actual velocity of the jet at vena contract.	A	4	
	d) A trapezoidal channel has side slope 1.5 H to 1V and bed slope 1 in 4000. Find the dimension of the most economical section of the channel if it has to pass a discharge of $10m^3/sec$. assume N in Manning's formula as 0.012	A	5	

	e)	A rectangular channel is 1.5 m deep & 6m wide. Find the discharge through channel when it runs full. Take slope of the bed as 1 in 900 & Chezy's constant as 50.	A	5	
	f)	State expression for discharge for triangular notch.	A	5	
Q.6		Attempt any FOUR :			16
	a)	Calculate the loss of head per kilometer length of a new cast iron pipe having 40cm diameter friction factor $f=0.04$, discharge of water 10lit/sec.	A	5	
	b)	State the expression for minor losses for following i) at entrance ii) sudden enlargement iii) sudden contraction iv) Exit	U	4	
	c)	A centrifugal pump is required to lift water against a total head of 30m at rate of 60 lit/sec. Find the horse power required of the pump if efficiency is 80%.	A	6	
	d)	Water at a rate of $0.1\text{m}^3/\text{s}$ through 2m diameter vertical sewer pipe is fully flowing. Find the slope of pipe if Manning's N is 0.013	A	5	
	e)	State and explain hydraulic Jump and write its uses. Where it occurs?	U	5	
	f)	The diameter of horizontal pipe suddenly changes from 20cm to 25cm. The discharge from pipe is 350liters per sec. Calculate loss of head when i) water flows from smaller diameter pipe to larger diameter pipe & ii) water flows is reversed with same discharge.	A	4	

3 C

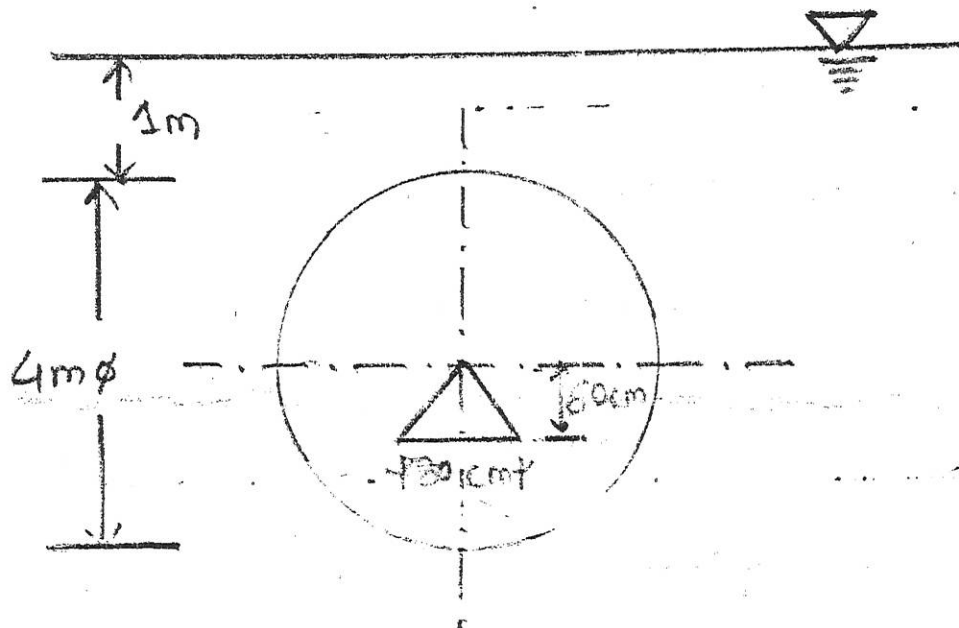

FIG NO 1 . Q3.C

