

GOVERNMENT POLYTECHNIC, KOLHAPUR – 416004.

(An Autonomous Institute of Govt. Of Maharashtra)

EVEN TERM END EXAM SUMMER -2024**EXAM SEAT NO.**

--	--	--	--	--	--

LEVEL :- **FIRST**PROGRAM : **COMMON**COURSE CODE :- **CCG203**COURSE NAME **Communication skill in English**MAX. MARKS : **40** TIME : **02Hrs.**DATE :- **24/05/2024**

Instruction :-

- 1) Answers must be written in the main answer book provided.(and supplements if required)
- 2) Illustrate your answers with sketches wherever necessary.
- 3) Use of non-programmable pocket calculator is permissible.
- 4) Mathematical and other tables shall be made available on request.
- 5) Assume and mention suitable additional data if necessary.
- 6) Use of Mobile is strictly prohibited.
- 7) QN- Question No., SQN-Sub Question No. R- Remembering, U- Understanding, A- Application.

QN	S Q N	Question Text	R/ U/ A	Co CCG 203	Mar ks
Q.1		Attempt any FOUR :(Answer the following questions in 3-5 sentences)			08
	a)	Explain in brief 'positive feedback' in your own words.	U	1	
	b)	Describe any two disadvantages of Oral communication.	R	2	
	c)	Enlist four examples in which Written communication is used.	U	3	
	d)	Write at least one strength and one precaution of Media-Aided presentation.	R	5	
	e)	Describe 'Mock Interview' in short.	U	6	
	f)	Write at least two expected questions which can be asked in a job interviews.	U	6	
Q.2		Attempt any FOUR (answer the following questions in 12-14 sentences)			16
	a)	Explain with suitable example with neat labelled diagram:- i) Horizontal communication ii) Diagonal communication	U	1	
	b)	Give a situation of your own where the communication cycle is complete. Identify the elements of communication in the situation.	A	1	
	c)	Describe in detail at least four characteristics of Oral communication in your own words.	R	2	
	d)	Explain merits and demerits of Written communication.	U	3	
	e)	State any four precautions that one should take while making a presentation.	R	5	
	f)	Explain the importance of dress and appearance, soft make-up, descent jewellery of a candidate who is going to face an interview for a job.	A	6	
Q.3		Attempt any TWO (Do as directed in the question)			16
	a)	Draw a neat labelled diagram of communication cycle with its elements. Explain in detail with suitable example each element involved in the communication process.	U	1	
	b)	Write an application with your resume to the Managing Director, Swan Industries, Mumbai for the post of an Executive Engineer.	A	3	

P.T.O.

c) Draw a bar graph with the help of following data. Indicate the components, figures and the period of time in the graph. Use pencil shading, formal color scheme, design etc. to make the graph attractive -----

Incidents of Railway Accidents in India

Year →	2020	2021	2022
Causes ↓			
Failure of Signal	20	15	10
Administration Lapse	15	20	10
Negligence	30	20	30
Unknown	10	10	40
Total	75	65	90

A

4

GOVERNMENT POLYTECHNIC, KOLHAPUR – 416004.

(An Autonomous Institute of Govt. Of Maharashtra)

SUMMER-2024

EXAM SEAT NO.

--	--	--	--	--	--

LEVEL : First

PROGRAM : COMMON

COURSE CODE :- CCH105

COURSE NAME: BASIC MATHEMATICS

MAX. MARKS : 70

TIME : 03 Hrs

DATE :- 25/5/2024

QN	S Q N	Question Text	R/ U/ A	Co	Ma rks
Q.4		Attempt any FOUR: (2 X 4)			08
	a)	$2\cos 60^\circ \cdot \cos 10^\circ = \cos A + \cos B$. Find A & B.	R	4	
	b)	If $f(x) = x^3 + x^2 - 2$, find $f(1) + f(2)$	R	5	
	c)	State whether the function $f(x) = \frac{e^x + e^{-x}}{2}$ is even or odd	R	5	
	d)	Find $\frac{dy}{dx}$ if $y = x^e + e^x + e^e + a^x$	U	5	
	e)	Find $\frac{dy}{dx}$ if $y = e^{2x} \cdot (x^3 + 4)$	U	5	
	f)	Find the slope of the tangent to the curve $xy = 6$ at (1,6)	A	5	
Q.5		Attempt any FOUR: (4 X 4)			16
	a)	Without using calculator find the value of $\sin 150^\circ + \cos 300^\circ - \tan 315^\circ + \sec^2 366^\circ$	U	4	
	b)	Prove that, $\frac{\sin 8x - \sin 5x}{\cos 7x + \cos 6x} = \sin x + \cos x \cdot \tan \frac{x}{2}$	U	4	
	c)	Show that $\tan^{-1}\left(\frac{1}{2}\right) + \tan^{-1}\left(\frac{1}{3}\right) = \frac{\pi}{4}$	U	4	
	d)	Find $\frac{dy}{dx}$ if $x^3 + y^3 = 3axy$	U	5	
	e)	If $x = a(\cos t + t \sin t)$ and $y = a(\sin t - t \cos t)$ find $\frac{dy}{dx}$ at $t = \frac{\pi}{4}$	A	5	
	f)	Find the radius of curvature at (3,-4) to the curve $x^2 + y^2 = 25$.	U	5	
Q.6		Attempt any TWO: (6 X 2)			12
	a)	i) If $\tan A = \frac{1}{2}, \tan B = \frac{1}{3}$ find $\tan(A + B)$ ii) If $\sin A = 0.4$ find $\cos 2A$ using multiple angle formula	R	4	
	b)	Find $\frac{dy}{dx}$ if $y = x^{\sin x} + \tan x^x$	U	5	
	c)	i) Find $\frac{dy}{dx}$ if $y = \frac{1+\sqrt{x}}{1-\sqrt{x}}$ ii) Find equation of tangent to the curve $y = x(2 - x)$ at the point (2,0)	A	5	

GOVERNMENT POLYTECHNIC, KOLHAPUR – 416004.

(An Autonomous Institute of Govt. Of Maharashtra)

SUMMER-2024

EXAM SEAT NO.

--	--	--	--	--	--

LEVEL :- First

PROGRAM : COMMON

COURSE CODE :- CCH105

COURSE NAME :- Basic Mathematics

MAX. MARKS : 70

TIME : 03 Hrs

DATE :- 25/5/2024

Instruction :-

- 1) Answers of two sections must be written in separate section answer book provided.
- 2) Illustrate your answers with sketches wherever necessary.
- 3) Use of non-programmable pocket calculator is permissible.
- 4) Mathematical and other tables shall be made available on request.
- 5) Assume and mention suitable additional data if necessary.
- 6) Use of Mobile is strictly prohibited.
- 7) QN- Question No., SQN-Sub Question No. R- Remembering, U- Understanding, A- Application.

QN	S QN	Question Text	R/ U/ A	Co	Mar ks												
Q.1		Attempt any THREE: (2 X 3)			06												
	a)	Find the value of x, if $\log_3(x + 6) = 2$	R	1													
	b)	If $A = \begin{bmatrix} 2 & 3 \\ 4 & 7 \end{bmatrix}$ $B = \begin{bmatrix} 1 & 3 \\ 4 & 6 \end{bmatrix}$ Find $3A-2B$	U	1													
	c)	Resolve into partial fraction $\frac{1}{x^2+3x+2}$	U	1													
	d)	Find equation of line passing through the points (-4,6) and (8,-3)	U	3													
	e)	Calculate range of the following data <table border="1" style="margin: 5px auto; border-collapse: collapse;"> <tr> <td>X_i</td> <td>10</td> <td>20</td> <td>30</td> <td>40</td> <td>50</td> </tr> <tr> <td>f_i</td> <td>7</td> <td>5</td> <td>3</td> <td>2</td> <td>1</td> </tr> </table>	X_i	10	20	30	40	50	f_i	7	5	3	2	1	R	2	
X_i	10	20	30	40	50												
f_i	7	5	3	2	1												
Q.2		Attempt any FOUR: (4 X 4)			16												
	a)	Find x, y and z if $\left\{ \begin{bmatrix} 1 & 3 & 2 \\ 2 & 0 & 1 \\ 3 & 1 & 2 \end{bmatrix} + 2 \begin{bmatrix} 3 & 0 & 2 \\ 1 & 4 & 5 \\ 2 & 1 & 0 \end{bmatrix} \right\} \begin{bmatrix} 1 \\ 2 \\ 3 \end{bmatrix} = \begin{bmatrix} x \\ y \\ z \end{bmatrix}$	U	1													
	b)	Resolve into partial fraction $\frac{9}{(x-1)(x+2)^2}$	A	1													
	c)	Resolve into partial fraction $\frac{3x+2}{(x^2+1)(x+1)}$	U	1													
	d)	The two sets of observations are given below. <table border="1" style="margin: 5px auto; border-collapse: collapse;"> <tr> <td style="width: 50%; text-align: center;">Set I</td> <td style="width: 50%; text-align: center;">Set II</td> </tr> <tr> <td style="text-align: center;">Mean = 82.5</td> <td style="text-align: center;">Mean = 48.75</td> </tr> <tr> <td style="text-align: center;">S.D = 7.3</td> <td style="text-align: center;">S.D = 8.35</td> </tr> </table> Which of two sets is more consistent?	Set I	Set II	Mean = 82.5	Mean = 48.75	S.D = 7.3	S.D = 8.35	A	2							
Set I	Set II																
Mean = 82.5	Mean = 48.75																
S.D = 7.3	S.D = 8.35																
	e)	Find equation of line parallel to $3x-2y+5 = 0$ and passing through the point(5,-6)	A	3													
	f)	find the mean deviation from mean of the following data <table border="1" style="margin: 5px auto; border-collapse: collapse;"> <tr> <td style="width: 15%;">Marks</td> <td style="width: 15%;">0-10</td> <td style="width: 15%;">10-20</td> <td style="width: 15%;">20-30</td> <td style="width: 15%;">30-40</td> <td style="width: 15%;">40-50</td> </tr> <tr> <td>No.of students</td> <td>05</td> <td>08</td> <td>15</td> <td>16</td> <td>6</td> </tr> </table>	Marks	0-10	10-20	20-30	30-40	40-50	No.of students	05	08	15	16	6	A	2	
Marks	0-10	10-20	20-30	30-40	40-50												
No.of students	05	08	15	16	6												
Q3		Attempt any TWO: (6 X 2)			12												
	a)	Calculate standard deviation and coefficient of variance of the following distribution <table border="1" style="margin: 5px auto; border-collapse: collapse;"> <tr> <td style="width: 15%;">Marks</td> <td style="width: 15%;">5</td> <td style="width: 15%;">10</td> <td style="width: 15%;">15</td> <td style="width: 15%;">20</td> <td style="width: 15%;">25</td> </tr> <tr> <td>No.of students</td> <td>6</td> <td>16</td> <td>28</td> <td>38</td> <td>46</td> </tr> </table>	Marks	5	10	15	20	25	No.of students	6	16	28	38	46	A	2	
Marks	5	10	15	20	25												
No.of students	6	16	28	38	46												
	b)	i) Find the length of perpendicular from the point (5,6) on the line $2x+y+6 = 0$ ii) Find the acute angle between the lines $3x-y=4$, $2x+y=3$	A U	3 3													
	c)	Solve the equation using matrix inversion method , $X+3y+2z = 6$, $3x-2y+5z= 5$, $2x-3y+6z = 7$	A	1													

GOVERNMENT POLYTECHNIC, KOLHAPUR – 416004.

(An Autonomous Institute of Govt. Of Maharashtra)

EVEN TERM END EXAM SUMMER -2024**EXAM SEAT NO.**

--	--	--	--	--	--

LEVEL :- **FIRST** PROGRAM : **CE/ME/MT**COURSE CODE :- **CCG103/CCF103**COURSE NAME **ENGINEERING CHEMISTRY**MAX. MARKS : **80** TIME : **03Hrs.** DATE :- **04/05/2024**

Instruction :-

- 1) Answers must be written in the main answer book provided.(and supplements if required)
- 2) Illustrate your answers with sketches wherever necessary.
- 3) Use of non-programmable pocket calculator is permissible.
- 4) Mathematical and other tables shall be made available on request.
- 5) Assume and mention suitable additional data if necessary.
- 6) Use of Mobile is strictly prohibited.
- 7) QN- Question No., SQN-Sub Question No. R- Remembering, U- Understanding, A- Application.

QN	S Q N	Question Text	R/ U/ A	Co CCG 103	Mar ks
Q.1		Attempt any FOUR :			08
	a)	Define atom.	R	1	
	b)	Distinguish between atomic number and atomic mass number.	U	1	
	c)	Define electrolysis	R	2	
	d)	What is degree of ionisation?	U	2	
	e)	Define catalyst.	R	3	
	f)	State different types of catalyst.	R	3	
Q.2		Attempt any FOUR :			16
	a)	Explain Bohr's theory of atom.	U	1	
	b)	State the applications of electrolysis and explain any one of them.	U	2	
	c)	Explain the formation of CaCl ₂ molecule on the basis of electrovalency .	U	1	
	d)	With neat labelled diagram explain the electrolysis of molten NaCl.	U	1	
	e)	Define corrosion. Explain atmospheric corrosion.	U	2	
	f)	Explain the process used for protection of large and irregular shaped articles from corrosion.	A	2	
Q.3		Attempt any FOUR :			16
	a)	Write the characteristics of good insulator.	U	3	
	b)	State the properties and uses of Glass wool.	U	3	
	c)	What are composite materials? Write their properties and uses.	U	3	
	d)	Distinguish between polymerisation by addition and polymerization by condensation.	U	3	
	e)	Explain vulcanization of rubber.	U	3	
	f)	Write the properties and uses of adhesives.	U	3	

QN	S Q N	Question Text	R/ U/ A	Co CCG 103	M ar ks
Q.4		Attempt any FOUR :			08
	a)	Name the chemicals used for regeneration of cation exchange resin and anion exchange resin.	R	4	
	b)	Define Lubricant and Lubrication.	R	6	
	c)	Give composition of woods metal.	U	3	
	d)	List out any two ores of iron with their chemical formulae.	R	5	
	e)	What is temporary and permanent hardness of water?	U	4	
	f)	List out the various constituents of Paints.	R	2	
Q.5		Attempt any FOUR :			16
	a)	How the terms flux and gangue are complementary to each other? Explain with chemical equations.	A	4	
	b)	Write characteristics of good lubricant.	U	6	
	c)	What is Soap? Explain reaction of hard water with soap.	U	4	
	d)	Distinguish between paints and varnishes.	U	6	
	e)	Describe disadvantages of hard water in sugar industry and paper industry.	A	4	
	f)	Explain purposes of making alloys.	U	2	
Q.6		Attempt any FOUR :			16
	a)	Define roasting of ore. Write purposes of roasting.	U	5	
	b)	Write any four functions of a lubricant.	U	6	
	c)	Define Flash Point, fire point, Acid value and oiliness.	R	6	
	d)	What is sterilization? Explain chlorination process by using chlorine gas and chloramine with chemical reactions.	U	4	
	e)	Give composition, properties and applications of duralumin alloys.	A	2	
	f)	What is varnish? How is it classified? List constituents of varnish.	R	2	

GOVERNMENT POLYTECHNIC, KOLHAPUR – 416004

(An Autonomous Institute of Govt. Of Maharashtra)

SUMMER 2024

EXAM SEAT NO.

--	--	--	--	--	--

LEVEL :- **First**

PROGRAM : **EE/IT/E&TC/IE**

COURSE CODE : **CCG104/CCF103**

COURSE NAME : **Engineering Chemistry-**

MAX. MARKS : **80** TIME : **3 HRS.** DATE :- **04 May 2024**

Instruction :-

- 1) Answers must be written in the main answer book provided (and supplements if required).
- 2) Illustrate your answers with sketches wherever necessary.
- 3) Use of non-programmable pocket calculator is permissible.
- 4) Mathematical and other tables shall be made available on request.
- 5) Assume and mention suitable additional data if necessary.
- 6) Use of Mobile is strictly prohibited.
- 7) QN- Question No., SQN-Sub Question No. R- Remembering, U- Understanding, A- Application.

QN	S Q N	Question Text	R/ U/ A	CO	Mar ks
Q.1		Attempt any FOUR :			08
	a)	State Aufbau's principle.	R	1	
	b)	Define 1)Isotopes 2) Isobars	R	1	
	c)	Define 1)conductors 2)Electrolyte	R	1	
	d)	Define promotors with examples .	R	3	
	e)	Explain types of corrosion.	U	2	
	f)	Enlist types of Polymerization with definitions.	R	3	
Q.2		Attempt any FOUR :			16
	a)	Explain formation of H ₂ O molecules .	U	1	
	b)	Explain with labelled diagram electrolysis of CuSO ₄ solution using Cu electrode.	U	1	
	c)	Distinguish between galvanizing and tinning.	U	2	
	d)	Explain factors affecting atmospheric corrosion.	U	2	
	e)	Distinguish between homogenous and heterogenous catalystr.	U	3	
	f)	Explain preparation ,properties and uses of glass wool.	U	3	
Q.3		Attempt any FOUR :			16
	a)	Explain Bohr's theory of atom with diagram.	U	1	
	b)	State two properties and engineering applications of rubber.	U/A	3	
	c)	Define adhesive and explain characteristics of good adhesive.	U/A	3	
	d)	Explain with classification ,properties and uses of composite material.	U	3	
	e)	Explain engineering properties and applications of plastic.	U	3	
	f)	Explain Arrhenius theory of ionization.	U	1	

QN	S Q N	Question Text	R/ U/ A	Co MEF 503	Mar ks
Q.4		Attempt any FOUR :			08
	a)	Define sterilization. Enlist different types of chlorination.	U	4	
	b)	Explain two advantages of H ₂ - O ₂ fuel cell.	A	1	
	c)	Define primary & secondary battery.	U	1	
	d)	Explain occurrence of metals.	R	5	
	e)	Define Gangue & Flux.	R	5	
	f)	Memorize composition of soft solder.	U	6	
Q.5		Attempt any FOUR :			16
	a)	Distinguish between temporary and permanent hardness.(Any four points.)	U	4	
	b)	Explain disadvantages of Hard water in Paper Industry & Textile Industry.	A	4	
	c)	Explain construction & working of Dry Cell.	A	1	
	d)	Distinguish between calcination & Roasting. (4 points)	A	5	
	e)	Explain with diagram Gravity separation method.	U	5	
	f)	Enlist composition & two properties of brazing alloy & Plumber's solder.	R	6	
Q.6		Attempt any FOUR :			16
	a)	Explain Ion exchange method to remove total hardness of water.	A	4	
	b)	Distinguish between hard water & soft water. .(Any four points.)	U	4	
	c)	Define -Discharge ,Internal resistance ,Closed Circuit Voltage & E. M. F.	R	1	
	d)	Explain construction & working of Lead acid storage battery while charging.	U	1	
	e)	Explain smelting process of extraction of copper from copper pyrites.	U	5	
	f)	Enlist four properties & four uses of copper.	R	5	

GOVERNMENT POLYTECHNIC, KOLHAPUR – 416004.

(An Autonomous Institute of Govt. of Maharashtra)

WINTER / SUMMER-2024

EXAM SEAT NO.

--	--	--	--	--	--	--

LEVEL: - First

PROGRAM: ME/MT

COURSE CODE: - CCH110

COURSE NAME: - Engineering Drawing

MAX. MARKS: 70

TIME: 04Hrs

DATE: -04/05/2024

Instruction :-

- 1) Answers of two sections must be written in separate section answer book provided.
- 2) Illustrate your answers with sketches wherever necessary.
- 3) Use of non-programmable pocket calculator is permissible.
- 4) Mathematical and other tables shall be made available on request.
- 5) Assume and mention suitable additional data if necessary.
- 6) Use of Mobile is strictly prohibited.
- 7) QN- Question No., SQN-Sub Question No. R- Remembering, U- Understanding, A- Application.

QN	S Q N	SECTION -I	R/ U/ A	CO	Marks
Q.1		Attempt any TWO: (2 X 8M)			16
	a)	A pentagonal prism base side 25mm and axis length 60mm is standing on a corner of the base on H.P with its axis inclined at 45° to H.P. and parallel to V.P. Draw its projections.	U & A	CCH110 -01	
	b)	A cone base diameter 40mm and axis length 60mm is lying on one of its generators on V.P. with its axis parallel to H.P. Draw its projections.	U & A	CCH110 -01	
	c)	A tetrahedron of 60mm long edges has one edge in H.P. with that edge perpendicular to V.P. and the triangular face containing that edge is vertical (90°). Draw its three views.	U & A	CCH110 -01	
Q.2		Attempt any TWO: (2 X 9M)			18
	a)	Figure No. 1 Shows FV and TV of an object. Draw its isometric View. Consider 'O' as origine.	U & A	CCH110 -02	
	b)	Figure No.2 Shows FV and LHSV of an object. Draw its isometric projection. Draw Isometric scale. Consider 'O' as origine.	U & A	CCH110 -02	
	c)	Figure No. 3 Shows FV and TV of an object. Draw its isometric projection. Draw Isometric scale. Consider 'O' as origine.	U & A	CCH110 -02	

Y4

PTO -

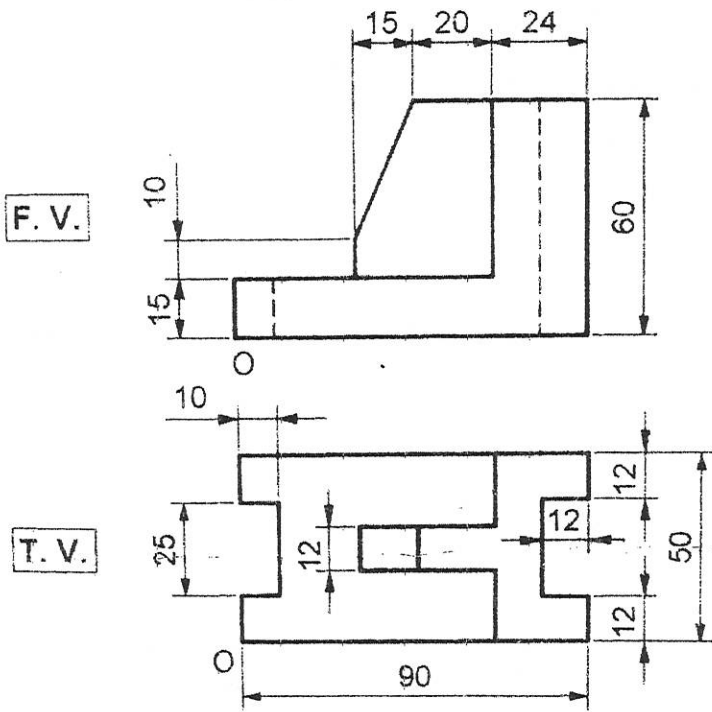

Figure No. 1

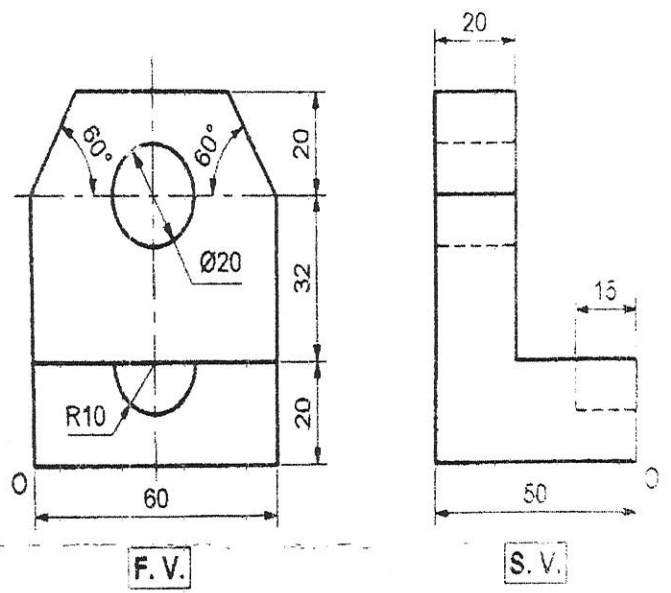

Figure No. 2

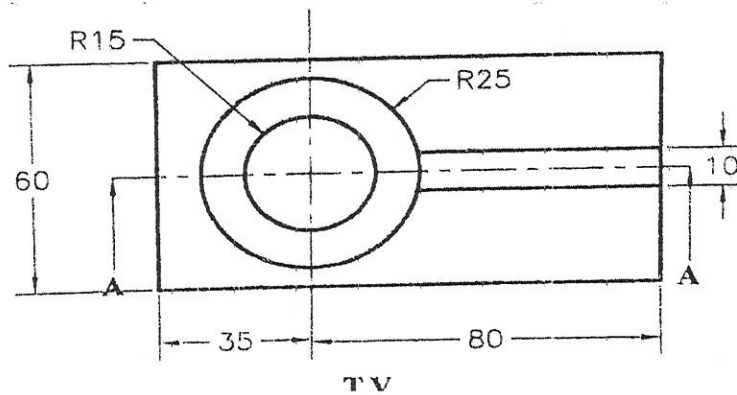
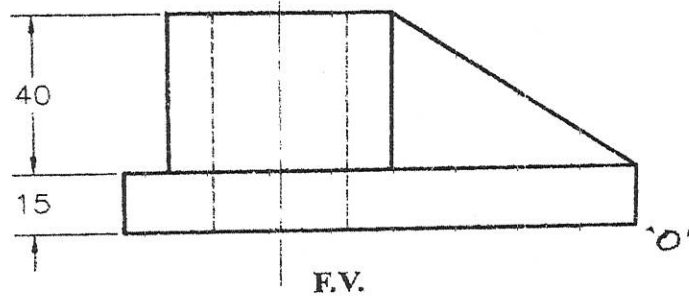

Figure No. 3

214

P.T.O.

GOVERNMENT POLYTECHNIC, KOLHAPUR – 416004.

(An Autonomous Institute of Govt. Of Maharashtra)

SUMMER- 2024

EXAM SEAT NO.

LEVEL: - **First**

PROGRAM: **ME/MT**

COURSE CODE: - **CCH110**

COURSE NAME: - **ENGINEERING DRAWING**

MAX. MARKS: **70**

TIME: **4 Hrs**

DATE: **-04/05/2024.**

QN	S Q N	Question Text	R/ U/ A	Co	Ma rks
Q.3		Attempt any TWO: (7 X 2)			14
	a)	<p>Figure No. 4 shows Front and Top view of an object. Draw the following views using first angle method: (i) Front View (ii) Top view (iii) Left hand side view.</p> <div style="text-align: center;"> </div> <p align="center">Figure No. 4</p>	U	3	7
	b)	<p>Draw the following views of an object shown in Figure No. 5, use first angle method: (i) Sectional Front View (ii) Top view (iii) Left hand side view.</p> <div style="text-align: center;"> </div> <p align="center">Figure No. 5</p>	U	3	7

c) Figure No.6 shows front view and top view of the object. Draw the following views of the object. (Use first angle method): (i) Front view (ii) Top view (iii) LHSV.

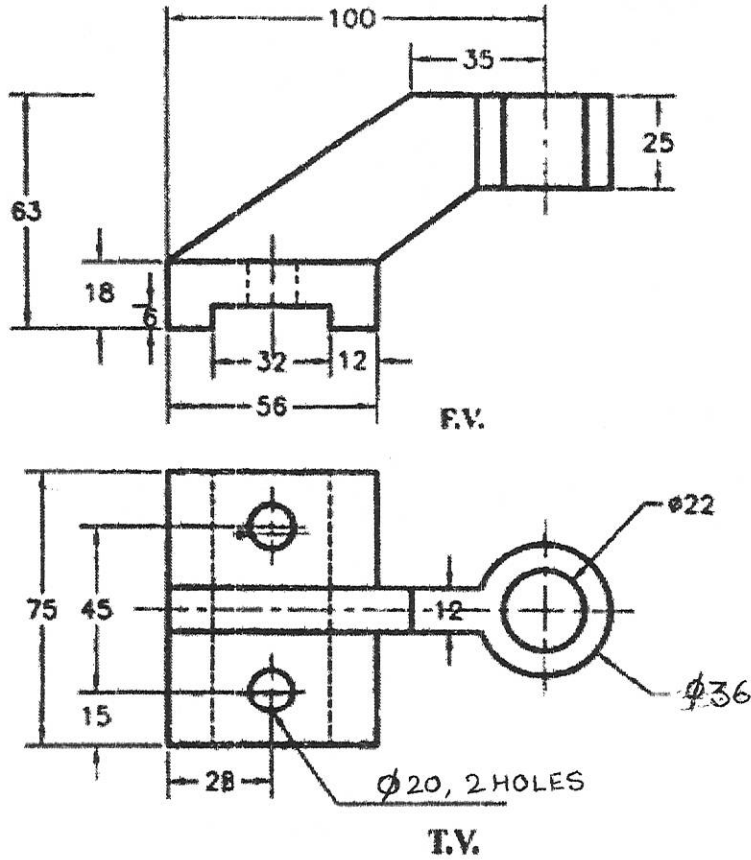

Figure No. 6

Q.4 Attempt any TWO: (6 X 2)

a) Draw development of surface of a cylinder having base diameter 50 mm and axis height 80 mm kept of HP. It is cut by a cutting plane which is inclined at 45° with HP and bisecting axis of cylinder.

b) A square prism of base side 40 mm and axis height 90 mm is rest on HP such that its side of base equally inclined with VP. A circular hole of diameter ~~55~~ 45 mm is drilled through prism such that axis of hole is perpendicular to VP and parallel to HP and bisect axis of square prism. Draw development of surface of prism.

c) Figure No. 7 shows FV of a square pyramid. Draw the development of lateral surfaces of a pyramid.

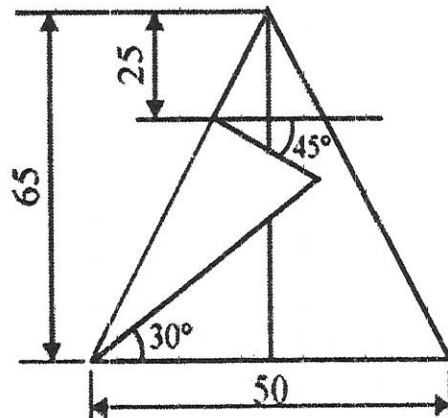

Fig No. 7

Q.5 Attempt any FIVE: (2 X 5)

- a) Draw neat and proportionate freehand sketch of Rag foundation bolt.
- b) Draw conventional representation of Withworth thread.
- c) Draw neat and proportionate freehand sketch of Hexagonal nut.
- d) Draw neat and proportionate freehand sketch of Eye bolt.
- e) Draw the conventional representation Double rivetted lap joint.
- f) Draw neat and proportionate freehand sketch of Lock nut.
- g) Draw neat and proportionate freehand sketch of Plain washer.

GOVERNMENT POLYTECHNIC, KOLHAPUR – 416004

(An Autonomous Institute of Govt. Of Maharashtra)

SUMMER 2024

EXAM SEAT NO.

--	--	--	--	--	--

LEVEL :- **First**

PROGRAM : **EE/IE/E&TC/IT**

COURSE CODE : **CCG118/CCF106**

COURSE NAME : **Engineering Mathematics**

MAX. MARKS : **80** TIME : **3 HRS.** DATE :- **10 May 2024**

Instruction :-

- 1) Answers must be written in the main answer book provided (and supplements if required).
- 2) Illustrate your answers with sketches wherever necessary.
- 3) Use of non-programmable pocket calculator is permissible.
- 4) Mathematical and other tables shall be made available on request.
- 5) Assume and mention suitable additional data if necessary.
- 6) Use of Mobile is strictly prohibited.
- 7) QN- Question No., SQN-Sub Question No. R- Remembering, U- Understanding, A- Application.

QN	S Q N	Question Text	R/ U/ A	CO	Mar ks
Q.1		Attempt any FOUR :			08
	a)	Express $\frac{2+i}{2-i}$ in the form $a+ib$	R	1	
	b)	If $(3+i)x+(1-i)y=1+7i$, Find x & y	R	1	
	c)	Find the slope and x-intercept of the straight line $\frac{x}{4}-\frac{y}{3}=2$	R	2	
	d)	Find the value of k if the lines $kx-6y=9$ and $6x+5y=13$ are perpendicular to each other.	U	2	
	e)	Find the angle between the lines $3x+2y=6$ and $2x-3y=5$	A	2	
	f)	Find the first iteration by using Jacobi's method for following system of equations. $10x+y+2z=13$, $3x+10y+z=14$, $2x+3y+10z=15$	R	3	
Q.2		Attempt any FOUR :			16
	a)	Convert into polar form $z = \frac{-1}{2} + \frac{\sqrt{3}}{2}i$	U	1	
	b)	Find the length of perpendicular from (2,3) to the line $4x-6y-3=0$	U	2	
	c)	Find the root of the equation $x^3-4x+1=0$ using Bisection method (upto 3 iterations)	A	3	
	d)	Using Regular Falsi method find the approximate root of $xe^x-3=0$ (take 3 iterations)	A	3	
	e)	Solve by Jacobi's method (3 iterations only) $10x+y+2z=13$, $3x+10y+z=14$, $2x+3y+10z=15$	A	3	
	f)	Solve the following system of equations by Gauss Seidal method $2x+y+z=4$, $x+2y+z=4$, $x+y+2z=4$	A	3	

PTO

Q.3	Attempt any FOUR :			16
a)	Simplify using DeMoivre's Theorem $\frac{(\cos 3\theta + i \sin 3\theta)^4 (\cos 5\theta - i \sin 5\theta)^4}{\left(\cos \frac{9}{2}\theta + i \sin \frac{9}{2}\theta\right)^3 \left(\cos \frac{4}{5}\theta + i \sin \frac{4}{5}\theta\right)^{10}}$	Λ	1	
b)	Find the modulus and amplitude of $z = 1 - \cos \alpha + i \sin \alpha$	Λ	1	
c)	Find the equation of line passing through the intersection of lines $4x + 3y = 8, x + y = 1$ and parallel to the line $5x - 7y = 3$	Λ	2	
d)	Find the root of equation $xe^x = 1$ by using Bisection method . (3 iterations only)	Λ	3	
e)	Solve by Jacobi's method $x + 17y - 2z = 48, 30x - 2y + 3z = 75, 2x + 2y + 18z = 30$	Λ	3	
f)	Solve the following system of equation by Gauss-seidal iteration method. $10x + 2y + z = 9, 2x + 20y - 2z = -44, -2x + 3y + 10z = 22$	Λ	3	
Q.4	Attempt any FOUR :			08
a)	If $f(x) = \sin x$ then show that $f(3x) = 3.f(x) - 4[f(x)]^3$	R	5	
b)	Evaluate $\lim_{x \rightarrow 1} \left[\frac{1}{x-1} - \frac{1}{x^2-x} \right]$	R	5	
c)	Find $\frac{dy}{dx}$ if $y = e^x \cdot \sin x$	R	6	
d)	Find $\frac{dy}{dx}$ if $y = \cos(x e^x)$	R	6	
e)	If $\tan^{-1}(x^2 + y^2) = a^2$ then find $\frac{dy}{dx}$.	U	6	
f)	At which point on the curve $y = 3x - x^2$, the slope is -5.	Λ	6	
Q.5	Attempt any FOUR :			16
a)	If $f(x) = x^2 - 3x + 4$ then find x for which $f(1-x) = f(2x+1)$	Λ	5	
b)	Evaluate $\lim_{x \rightarrow 3} \left[\frac{\sqrt{2x+3} - \sqrt{4x-3}}{x^2-9} \right]$	U	5	
c)	If $y = (\sin x)^{\cos x}$ then find $\frac{dy}{dx}$.	U	6	
d)	If $e^y = y^x$ then prove that $\frac{dy}{dx} = \frac{(\log y)^2}{\log y - 1}$.	Λ	6	
e)	If $y = e^{m \sin^{-1} x}$ then prove that $(1-x^2) \frac{d^2 y}{dx^2} - x \frac{dy}{dx} - m^2 y = 0$	Λ	6	
f)	Find the equation of tangent and normal to the curve $y = x^3 - 2x^2 + 4$ at $x = 2$	Λ	6	
Q.6	Attempt any FOUR :			16
a)	If $f(x) = \frac{x+5}{3x-4}$ & $t = \frac{5+4x}{3x-1}$ then show that $f(t) = x$	Λ	5	
b)	Evaluate $\lim_{x \rightarrow \infty} \sqrt{x^2 + x + 1} - x$	Λ	5	
c)	If $y = \sin^{-1} \left(\frac{2x}{1+x^2} \right)$ then find $\frac{dy}{dx}$.	Λ	6	
d)	If $y = x^x + 5^x + x^5 + 5^5$ then find $\frac{dy}{dx}$.	Λ	6	
e)	If $x = a(\theta + \sin \theta), y = a(1 + \cos \theta)$ then find $\frac{d^2 y}{dx^2}$ at $\theta = \frac{11}{2}$	Λ	6	
f)	Find the maximum and minimum values of $y = 2x^3 - 9x^2 + 12x + 5$	Λ	6	

GOVERNMENT POLYTECHNIC, KOLHAPUR – 416004

(An Autonomous Institute of Govt. Of Maharashtra)

SUMMER 2024**EXAM SEAT NO.**

--	--	--	--	--	--

LEVEL :- **First** PROGRAM : **CE/ME /MT**COURSE CODE : **CCG106/CCF106/X110**COURSE NAME : **Engineering Mathematics**MAX. MARKS : **80** TIME : **3 HRS.** DATE :- **10 May 2024**

Instruction :-

- 1) Answers must be written in the main answer book provided (and supplements if required).
- 2) Illustrate your answers with sketches wherever necessary.
- 3) Use of non-programmable pocket calculator is permissible.
- 4) Mathematical and other tables shall be made available on request.
- 5) Assume and mention suitable additional data if necessary.
- 6) Use of Mobile is strictly prohibited.
- 7) QN- Question No., SQN-Sub Question No. R- Remembering, U- Understanding, A- Application.

QN	S Q N	Question Text	R/ U/ A	CO	Marks
Q.1		Attempt any FOUR :			08
	a)	If $2(3-4i) + 4(2-5i) = x+iy$ then find x & y	R	1	
	b)	Show that $5x + 6y - 1 = 0$ and $6x - 5y + 3 = 0$ are perpendicular lines.	R	2	
	c)	Find the equation of straight line passing through $(4,-5)$ & having slope $-2/3$	R	2	
	d)	Two cards are drawn from a pack of cards .Find the probability that they will be both red or both pictures.	U	3	
	e)	If X is Binomially distributed with $E(X)=2$ & $\text{var.}(X)=4/3$,find the probability distribution of X .	A	4	
	f)	In a sample of 100 bulbs ,if 5% of the electric bulbs are defective ,using Poisson distribution ,find mean of the distribution.	A	4	
Q.2		Attempt any FOUR :			16
	a)	Using De'Moiver's theorem , simplify $\frac{(\cos 2\theta + i \sin 2\theta)(\cos \theta - i \sin \theta)^4}{(\cos 3\theta - i \sin 3\theta)^2 (\cos 5\theta + i \sin 5\theta)^{-3}}$	A	1	
	b)	Find the equation of a line passing through the point of intersection of the lines $2x+3y=13$, $5x-y=7$ & passing through $(1,-1)$	U	2	
	c)	Find the distance between two parallel straight lines $3x+2y-6=0$, $3x+2y-12=0$	R	2	
	d)	If the mean life time & S. D. of battery cells are 12 hrs & 3 hrs , What % of batteries will have life i) between 10& 14 hrs ii) more than 15 hrs iii) Less than 6 hrs	A	4	

	e)	Find the probability that at most 4 defective bulbs will be found in a box of 200 bulbs if it is known that 2 percent of the bulbs are defective. (Given : $e^{-4} = 0.0183$)	A	4	
	f)	A box contains 3 white & 4 black balls .Another box contains 4 white & 5black balls. If one ball is selected from each box ,what is the probability that a) two balls are of the same colour . b) Two balls are of different colours .	A	3	
Q.3		Attempt any FOUR :			16
	a)	Prove that : $(1+i)^n + (1-i)^n = 2^{n+1} \cdot \cos\left(\frac{n\pi}{4}\right)$ hence show that $(1+i)^{12} + (1-i)^{12} = -128$	A	1	
	b)	Simplify : $\frac{1+2i}{-6-i}$	U	1	
	c)	Find the length of the perpendicular from the point (2,3) on the line $4x-6y-3=0$	R	2	
	d)	A manufacture of Pins knows that on an average 5% his product is defective . He sells pins in boxes of 100 & guarantees that no more than 4 pins will be defective . In how many boxes out of 1000 ,he will meet the guaranteed quality.	A	4	
	e)	For a normal variate with mean 2.5 & standard deviation 3.5 find the probability that i) $2 \leq x \leq 4.5$ ii) $-1.15 \leq x \leq 5.5$	A	4	
	f)	If $P(A) = \frac{1}{2}, P(A \cap B) = \frac{1}{6}, P(A \cup B) = \frac{7}{12}$ find a) $P(B)$, b) $P((A' \cup B')$	A	3	

QN	S Q N	Question Text	R/ U/ A	Co CCG 106/ 118	M ar ks
Q.4		Attempt any FOUR :			08
	a)	If $f(x) = \sin x$ then show that $f(3x) = 3.f(x) - 4 [f(x)]^3$	R	5	
	b)	Evaluate $\lim_{x \rightarrow 1} \left[\frac{1}{x-1} - \frac{1}{x^2-x} \right]$	R	5	
	c)	Find $\frac{dy}{dx}$ if $y = e^x \cdot \sin x$	R	6	
	d)	Find $\frac{dy}{dx}$ if $y = \cos(x e^x)$	R	6	
	e)	If $\tan^{-1}(x^2 + y^2) = a^2$ then find $\frac{dy}{dx}$.	U	6	
	f)	At which point on the curve $y = 3x - x^2$, the slope is -5.	A	6	
Q.5		Attempt any FOUR :			16
	a)	If $f(x) = x^2 - 3x + 4$ then find x for which $f(1-x) = f(2x+1)$	A	5	
	b)	Evaluate $\lim_{x \rightarrow 3} \left[\frac{\sqrt{2x+3} - \sqrt{4x-3}}{x^2-9} \right]$	U	5	
	c)	If $y = (\sin x)^{\cos x}$ then find $\frac{dy}{dx}$.	U	6	
	d)	If $e^y = y^x$ then prove that $\frac{dy}{dx} = \frac{(\log y)^2}{\log y - 1}$.	A	6	
	e)	If $y = e^{m \sin^{-1} x}$ then prove that $(1-x^2) \frac{d^2 y}{dx^2} - x \frac{dy}{dx} - m^2 y = 0$	A	6	
	f)	Find the equation of tangent and normal to the curve $y = x^3 - 2x^2 + 4$ at $x = 2$	A	6	
Q.6		Attempt any FOUR :			16
	a)	If $f(x) = \frac{x+5}{3x-4}$ & $t = \frac{5+4x}{3x-1}$ then show that $f(t) = x$	A	5	
	b)	Evaluate $\lim_{x \rightarrow \infty} \sqrt{x^2 + x + 1} - x$	A	5	
	c)	If $y = \sin^{-1} \left(\frac{2x}{1+x^2} \right)$ then find $\frac{dy}{dx}$.	A	6	
	d)	If $y = x^x + 5^x + x^5 + 5^5$ then find $\frac{dy}{dx}$.	A	6	
	e)	If $x = a(\theta + \sin \theta)$, $y = a(1 + \cos \theta)$ then find $\frac{d^2 y}{dx^2}$ at $\theta = \frac{\pi}{2}$	A	6	
	f)	Find the maximum and minimum values of $y = 2x^3 - 9x^2 + 12x + 5$	A	6	

GOVERNMENT POLYTECHNIC, KOLHAPUR – 416004.

(An Autonomous Institute of Govt. Of Maharashtra)

SUMMER-2024**EXAM SEAT NO.**

--	--	--	--	--	--

LEVEL :- First

PROGRAM : CE/ME/MT

COURSE CODE :- CCH108

COURSE NAME :- APPLIED MECHANICS

MAX. MARKS : 70

TIME : 03 Hrs

DATE :- 11/5/2024

Instructions :-

- 1) Illustrate your answers with sketches wherever necessary.
- 2) Use of non-programmable pocket calculator is permissible.
- 3) Assume and mention suitable additional data if necessary.
- 4) Use of Mobile is strictly prohibited.
- 5) Figures are attached on separate page in question paper as per question and sub question.
- 6) QN- Question No., SQN-Sub Question No. R- Remembering, U- Understanding, A- Application.

QN	S Q N	Question Text	R/ U/ A	CO	Ma rks
Q.1		Attempt any THREE: (2 X 3)			06
	a)	Enlist any two characteristics of couple.	R	CCH111-1	
	b)	State law of polygon of forces.	R	CCH111-1	
	c)	State lami's theorem.	U	CCH111-2	
	d)	Locate centroid of a square lamina of sides 400mm, which is rested on its one corner point .	A	CCH111-2	
	e)	Define angle of repose in dry friction.	R	CCH111-3	
Q.2		Attempt any FOUR: (4 X 4)			16
	a)	A hexagon acted by six forces each side along the regular hexagon taken in clockwise order from base respectively in magnitude 1kN,2kN,3kN,4kN,5kN,6kN, determine magnitude of resultant and position of resultant.	A	CCH111-1	
	b)	Determine position of centroid of a section as shown in figure	A	CCH111-2	
	c)	A sphere weighing 1500 N is supported by two planes making angle 30° and 60° to the horizontal plane, determine support reactions.	U	CCH111-2	
	d)	A block of 300 N is at rest on 30° inclined plane, calculate horizontal force that causes the motion to impend up the plane if coefficient of friction between block and plane is 0.20	A	CCH111-3	
	e)	Determine resultant and its position from point A of force system shown in figure	U	CCH111-1	
	f)	Determine reactions of the overhang beam as shown in figure by analytical method.	A	CCH111-3	
Q.3		Attempt any TWO: (6 X 2)			12
	a)	Determine magnitude of resultant and its position from point 'A' as shown in figure	A	CCH111-1	
	b)	Determine centroid of the remainder portion after cutting a triangular notch of sides 200 mm each from the sheet as shown in figure.	U	CCH111-2	
	c)	A ladder of weight 400N, is rest on smooth wall and rough horizontal floor, making angle of 30° with vertical, if coefficient of friction in floor and ladder is 0.35 i) Draw free body diagram showing all forces ii) Find all active and reactive forces iii) state that will ladder remain stand in position ?	A	CCH111-3	

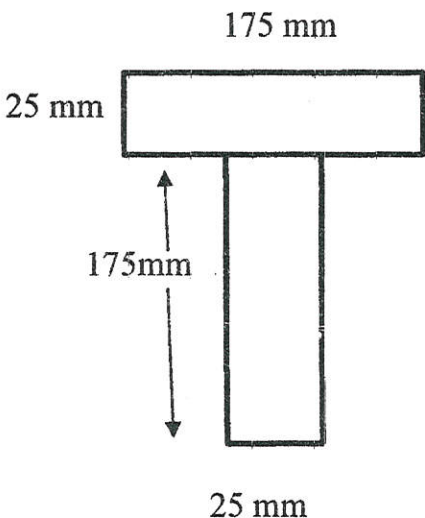
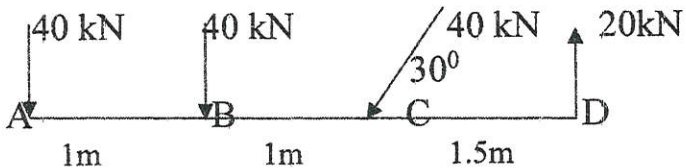
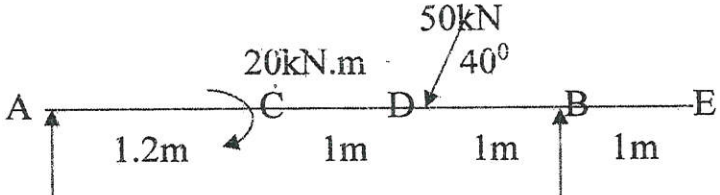
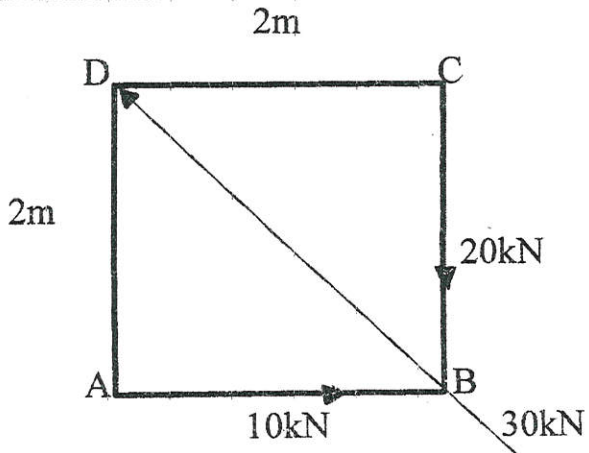
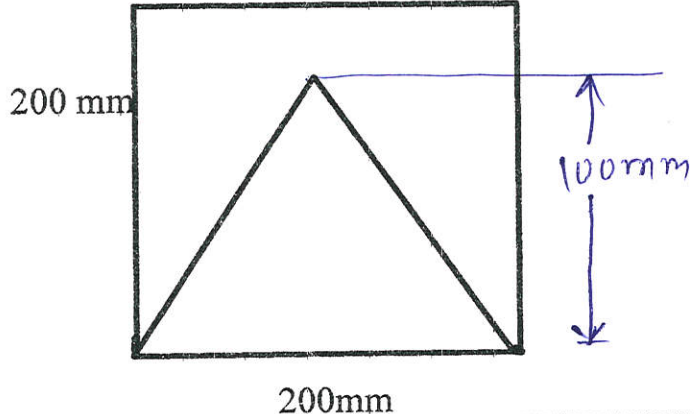
QN	S QN	figures
Q.2	b)	 <p style="text-align: center;">175 mm</p> <p style="text-align: center;">25 mm</p> <p style="text-align: center;">175 mm</p> <p style="text-align: center;">25 mm</p>
Q.2	e)	 <p style="text-align: center;">40 kN 40 kN 40 kN 20 kN</p> <p style="text-align: center;">30°</p> <p style="text-align: center;">A B C D</p> <p style="text-align: center;">1m 1m 1.5m</p>
Q.2	f)	 <p style="text-align: center;">50 kN</p> <p style="text-align: center;">20 kN.m 40°</p> <p style="text-align: center;">A C D B E</p> <p style="text-align: center;">1.2m 1m 1m 1m</p>
Q.3	a)	 <p style="text-align: center;">2m</p> <p style="text-align: center;">D C</p> <p style="text-align: center;">2m</p> <p style="text-align: center;">20 kN</p> <p style="text-align: center;">A B</p> <p style="text-align: center;">10 kN 30 kN</p>
Q.3	b)	 <p style="text-align: center;">200 mm</p> <p style="text-align: center;">200 mm</p> <p style="text-align: center;">100 mm</p>

GOVERNMENT POLYTECHNIC, KOLHAPUR – 416004.

(An Autonomous Institute of Govt. Of Maharashtra)

SUMMER 2024**EXAM SEAT NO.**

--	--	--	--	--	--

LEVEL :- First

PROGRAM : CE/ME/MT

COURSE CODE :- CCH108

COURSE NAME :- APPLIED MECHANICS

MAX. MARKS : 70

TIME : 03 Hrs

DATE :- 11 / 5 / 2024

QN	S Q N	Question Text	R/ U/ A	Co	Ma rks
Q.4		Attempt any FOUR: (2 X 4)			08
	a)	Define the ideal machine and ideal effort.	R	4	
	b)	State the D alembert's principle for dynamic equilibrium.	R	5	
	c)	Define kinetics and kinematics.	R	5	
	d)	State any two equations of rectilinear motion when a body is freely falling under gravity.	U	5	
	e)	Define P.E. and K.E. State their equations.	R	6	
	f)	State the work – energy principle.	R	6	
Q.5		Attempt any FOUR: (4 X 4)			16
	a)	State the formula of velocity ratio of differential axle and wheel with neat sketch .	R	4	
	b)	A machine requires an effort of 9N to lift a load of 45N. The velocity ratio machine is 25. Find the load lost due to friction and efficiency of the machine at this load.	U	4	
	c)	In a simple screw jack, the pitch of the screw is 10 mm and length of handle is 450mm. Find V.R. if an effort of 25N is applied at the end of handle can lift the load of 3 KN, find the efficiency of jack. Also calculate the amount of effort wasted in friction.	A	4	
	d)	If a body of mass 200 kg changes velocity of 40 m/s to 10 m/s, calculate the impulse acting on the body.	U	5	
	e)	A car has initial velocity of 3m/s. It accelerates for 12 seconds at the rate of 3.5 m/s ² . Determine the final velocity and the distance travelled during this time.	U	5	
	f)	A cubical water tank has a side of 2m each. It is placed with its base 9m above the ground level. Find the potential energy of the water tank when the tank is full.	U	6	
Q.6		Attempt any TWO: (6 X 2)			12
	a)	For a geared pulley block, the following data is available: No. of cogs on the effort wheel = 60 No. of teeth on the pinion = 10 No. of teeth on the spur = 90 No. of cogs on the load wheel = 15 If the maximum effort required to lift a load is 50N, calculate the maximum load that can be lifted by the machine at 70% efficiency.	A	4	
	b)	A bullet of weight 1N is fired with a velocity of 500 m/s horizontally in a wooden block weighing 50N resting on horizontal surface. If the bullet remains embedded in the block, calculate the velocity of the block after impact.	A	5	
	c)	A water tank of capacity 1000 liters is to be filled in 5 minutes by a pump. Water is required to be lifted through a height of 20 m. If the efficiency of the pump is 70%, find the power of pump.	A	6	

GOVERNMENT POLYTECHNIC, KOLHAPUR – 416004

(An Autonomous Institute of Govt. Of Maharashtra)

SUMMER 2024

EXAM SEAT NO.

--	--	--	--	--	--

LEVEL : - **First** PROGRAM : **COMMON**
COURSE CODE : **CCG110/CCF110**
COURSE NAME : **Applied Mechanics**

MAX. MARKS : **80** TIME : **3 HRS.** DATE :- **11 May 2024**

Instruction :-

- 1) Answers must be written in the main answer book provided (and supplements if required).
- 2) Illustrate your answers with sketches wherever necessary.
- 3) Use of non-programmable pocket calculator is permissible.
- 4) Mathematical and other tables shall be made available on request.
- 5) Assume and mention suitable additional data if necessary.
- 6) Use of Mobile is strictly prohibited.
- 7) QN- Question No., SQN-Sub Question No. R- Remembering, U- Understanding, A- Application.

QN	S Q N	Question Text	R/ U/ A	CO	Marks
Q.1		Attempt any FOUR :			08
	a)	State the characteristics of the force.	R	1	
	b)	Enlist with sketches four types of beam.	U	2	
	c)	State the principle of transmissibility of a force.	R	1	
	d)	Differentiate between resultant and equilibrant force.	U	2	
	e)	Define coefficient of Friction.	R	2	
	f)	Define Angle of static friction & dynamic friction.	R	2	
Q.2		Attempt any FOUR :			16
	a)	The four forces 10N, 20N, 15N, & 25N are acting on a point (all push type) at $0^\circ, 50^\circ, 180^\circ$ & 270° respectively. Calculate two rectangular components of each force.	A	1	
	b)	Calculate the moment about point 'B' for the force system as shown in fig No.1	A	1	
	c)	A sphere weighing 200N supported by two planes inclined at 30° and 60° to the horizontal respectively. Calculate the reactions at the plane.	A	2	
	d)	A simply supported beam of span 6m has two concentrated loads of 8KN and 10KN at 2m and 4m from left hand support, Find the reaction at the two supports.	A	2	
	e)	A block weighting 500N is resting on rough horizontal surface having $\mu=0.30$. It is just moved by a force p inclined at 25° to the horizontal. Calculate force 'P'.	A	2	
	f)	Find graphically magnitude, directions and position of the resultant force of a system of parallel unlike forces as shown in fig.2 From 'A'.	A	3	

PTO Y4

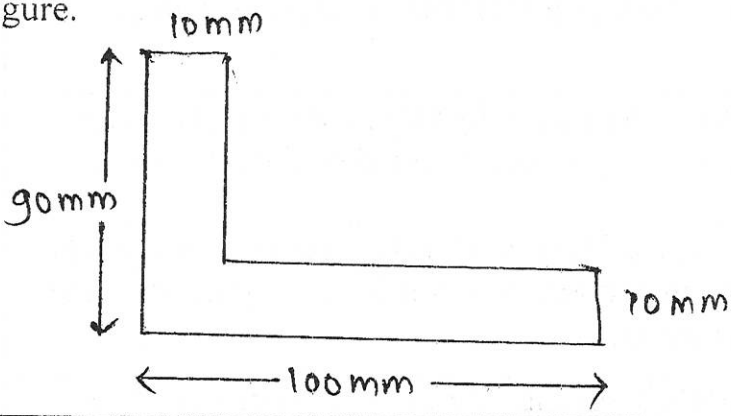
Q.3	Attempt any FOUR :			16
a)	Explain with neat sketch Law of Parallelogram of forces.	U	1	
b)	For a concurrent force system shown in fig No.3 ,Obtain magnitude and directions of it's resultant using analytical method.	A	1	
c)	For a beam ,loaded as shown in fig no. 4 .Calculate the support reactions at A & B using analytical method.	A	2	
d)	A block of weight 600N is resting on a plane inclined at 30° to the horizontal. Find the force that can be applied on the block at an angle of 25° with inclined plane so that the block is just on the point of motion up the plane, the Coefficient of friction between the body and the plane is 0.2.	A	2	
e)	A uniform ladder of weight 300N rest against a smooth vertical wall and a rough horizontal floor making an angle of 60° with the horizontal. The Coefficient of static friction at the floor is 0.30. Find reaction at wall and calculate force of friction also.	A	2	
f)	State the advantages & limitations of Graphical method .Also state the graphical condition of equilibrium for i) concurrent force system ii) Non concurrent force system.	U	3	
Q.4	Attempt any FOUR :			08
a)	Define Centroid.	R	4	
b)	A equilateral triangle of sides 400mm is rested on the base then locate centroid.	A	4	
c)	Calculate angular velocity of a minute hand of clock.	A	5	
d)	Define energy & state its unit.	R	5	
e)	Define ideal machine.	R	6	
f)	If law of machine is $P = 0.25w + 2N$, then state meaning of each term of this law.	U	6	
Q.5	Attempt any TWO :			16
a)	Determine centroid of the following figure & locate in the figure. 	A	4	
b)	A motor car moving with uniform acceleration passes distance 100m, at start velocity was 45kmph & at the point when it reaches 100m was 54kmph, then find i) acceleration of the car ii) time taken to travel 100m iii) number of revolutions made by the wheels of the car during it's travel of 100m ,diameter of wheel is 500mm. iv) distance travelled in the 2 minutes from the start, if same uniform acceleration.	A	5	

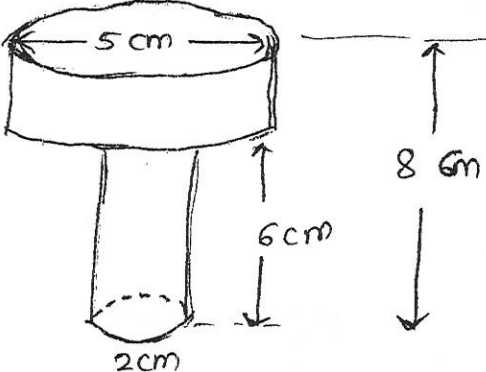
	<p>c) In a simple lifting machine 1.5kw effort is to be moved through a distance of 7.2 m & load 24KN through distance 0.300m ,then determine i) Mechanical advantage ii) velocity ratio ii)efficiency in % iv) ideal effort v) effort lost in friction vi) load lost in friction vii) ideal load viii) state machine is reversible or not?</p>	A	6							
Q.6	Attempt any TWO :			16						
	<p>a) Determine center & gravity of the body as shown in the figure.</p> 	A	4							
	<p>b) i) A disc rotating at 30rps retards uniformly & rotates at 15rps on completing 540 revolutions .Find the time taken & the angular retardation. ii) A cube of size 1m X 1m X 1m weights 500N is displaced by 3 meter by toppling of cube , then calculate it's work done.</p>	A	5							
	<p>c) In a lifting machine observations are as the follows</p> <table border="1" data-bbox="256 1400 505 1538"> <tr> <td>Load</td> <td>effort</td> </tr> <tr> <td>3000N</td> <td>400N</td> </tr> <tr> <td>5000N</td> <td>640N</td> </tr> </table> <p>ii) Velocity ratio = 16</p> <p>then determine i) Law of machine ii) How much load can be lifted with an effort of 760N? iii) Maximum efficiency & maximum mechanical advantage . iv) If suddenly effort is removed then whether the load comes down or not?</p>	Load	effort	3000N	400N	5000N	640N	A	6	
Load	effort									
3000N	400N									
5000N	640N									

P.T.O. 3/4

fig No 1
 Q. NO 2 (b)

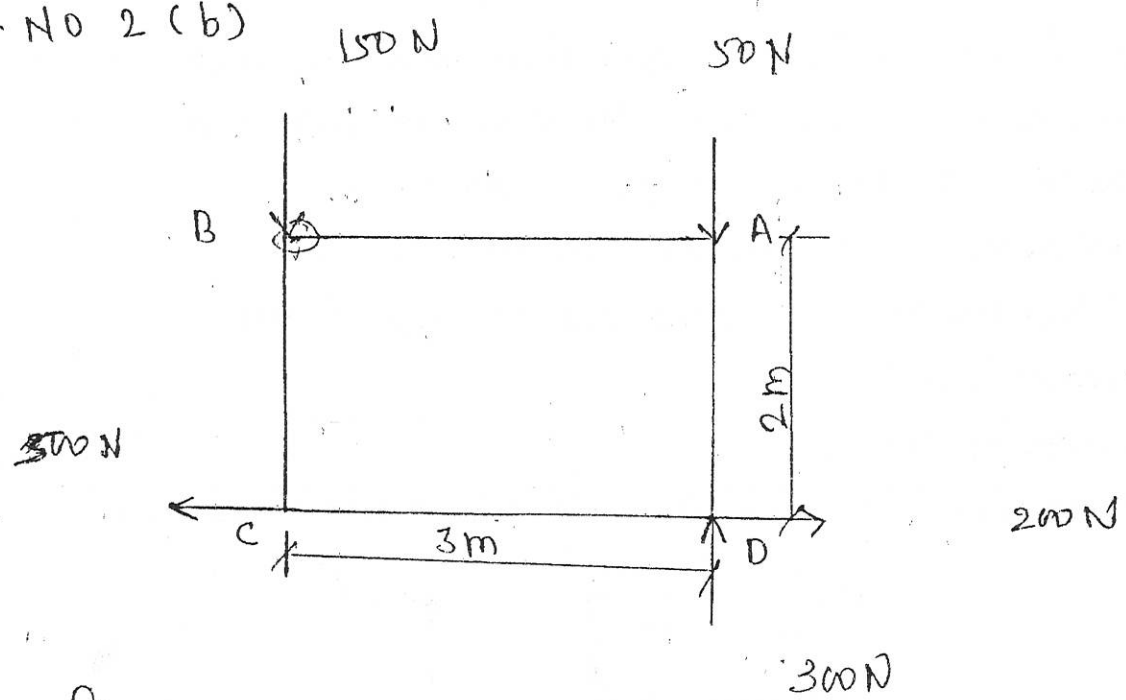

fig No 2
 Q. NO 2 (f).

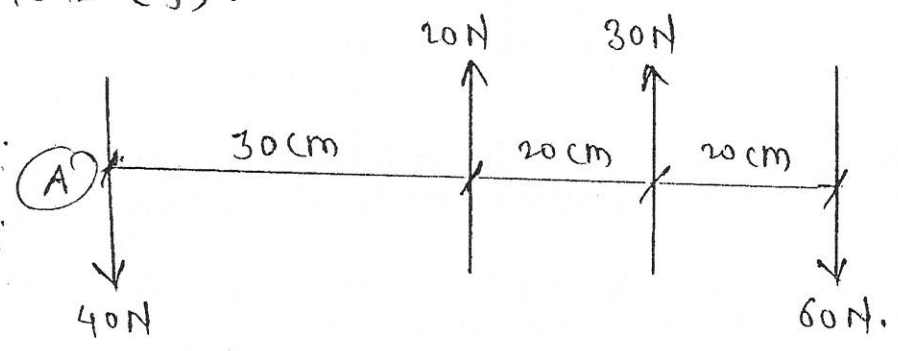

fig No 3
 Q 3 (b).

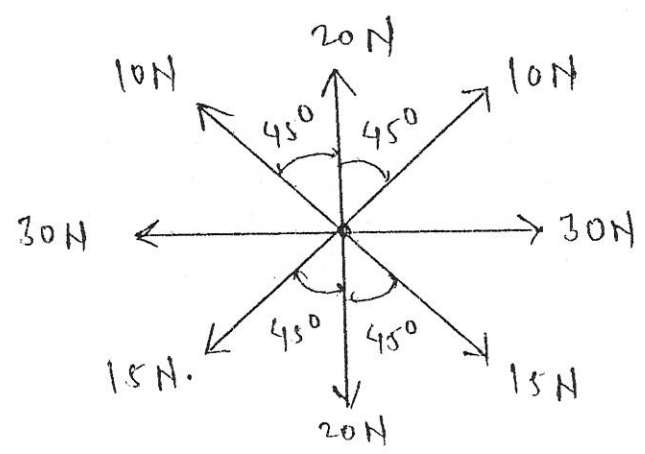
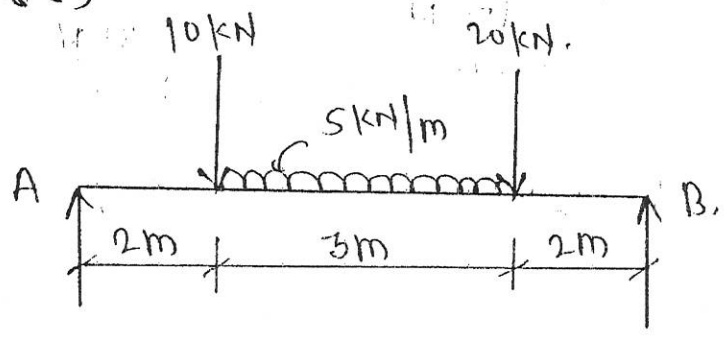

fig No-4
 Q 3 (c)



GOVERNMENT POLYTECHNIC, KOLHAPUR – 416004.

(An Autonomous Institute of Govt. Of Maharashtra)

EVEN TERM END EXAM SUMMER -2024**EXAM SEAT NO.**

--	--	--	--	--	--

LEVEL :- **FIRST**PROGRAM : **CE/ME/MT**COURSE CODE :- **CCG107/CCF107**COURSE NAME **ENGINEERING DRAWING - I**MAX. MARKS : **80** TIME : **04Hrs.**DATE :- **22/05/2024**

Instruction :-

- 1) Answers must be written in the main answer book provided.(and supplements if required)
- 2) Illustrate your answers with sketches wherever necessary.
- 3) Use of non-programmable pocket calculator is permissible.
- 4) Mathematical and other tables shall be made available on request.
- 5) Assume and mention suitable additional data if necessary.
- 6) Use of Mobile is strictly prohibited.
- 7) QN- Question No., SQN-Sub Question No. R- Remembering, U- Understanding, A- Application.

QN	S Q N	Question Text	R/ U/ A	Co CCG 107	Mar ks
Q.1		Attempt any TWO :			08
	a)	Construct a scale 1:50 to read upto 6 meters in meters and decimeters. Show on it a distance 4.9 meters.	R & U	1	4
	b)	Draw a neat sketch showing aligned system of dimensioning and unidirectional system of dimensioning.	R & U	1	4
	c)	Illustrate with neat sketch cutting plane line and hidden line.	R & U	1	4
Q.2	a)	Attempt any TWO :			12
	i)	Draw the involute of a pentagon having each side of length 20mm.	U & A	2	06
	ii)	A circle of 60mm diameter rolls outside and along another fixed circle of 160mm diameter. Draw an epicycloid for one complete revolution of the rolling circle.	U & A	2	06
	iii)	Distance between two fixed points F_1 and F_2 is 80mm. Point P moves in such a way that the difference between its distances from F_1 and F_2 is always constant and is equal to 50mm. Trace the curve by point 'P'.	A & A	2	06
	b)	Attempt any TWO :			08
	i)	Construct an ellipse when its major axis is 100mm and minor axis is 70mm by using concentric circle method.	U& A	2	04
	ii)	Draw a parabola having base length 80mm and axis height 50mm by the rectangle method.	U& A	2	04
	iii)	Draw a helix of one convolution when diameter of the cylinder is 60mm and pitch is 40mm.	U& A	2	04
Q.3		Attempt any TWO :			12
	a)	A line AB of length 75mm has its end 'A' 10mm above H.P. Line is parallel to V.P. and 20mm in front of it, plan length is 50mm. Draw the projections of lone AB.	R & U	3	06

P.T.O

Y4

b)	A line AB of length 70mm has its end 'A' 10mm in front of V.P. Line is parallel to H.P. and 30mm above it. Draw projections of line AB when elevation length is 55mm. Find inclination of line with V.P.	R & U	3	
c)	A straight line of true length 70mm has its end A on the H.P. and 20mm in front of V.P. Line is parallel to V.P. and inclined 40° to the H.P. Draw plan length of line.	R & U	3	

P.T.O. 2/4

GOVERNMENT POLYTECHNIC, KOLHAPUR – 416004.

(An Autonomous Institute of Govt. Of Maharashtra)

SUMMER- 2024

EXAM SEAT NO.

--	--	--	--	--	--

LEVEL :- *First*

PROGRAM : *CE|ME|MT*

COURSE CODE: - CCG107

COURSE NAME :- ENGINEERING DRAWING -I

MAX. MARKS : 80 TIME : 04 Hrs DATE :- *22/5/2024*

Instruction :-

- 1) Answers of two sections must be written in separate section answer book provided.
- 2) Illustrate your answers with sketches wherever necessary.
- 3) Use of non-programmable pocket calculator is permissible.
- 4) Mathematical and other tables shall be made available on request.
- 5) Assume and mention suitable additional data if necessary.
- 6) Use of Mobile is strictly prohibited.
- 7) QN- Question No., SQN-Sub Question No. R- Remembering, U- Understanding, A- Application.

QN	S Q N	Question Text	R/ U/ A	CO	Ma rks
Q.4		Attempt any TWO :			12
	a)	A pentagonal plate of 40 mm side is resting on one of its sides on HP such that plate is inclined at 40° with HP and perpendicular to VP. The center of plate is 50 mm from VP. Draw three views of pentagonal plate.	U	4	6
	b)	A rectangular plate having smallest side 40 mm and longest side 60 mm is kept on the HP on its smaller side with surface perpendicular to V.P. It is inclined to HP in such a way that top view appears as a square. Draw three views and find inclination of plane with HP.	U	4	6
	c)	A hexagonal plate of side 30 mm has a corner is VP and its surface making 40° to VP and perpendicular to HP. Draw its three views.	U	4	6
Q.5		Attempt any ONE :			14
	a)	Figure No-01 shows pictorial view of an object. Draw following views (i) Front view looking in the direction X (ii) Top view	U	5	8 6
	b)	Figure No-02 shows pictorial view of an object. Draw following views (i) Front view looking in the direction X (ii) Side view looking in the direction Y	U	5	8 6
Q.6		Attempt any ONE :			14
	a)	A pictorial view of an object is shown in Fig.No.3. Draw (using first angle method). (i) Sectional front view in x-direction (Along the cutting plane A-A) (ii) Top view	U	5	8 6
	b)	A pictorial view of an object is shown in Fig. No.4, Draw the following. (i) Sectional front view, along section P-Q (ii) Left Hand Side view.	U	5	8 6

P. T. O. 3/4

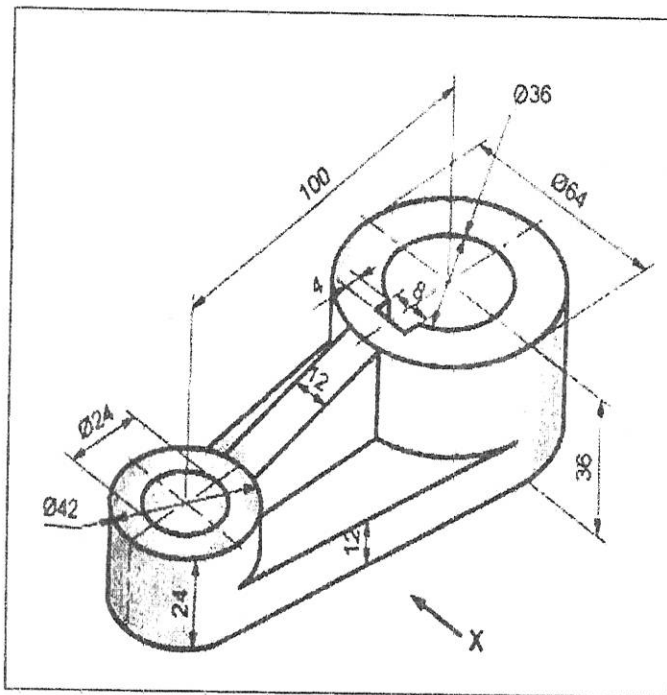

Q-5-A-FIG NO-01

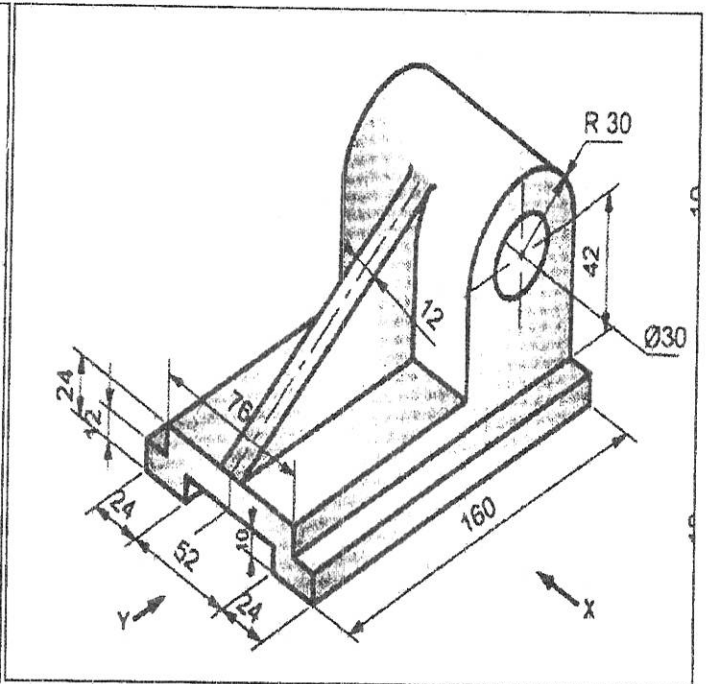

Q-5-B-FIG NO-02

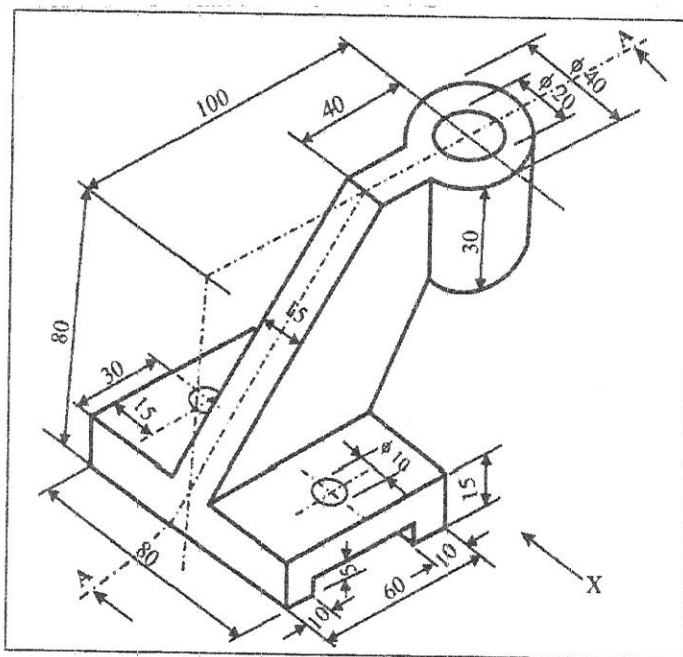

Q-6-A-FIG NO-03

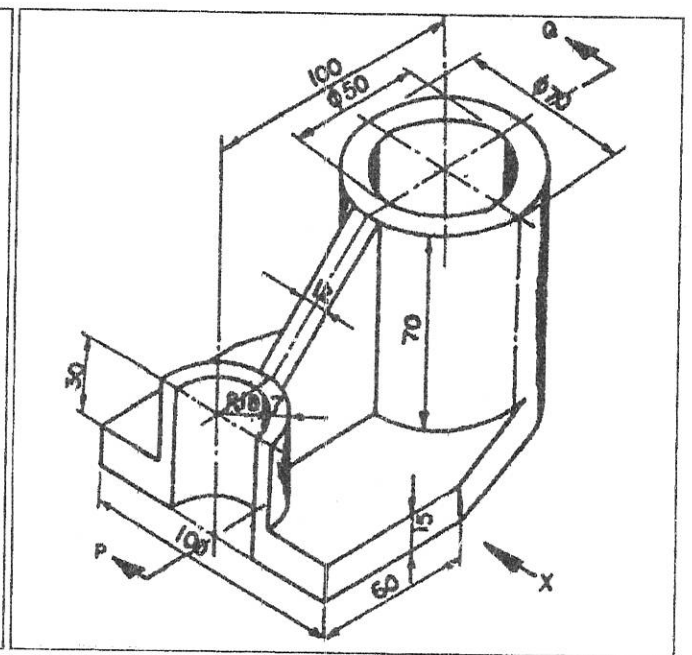

Q-6-B-FIG NO-04

GOVERNMENT POLYTECHNIC, KOLHAPUR – 416004.

(An Autonomous Institute of Govt. Of Maharashtra)

SUMMER 2024**EXAM SEAT NO.**

--	--	--	--	--	--

LEVEL: - First

PROGRAM: (ME/CE/MT)

COURSE CODE: - CCH106

COURSE NAME: - ENGINEERING GRAPHICS

MAX. MARKS: 70

TIME: 04 Hrs

DATE: -22/5/2024

Instruction :-

- 1) Answers of two sections must be written in separate section answer book provided.
- 2) Illustrate your answers with sketches wherever necessary.
- 3) Use of non-programmable pocket calculator is permissible.
- 4) Mathematical and other tables shall be made available on request.
- 5) Assume and mention suitable additional data if necessary.
- 6) Use of Mobile is strictly prohibited.
- 7) QN- Question No., SQN-Sub Question No. R- Remembering, U- Understanding, A- Application.

QN	S Q N	Question Text	R/ U/ A	Co CCH 107-	Ma rks
Q.1		Attempt any THREE: (3 X 2M)			06
	a)	Draw conventions of the following lines i) Hidden line ii) Long break line	R	1	
	b)	Calculate Length of Scale if RF is 1:40 and maximum length to be measured is 5 meters.	A	1	
	c)	Draw aligned and unidirectional dimensioning system	A	1	
	d)	Draw pentagon of side 30mm by geometric construction method.	A	1	
Q.2		Attempt any THREE: (3 X 6 M)			18
	a)	Draw an ellipse having major and minor axes 120 mm and 70 mm respectively by concentric circles method	U	2	
	b)	A fixed-point F is 80 mm from a fixed straight line AB. Draw parabola by directrix focus method.	U	2	
	c)	A point P is 55 mm and 35 mm away from two fixed straight lines, which are at right angles to each other. Draw the rectangular hyperbola through point P within 15 mm distance from each line.	A	2	
	d)	Draw helix on a cylinder of 50 mm diameter of one turn, given pitch equal to 40 mm.	A	2	
Q.3		Attempt any TWO: (2 X 5M)			10
	a)	A line AB of length 65 mm has its end A 20 mm from both the reference planes. Line is parallel to V.P. and inclined at 35° to the H.P. Draw three views of the line and find its plan length.	U	3	
	b)	End A and B of a line AB is 15 mm and 55 mm respectively in front of the V.P. Elevation length of the line is 60 mm and it is parallel to the XY line and 15 mm above it. Draw three views of the line and find its true length and inclination with V.P.	U	3	
	c)	A straight line AB of length 70 mm has its end A on the HP and 30 mm in front of the V.P. Line is parallel to V.P. and inclined at 45° to the H.P. Draw three views of the line AB and find distance of end B from H.P. and length of the plan.	U	3	

P.T.O.

GOVERNMENT POLYTECHNIC, KOLHAPUR – 416004.

(An Autonomous Institute of Govt. Of Maharashtra)

SUMMER 2024**EXAM SEAT NO.**

--	--	--	--	--	--

LEVEL :- First

PROGRAM : ME/CE/MT

COURSE CODE :- CCH106

COURSE NAME:-ENGINEERING GRAPHICS

MAX. MARKS: 70

TIME : 04 Hrs.

DATE :- 22/5/2024

QN	S Q N	question text	R/ U/ A	Co	Ma rks
Q.4		Attempt any TWO: (5M X 2)			10
	a)	A thin hexagonal plate , 25mm side is resting on a corner in the H.P. with its surface perpendicular to H.P. and inclined at 45° to V.P. Draw its projections when two sides are perpendicular to V.P.	U	107-4	5
	b)	A Circular plate of negligible thickness of 50mm diameter has a point on its circumference in V.P. its surface is perpendicular to H.P. and inclined to V.P. such that front view appears as an ellipse with minor axis 35mm. Draw its projections and find the inclination of the plate with V.P.	U	107-4	5
	c)	A thin pentagonal plate ABCDE, 25mm side, has a side AB parallel to V.P. and 15mm away from it. Draw its views, when its surface is perpendicular to H.P. and inclined at 30° to V.P.	U	107-4	5
Q.5		Attempt any ONE: (14 M X 01)			14
	a)	Figure No-01 Shows the pictorial view of an object. Using first angle method Draw 1) Front View looking in the direction-X 2) Side View from Left	U	107-5	7 7
	b)	Figure No-02 Shows the pictorial view of an object. Using first angle method Draw 1) Front View looking in the direction-X 2) Top View	U	107-5	7 7
Q.6		Attempt any ONE: (12M X 01)			12
	a)	Figure No-03 Shows the pictorial view of an object. Using first angle method Draw 1) Sectional Front View looking in the direction-X along sect-A-A 2) Top View	U	107-5	6 6
	b)	Figure No-04 Shows the pictorial view of an object. Using first angle method Draw 1) Sectional Front View looking in the direction-X along sect-A-A 2) Top View	U	107-5	6 6

P.T.O.

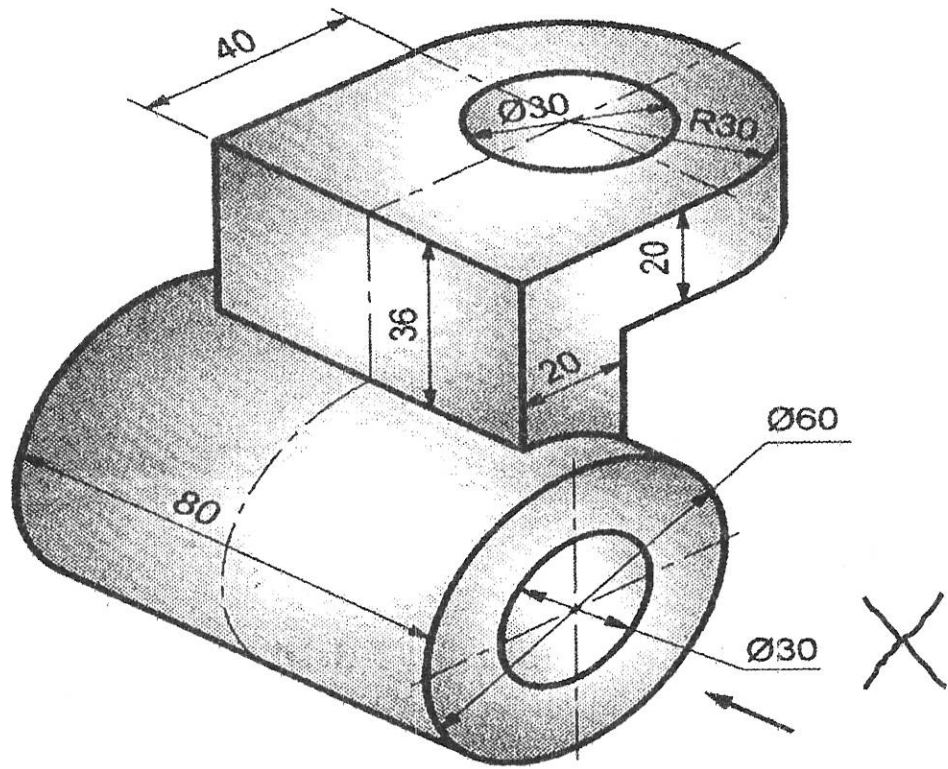

FIGURE NO-01

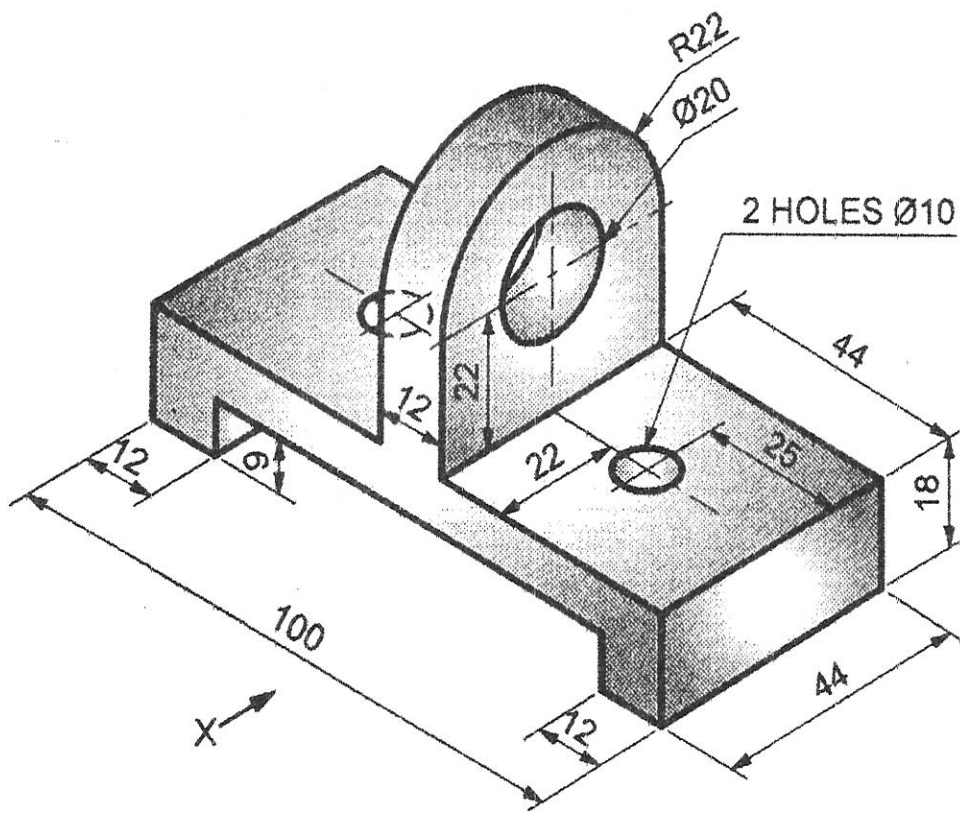

FIGURE NO-02

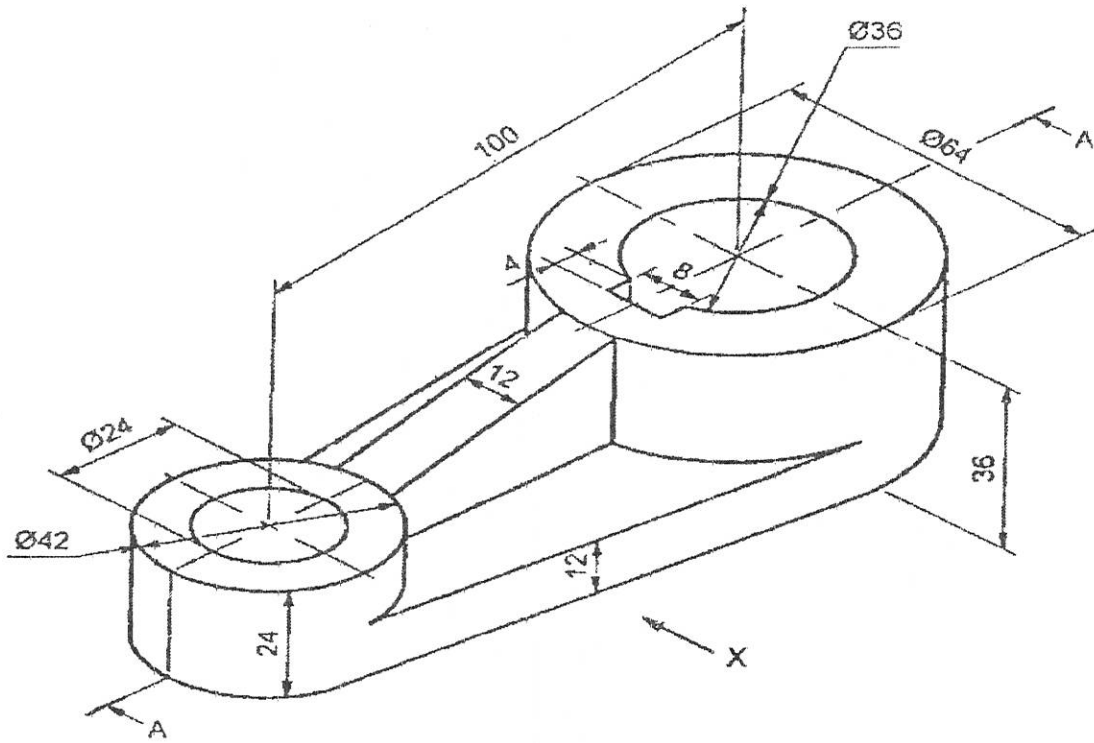

FIGURE NO-03

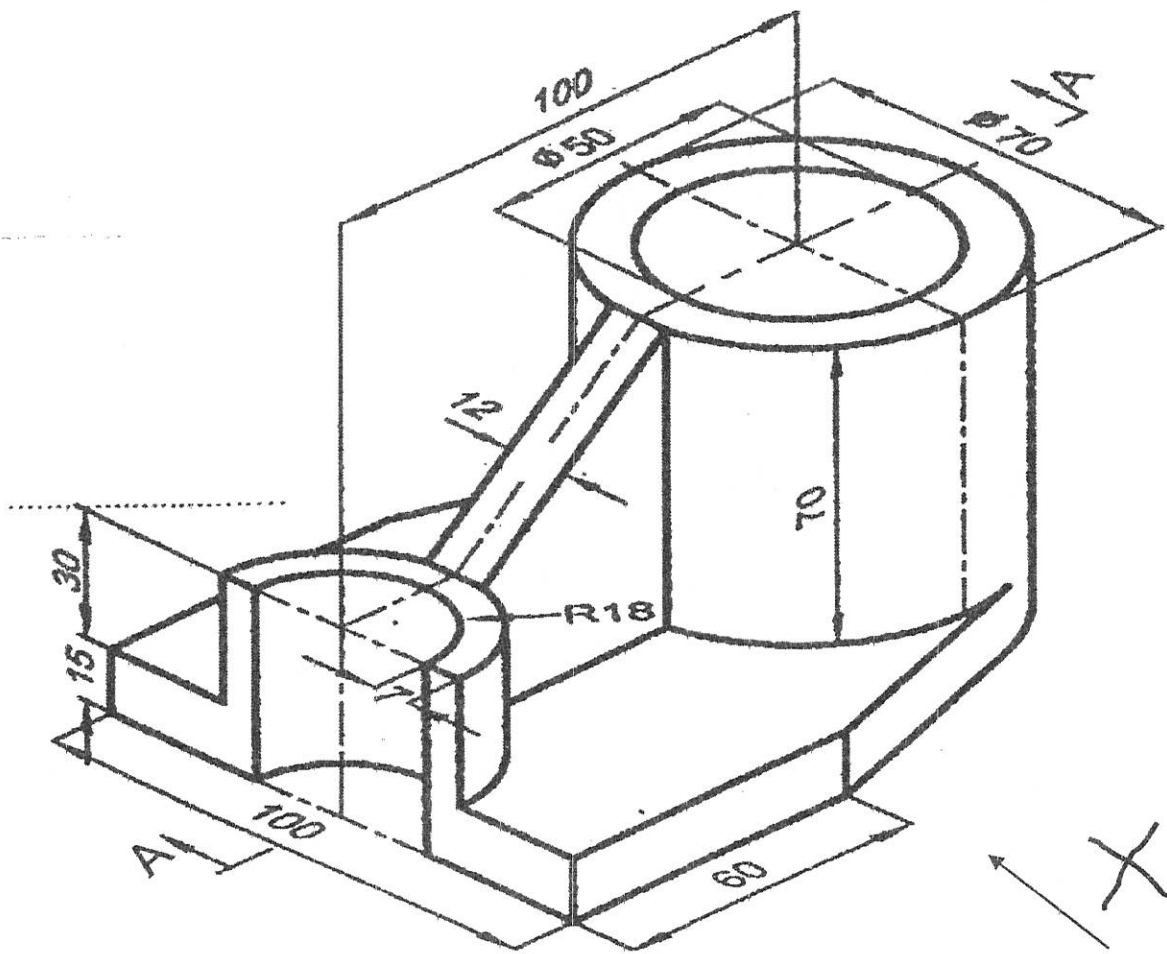

FIGURE NO-04

*** **

GOVERNMENT POLYTECHNIC, KOLHAPUR – 416004.

(An Autonomous Institute of Govt. Of Maharashtra)

EVEN TERM END EXAM SUMMER -2024**EXAM SEAT NO.**

--	--	--	--	--	--

LEVEL :- **FIRST**PROGRAM : **EE / IE / IT / E& TC**COURSE CODE :- **CCG102 / CCF102**COURSE NAME **ENGINEERING PHYSICS**MAX. MARKS : **80** TIME : **03Hrs.**DATE :- **22/05/2024**

Instruction :-

- 1) Answers must be written in the main answer book provided.(and supplements if required)
- 2) Illustrate your answers with sketches wherever necessary.
- 3) Use of non-programmable pocket calculator is permissible.
- 4) Mathematical and other tables shall be made available on request.
- 5) Assume and mention suitable additional data if necessary.
- 6) Use of Mobile is strictly prohibited.
- 7) QN- Question No., SQN-Sub Question No. R- Remembering, U- Understanding, A- Application.

QN	S Q N	Question Text	R/ U/ A	Co CCG 102	Mar ks
Q.1		Attempt any FOUR :			08
	a)	State any two fundamental physical quantities and write their SI units.	R	1	
	b)	Classify following into fundamental and derived SI units: kg, A, N, m/s.	U	1	
	c)	Write any two points regarding significance of factor of safety.	A	2	
	d)	Define velocity gradient and write its unit.	R	2	
	e)	State any two applications of viscosity.	A	2	
	f)	State any two characteristics of SHM.	R	3	
Q.2		Attempt any FOUR :			16
	a)	The length of a wire is expressed in four ways as 0.00350km, 3.50m, 350cm and 3500mm. Find the number of significant figures in each case.	A	1	
	b)	Define i) Deforming force ii) Restoring force iii) Stress iv) strain.	R	2	
	c)	A wire of length 3m and cross-sectional area $0.78 \times 10^{-4} \text{ m}^2$ extends by 0.003m. When loaded with a mass of 150kg. Calculate Young's modulus. (Take : $g = 9.8 \text{ m/s}^2$)	A	2	
	d)	State and explain Newton's Law of viscosity. Hence define coefficient of viscosity.	U	2	
	e)	State any four characteristics of transverse wave.	U	3	
	f)	Give reasons for following : i) Soldiers are asked to break their steps while crossing a bridge. ii) Radio receiver is tuned to a particular frequency.	U	3	
Q.3		Attempt any FOUR :			16
	a)	State any four requirements of good unit.	U	1	
	b)	The mass of an object is measured as 37.6gm by a weighing machine of least count 0.02gm. Estimate percentage error in measurement.	A	1	
	c)	Classify following into elastic body and plastic body: Clay, Rubber, Steel, Mud, Wax, Glass, Copper and Aluminium.	U	2	
	d)	Obtain formula for coefficient of viscosity by Stoke's method.	A	2	

P.T.O.

	e)	Define : i) Periodic motion ii) SHM iii) Period iv) Frequency	R	3	
	f)	Distinguish between free and forced vibrations (any four points)	U	3	
Q.4		Attempt any FOUR:			08
	a)	Give any two advantages of optical fiber.	U	6	
	b)	Define specific resistance. Give its unit.	R	4	
	c)	State any two properties of X-rays.	R	5	
	d)	Define nanoscale and nanoparticle.	R	5	
	e)	State Ohms law. Give unit of resistance.	R	4	
	f)	State the principle of optical fiber.	R	6	
Q.5		Attempt any FOUR:			16
	a)	State and explain properties of laser.	U	5	
	b)	State and prove series law of resistances.	A	4	
	c)	Give any four applications of optical fiber.	U	6	
	d)	Derive Prism Formula for refractive index.	A	4	
	e)	Give any four applications of nanotechnology.	U	5	
	f)	Find the effective resistance if four resistances of 2Ω each are connected in parallel.	A	4	
Q.6		Attempt any FOUR:			16
	a)	Describe how X-ray are produced by using Coolidge tube.	A	5	
	b)	Define refraction of light. State Snell's law of refraction.	R	4	
	c)	Explain stimulated emission of laser, with neat diagrams.	U	5	
	d)	Derive the balancing condition of Wheatstone's network.	A	4	
	e)	Explain structure of optical fiber with the help of neat labelled diagram.	U	6	
	f)	The equilateral glass prism under minimum deviation condition has an angle of incidence 40° . Find its refractive index.	A	4	

GOVERNMENT POLYTECHNIC, KOLHAPUR – 416004.

(An Autonomous Institute of Govt. Of Maharashtra)

EVEN TERM END EXAM SUMMER -2024**EXAM SEAT NO.**

--	--	--	--	--	--

LEVEL :- **FIRST**PROGRAM : **CIVIL/MECHANICAL/METALLURGICAL ENGG.**COURSE CODE :- **CCG101/CCF101**COURSE NAME **ENGINEERING PHYSICS**MAX. MARKS : **80** TIME : **03Hrs.** DATE :- **22/05/2024**

Instruction :-

- 1) Answers must be written in the main answer book provided.(and supplements if required)
- 2) Illustrate your answers with sketches wherever necessary.
- 3) Use of non-programmable pocket calculator is permissible.
- 4) Mathematical and other tables shall be made available on request.
- 5) Assume and mention suitable additional data if necessary.
- 6) Use of Mobile is strictly prohibited.
- 7) QN- Question No., SQN-Sub Question No. R- Remembering, U- Understanding, A- Application.

QN	S Q N	Question Text	R/ U/ A	Co EEG 101	Mar ks
Q.1		Attempt any FOUR :			08
	a)	Define i) elastic limit ii) Strain.	R	2	
	b)	Define fundamental quantity and derived quantity.	R	1	
	c)	State any two applications of viscosity.	A	2	
	d)	State any two characteristics of linear S.H.M.	U	3	
	e)	Explain Stoke's Law of viscosity.	U	2	
	f)	Define i) Periodic motion ii) SHM.	R	3	
Q.2		Attempt any FOUR :			16
	a)	Explain the Young's modulus, Bulk modulus and modulus of rigidity. Give the relation between them.	U	2	
	b)	Derive an expression for coefficients of viscosity using Stoke's method.	A	2	
	c)	Define i) Amplitude of SHM ii) Period of SHM iii) Frequency of SHM iv) Phase of SHM.	R	3	
	d)	Write the significant figures for the following : i) 0.043 ii) 4.03×10^8 iii) 0.0730 iv) 3.720.	A	1	
	e)	Explain the system of units – CGS, MKS.	U	1	
	f)	Define free and forced oscillations. Give one example of each.	R	3	
Q.3		Attempt any FOUR :			16
	a)	Define i) Viscosity ii) terminal Velocity iii) Velocity Gradient iv) Coefficient of Viscosity.	R	2	
	b)	A weight exerts force of 100 N on a steel wire of diameter 0.4mm. Find the extension produced in the wire, if original length of wire is 5m. (Given $Y = 2 \times 10^{12} \text{ N/m}^2$)	A	2	
	c)	Mention any four characteristics of transverse wave.	U	3	
	d)	Explain random error, instrumental error with one example of each.	U	1	
	e)	Find the change in volume of 2 litre of liquid due to change in pressure of 10^7 N/m^2 if bulk modulus of liquid is $1.67 \times 10^{11} \text{ N/m}^2$.	A	2	
	f)	Explain the phenomenon of Resonance and any two applications of resonance. <i>→state</i>	U	3	

P.T.O

QN	S Q N	Question Text	R/ U/ A	Co CCG 101	M ar ks
Q.4		Attempt any FOUR :			08
	a)	State and explain Ohm's Law.	U	4	
	b)	Write full form of LASER.	R	5	
	c)	Define i) Nano meter ii) Nano particle.	R	5	
	d)	State the principle of production of X-rays.	R	5	
	e)	Define i) Echo ii) Reverberation.	R	6	
	f)	State any two applications of ultrasonic waves.	R	6	
Q.5		Attempt any FOUR :			16
	a)	Derive formula for effective resistance of a series combination of resistances.	A	4	
	b)	Explain the refraction of light through a glass prism using ray diagram.	U	4	
	c)	State and explain properties of laser.	U	5	
	d)	State applications of nanotechnology in the field of electronics and textile (two each)	A	5	
	e)	For an equilateral prism the angle of minimum deviation is 30° . Find the refractive index of the prism.	A	4	
	f)	Calculate the specific resistance of wire 6m in length, 0.4mm in diameter and having a resistance of 30Ω .	A	4	
Q.6		Attempt any FOUR :			16
	a)	Derive the prism formula.	A	4	
	b)	Explain population inversion with the help of neat diagram.	U	5	
	c)	With the help of neat diagram, explain the construction of X-ray Coolidge tube.	R	5	
	d)	Explain any one method of production of ultrasonic waves.	U	6	
	e)	When a resistance of 15Ω is connected in the right gap of a meter bridge, the null point is obtained at 40cm from the left end. Find The resistance in the left gap.	A	5	
	f)	The volume of a hall is 8000m^3 and reverberation time is 2 sec. If the absorbing surface of the hall is 6400m^2 . Determine the coefficient of absorption.	A	6	

GOVERNMENT POLYTECHNIC, KOLHAPUR – 416004.

(An Autonomous Institute of Govt. Of Maharashtra)

SUMMER- 2024

EXAM SEAT NO.

--	--	--	--	--	--

LEVEL: - First

PROGRAM: Common

COURSE CODE: - CCH201

COURSE NAME: - Communication Skills

MAX. MARKS: 70

TIME: 03 Hrs

DATE: -24/5/2024

Instruction: -

- 1) Answers of two sections must be written in separate section answer book provided.
- 2) Illustrate your answers with sketches wherever necessary.
- 3) Use of non-programmable pocket calculator is permissible.
- 4) Mathematical and other tables shall be made available on request.
- 5) Assume and mention suitable additional data if necessary.
- 6) Use of Mobile is strictly prohibited.
- 7) QN- Question No., SQN-Sub Question No. R- Remembering, U- Understanding, A- Application.

QN	S Q N	Question Text	R/ U/ A	Co CCH10 6	Ma rks
Q.1		Attempt any THREE: (2 X 3)			06
	a)	Write any two examples of homophones. (Pairs.)	R	1	
	b)	Write meaningful words with the help of following suffixes: (-ness, -ment, -ly, -y.)	U	1	
	c)	Define Downward Communication.	R	2	
	d)	Why group discussion is conducted in an interview?	U	3	
	e)	Disadvantages of Oral Communication	R	3	
Q.2		Attempt any FOUR: (4 X 4)			16
	a)	Write a note on Collocation.	R	1	
	b)	“Communication is a two-way process “Elucidate it with the help of examples.	U	2	
	c)	Discuss basic principles of effective communication.	A	2	
	d)	Characteristics of Oral Communication.	R	2	
	e)	Write a note on the significance and role of communication in society.	U	2	
	f)	Explain in detail various barriers to communication.	R	3	
Q.3		Attempt any TWO: (6 X 2)			12
	a)	Explain the advantages and disadvantages of written communication.	R	2	
	b)	What do you understand by non-verbal communication?	R	2	
	c)	Essential Ways to Overcome Communication Barriers. Explain.	U	3	

P.T.O.

GOVERNMENT POLYTECHNIC, KOLHAPUR -416004
(An Autonomous Institute of Govt. of Maharashtra)
SUMMER-2024

EXAM SEAT NO-

--	--	--	--	--	--

LEVEL- FIRST

PROGRAM-COMMON

COURSE CODE- CCH201

COURSE NAME- COMMUNICATION SKILLS

MAX MARKS- 70

TIME- 03 Hrs.

DATE- 24/5/2024

QN.	S Q N	Question Text	R/ U/ A	CO CCH10 6	Mark																		
Q.4		Attempt any FOUR: (2X4)			08																		
	a)	List down at least four advantages of written communication	R	4																			
	b)	Define the term 'Proxemics' with one example.	R	5																			
	c)	State the demerits of using OHP for presentation.	R	6																			
	d)	State the meaning of the term- 'Vocalics'.	R	5																			
	e)	Enlist the various advantages of using graphical communication for formal situation.	R	4																			
	f)	Explain the meaning of term-'Posture'.	R	5																			
Q.5		Attempt any FOUR: (4X4)			16																		
	a)	Explain the importance of proper eye contact.	U	5																			
	b)	Illustrate with one example the importance of grooming for engineering student.	U	5																			
	c)	Explain the usefulness of Dairy-writing for a professional person.	U	4																			
	d)	Provide the possible Precautions to be taken for Power Point Presentation.	U	6																			
	e)	Explain the given statement here 'Reading makes a full man, Conference a ready man and writing an exact man.'	U	4																			
	f)	Illustrate the positive Posture at work place.	U	5																			
Q.6		Attempt any TWO:(6X2)			12																		
	a)	Your department wants to buy electric equipment for use. Design a suitable letter of enquiry from your department requesting the local dealer to send you price list, catalogue in a week. While designing the letter consider yourself as Manager of the Department and send this document to M/S, Bharat Heavy Electrical Supplier, Rajarampuri, 4th Lane, Kolhapur.	A	5																			
	b)	In an automobile factory of your M.I.D.C., You have been working as a Unit in-charge of manufacturing section. This month there is a shortage of production. So draft a fall in Production report of this and address the report to –The General Manager, Administration Department.	A	5																			
	c)	A state level presentation competition was held to celebrate the 'Engineer's day' in your polytechnic. The course wise response of the students was given here. Using the given data, prepare a bar graph to represent this information.	A	4																			
		<table border="1" style="width: 100%; border-collapse: collapse;"> <thead> <tr> <th style="width: 10%;">Sr. No.</th> <th style="width: 50%;">Course Name</th> <th style="width: 40%;">No. of student participated</th> </tr> </thead> <tbody> <tr> <td style="text-align: center;">1</td> <td>Electronics Engineering</td> <td style="text-align: center;">16</td> </tr> <tr> <td style="text-align: center;">2</td> <td>Computer Engineering</td> <td style="text-align: center;">14</td> </tr> <tr> <td style="text-align: center;">3</td> <td>Civil Engineering</td> <td style="text-align: center;">12</td> </tr> <tr> <td style="text-align: center;">4</td> <td>Mechanical Engineering</td> <td style="text-align: center;">16</td> </tr> <tr> <td style="text-align: center;">5</td> <td>Electrical Engineering</td> <td style="text-align: center;">18</td> </tr> </tbody> </table>	Sr. No.	Course Name	No. of student participated	1	Electronics Engineering	16	2	Computer Engineering	14	3	Civil Engineering	12	4	Mechanical Engineering	16	5	Electrical Engineering	18			
Sr. No.	Course Name	No. of student participated																					
1	Electronics Engineering	16																					
2	Computer Engineering	14																					
3	Civil Engineering	12																					
4	Mechanical Engineering	16																					
5	Electrical Engineering	18																					

GOVERNMENT POLYTECHNIC, KOLHAPUR – 416004.
(An Autonomous Institute of Govt. Of Maharashtra)

SUMMER- 2024

EXAM SEAT NO.

--	--	--	--	--	--

LEVEL :- First

PROGRAM : COMMON

COURSE CODE :- CCH105

COURSE NAME :- Basic Mathematics

MAX. MARKS : 70

TIME : 03 Hrs

DATE :-25/5/2024

Instruction :-

- 1) Answers of two sections must be written in separate section answer book provided.
- 2) Illustrate your answers with sketches wherever necessary.
- 3) Use of non-programmable pocket calculator is permissible.
- 4) Mathematical and other tables shall be made available on request.
- 5) Assume and mention suitable additional data if necessary.
- 6) Use of Mobile is strictly prohibited.
- 7) QN- Question No., SQN-Sub Question No. R- Remembering, U- Understanding, A- Application.

QN	S QN	Question Text	R/ U/ A	Co	Mar ks												
Q.1		Attempt any THREE: (2 X 3)			06												
	a)	Find the value of x, if $\log_3(x + 6) = 2$	R	1													
	b)	If $A = \begin{bmatrix} 2 & 3 \\ 4 & 7 \end{bmatrix}$ $B = \begin{bmatrix} 1 & 3 \\ 4 & 6 \end{bmatrix}$ Find $3A-2B$	U	1													
	c)	Resolve into partial fraction $\frac{1}{x^2+3x+2}$	U	1													
	d)	Find equation of line passing through the points (-4,6) and (8,-3)	U	3													
	e)	Calculate range of the following data <table border="1" style="margin: 5px auto; border-collapse: collapse;"> <tr> <td style="padding: 2px;">x_i</td> <td style="padding: 2px;">10</td> <td style="padding: 2px;">20</td> <td style="padding: 2px;">30</td> <td style="padding: 2px;">40</td> <td style="padding: 2px;">50</td> </tr> <tr> <td style="padding: 2px;">f_i</td> <td style="padding: 2px;">7</td> <td style="padding: 2px;">5</td> <td style="padding: 2px;">3</td> <td style="padding: 2px;">2</td> <td style="padding: 2px;">1</td> </tr> </table>	x_i	10	20	30	40	50	f_i	7	5	3	2	1	R	2	
x_i	10	20	30	40	50												
f_i	7	5	3	2	1												
Q.2		Attempt any FOUR: (4 X 4)			16												
	a)	Find x, y and z if $\left\{ \begin{bmatrix} 1 & 3 & 2 \\ 2 & 0 & 1 \\ 3 & 1 & 2 \end{bmatrix} + 2 \begin{bmatrix} 3 & 0 & 2 \\ 1 & 4 & 5 \\ 2 & 1 & 0 \end{bmatrix} \right\} \begin{bmatrix} 1 \\ 2 \\ 3 \end{bmatrix} = \begin{bmatrix} x \\ y \\ z \end{bmatrix}$	U	1													
	b)	Resolve into partial fraction $\frac{9}{(x-1)(x+2)^2}$	A	1													
	c)	Resolve into partial fraction $\frac{3x+2}{(x^2+1)(x+1)}$	U	1													
	d)	The two sets of observations are given below. <table border="1" style="margin: 5px auto; border-collapse: collapse;"> <tr> <td style="padding: 2px;">Set I</td> <td style="padding: 2px;">Set II</td> </tr> <tr> <td style="padding: 2px;">Mean = 82.5</td> <td style="padding: 2px;">Mean = 48.75</td> </tr> <tr> <td style="padding: 2px;">S.D = 7.3</td> <td style="padding: 2px;">S.D = 8.35</td> </tr> </table> Which of two sets is more consistent?	Set I	Set II	Mean = 82.5	Mean = 48.75	S.D = 7.3	S.D = 8.35	A	2							
Set I	Set II																
Mean = 82.5	Mean = 48.75																
S.D = 7.3	S.D = 8.35																
	e)	Find equation of line parallel to $3x-2y+5 = 0$ and passing through the point(5,-6)	A	3													
	f)	find the mean deviation from mean of the following data <table border="1" style="margin: 5px auto; border-collapse: collapse;"> <tr> <td style="padding: 2px;">Marks</td> <td style="padding: 2px;">0-10</td> <td style="padding: 2px;">10-20</td> <td style="padding: 2px;">20-30</td> <td style="padding: 2px;">30-40</td> <td style="padding: 2px;">40-50</td> </tr> <tr> <td style="padding: 2px;">No.of students</td> <td style="padding: 2px;">05</td> <td style="padding: 2px;">08</td> <td style="padding: 2px;">15</td> <td style="padding: 2px;">16</td> <td style="padding: 2px;">6</td> </tr> </table>	Marks	0-10	10-20	20-30	30-40	40-50	No.of students	05	08	15	16	6	A	2	
Marks	0-10	10-20	20-30	30-40	40-50												
No.of students	05	08	15	16	6												
Q3		Attempt any TWO: (6 X 2)			12												
	a)	Calculate standard deviation and coefficient of variance of the following distribution <table border="1" style="margin: 5px auto; border-collapse: collapse;"> <tr> <td style="padding: 2px;">Marks</td> <td style="padding: 2px;">5</td> <td style="padding: 2px;">10</td> <td style="padding: 2px;">15</td> <td style="padding: 2px;">20</td> <td style="padding: 2px;">25</td> </tr> <tr> <td style="padding: 2px;">No.of students</td> <td style="padding: 2px;">6</td> <td style="padding: 2px;">16</td> <td style="padding: 2px;">28</td> <td style="padding: 2px;">38</td> <td style="padding: 2px;">46</td> </tr> </table>	Marks	5	10	15	20	25	No.of students	6	16	28	38	46	A	2	
Marks	5	10	15	20	25												
No.of students	6	16	28	38	46												
	b)	i) Find the length of perpendicular from the point (5,6) on the line $2x+y+6 = 0$ ii) Find the acute angle between the lines $3x-y=4$, $2x+y=3$	A U	3 3													
	c)	Solve the equation using matrix inversion method , $X+3y+2z = 6$, $3x-2y+5z= 5$, $2x-3y+6z = 7$	A	1													

GOVERNMENT POLYTECHNIC, KOLHAPUR – 416004.

(An Autonomous Institute of Govt. Of Maharashtra)

SUMMER-2024

EXAM SEAT NO.

LEVEL : First

PROGRAM : COMMON

COURSE CODE :- CCH105

COURSE NAME: BASIC MATHEMATICS

MAX. MARKS : **70**

TIME : 03 Hrs

DATE :- **25/5/2024**

QN	S Q N	Question Text	R/ U/ A	Co	Ma rks
Q.4		Attempt any FOUR: (2 X 4)			08
	a)	$2\cos 60^\circ \cdot \cos 10^\circ = \cos A + \cos B$. Find A & B.	R	4	
	b)	If $f(x) = x^3 + x^2 - 2$, find $f(1) + f(2)$	R	5	
	c)	State whether the function $f(x) = \frac{e^x + e^{-x}}{2}$ is even or odd	R	5	
	d)	Find $\frac{dy}{dx}$ if $y = x^e + e^x + e^e + a^x$	U	5	
	e)	Find $\frac{dy}{dx}$ if $y = e^{2x} \cdot (x^3 + 4)$	U	5	
	f)	Find the slope of the tangent to the curve $xy = 6$ at (1,6)	A	5	
Q.5		Attempt any FOUR: (4 X 4)			16
	a)	Without using calculator find the value of $\sin 150^\circ + \cos 300^\circ - \tan 315^\circ + \sec^2 360^\circ$	U	4	
	b)	Prove that, $\frac{\sin 8x - \sin 5x}{\cos 7x + \cos 6x} = \sin x + \cos x \cdot \tan \frac{x}{2}$	U	4	
	c)	Show that $\tan^{-1}\left(\frac{1}{2}\right) + \tan^{-1}\left(\frac{1}{3}\right) = \frac{\pi}{4}$	U	4	
	d)	Find $\frac{dy}{dx}$ if $x^3 + y^3 = 3axy$	U	5	
	e)	If $x = a(\cos t + t \sin t)$ and $y = a(\sin t - t \cos t)$ find $\frac{dy}{dx}$ at $t = \frac{\pi}{4}$	A	5	
	f)	Find the radius of curvature at (3,-4) to the curve $x^2 + y^2 = 25$.	U	5	
Q.6		Attempt any TWO: (6 X 2)			12
	a)	i) If $\tan A = \frac{1}{2}, \tan B = \frac{1}{3}$ find $\tan(A + B)$ ii) If $\sin A = 0.4$ find $\cos 2A$ using multiple angle formula	R	4	
	b)	Find $\frac{dy}{dx}$ if $y = x^{\sin x} + \tan x^x$	U	5	
	c)	i) Find $\frac{dy}{dx}$ if $y = \frac{1+\sqrt{x}}{1-\sqrt{x}}$ ii) Find equation of tangent to the curve $y = x(2-x)$ at the point (2,0)	A	5	

GOVERNMENT POLYTECHNIC, KOLHAPUR – 416004.

(An Autonomous Institute of Govt. Of Maharashtra)

EVEN TERM END EXAM SUMMER -2024

EXAM SEAT NO.

LEVEL :- **FIRST** PROGRAM : **COMMON**

COURSE CODE :- **CCG105/CCF105/X104**

COURSE NAME **BASIC MATHEMATICS**

MAX. MARKS : **80** TIME : **03Hrs.** DATE :- **24/05/2024**

Instruction :-

- 1) Answers must be written in the main answer book provided.(and supplements if required)
- 2) Illustrate your answers with sketches wherever necessary.
- 3) Use of non-programmable pocket calculator is permissible.
- 4) Mathematical and other tables shall be made available on request.
- 5) Assume and mention suitable additional data if necessary.
- 6) Use of Mobile is strictly prohibited.
- 7) QN- Question No., SQN-Sub Question No. R- Remembering, U- Understanding, A- Application.

QN	S Q N	Question Text	R/ U/ A	Co CCG 105	Mar ks
Q.1		Attempt any FOUR :			08
	a)	If $2^5 = 32$ express it in equivalent Logarithmic form.	U	1	
	b)	Find x if $\begin{vmatrix} 0 & 7 & -2 \\ 11 & x & 10 \\ 4 & 8 & 1 \end{vmatrix} = 0$	R	2	
	c)	Resolve into partial fractions $\frac{1}{(x-3)(x+2)}$	U	3	
	d)	Find A, if $2A+3 \begin{bmatrix} 1 & 3 \\ 2 & 5 \end{bmatrix} = \begin{bmatrix} 5 & 7 \\ 6 & 3 \end{bmatrix}$	R	4	
	e)	If $A = \begin{bmatrix} 2 & 3 \\ 4 & 5 \end{bmatrix}, B = \begin{bmatrix} 3 & 7 \\ 1 & 9 \end{bmatrix}$ then find $3A-2B$.	R	4	
	f)	If $A = \begin{bmatrix} 3 & 9 \\ -1 & -3 \end{bmatrix}$ show that A^2 is null Matrix.	A	4	
Q.2		Attempt any FOUR :			16
	a)	Find the value of x if $\log_2(x^2 - 6x + 40) = 5$.	A	1	
	b)	Using Cramer's Rule solve $x - y - 2z = 1, 2x + 3y + 4z = 4, 3x - 2y - 6z = 5$	A	2	
	c)	Resolve into partial fractions $\frac{4x+1}{x^2+3x+2}$	A	3	
	d)	Find x, y, z , if $\left\{ \begin{bmatrix} 1 & 3 & 2 \\ 2 & 0 & 1 \\ 3 & 1 & 2 \end{bmatrix} + 2 \begin{bmatrix} 3 & 0 & 2 \\ 1 & 4 & 5 \\ 2 & 1 & 0 \end{bmatrix} \right\} \begin{bmatrix} 1 \\ 2 \\ 3 \end{bmatrix} = \begin{bmatrix} x \\ y \\ z \end{bmatrix}$	A	4	
	e)	Resolve into partial fractions $\frac{x^2+1}{(x+1)(x^2+4)}$	A	3	
	f)	If $A = \begin{bmatrix} 1 & 0 & 0 \\ 3 & 3 & 0 \\ 5 & 2 & -1 \end{bmatrix}$ Find inverse of matrix by using adjoint method.	A	4	

P.T.O

Q.3	Attempt any FOUR :			16
a)	Prove that, $\frac{1}{\log_2 8} + \frac{1}{\log_4 8} + \frac{1}{\log_{64} 8} = 3$	A	1	
b)	Solve the following equation $\begin{vmatrix} x+10 & x+2 & x+3 \\ x+4 & x+5 & x+6 \\ 2x+7 & x+8 & 0 \end{vmatrix} = 0$	A	2	
c)	Resolve into partial fractions $\frac{x^2 + 6x - 8}{x^3 - 4x}$	A	3	
d)	If $A = \begin{bmatrix} 1 & 2 \\ -2 & 3 \end{bmatrix}$, $B = \begin{bmatrix} 2 & 1 \\ 2 & 3 \end{bmatrix}$, & $C = \begin{bmatrix} -3 & 1 \\ 2 & 0 \end{bmatrix}$ then verify that $A(B+C) = AB+AC$.	A	4	
e)	Resolve into partial fractions $\frac{3x+2}{(x-2)(x+1)^2}$	A	3	
f)	Find x & y , if $\begin{bmatrix} 2x+y & -1 & 1 \\ 3 & 4y & 4 \end{bmatrix} + \begin{bmatrix} -1 & 6 & 4 \\ 3 & 0 & 3 \end{bmatrix} = \begin{bmatrix} 3 & 5 & 5 \\ 6 & 18 & 7 \end{bmatrix}$	A	4	

GOVERNMENT POLYTECHNIC, KOLHAPUR -416004
(An Autonomous Institute of Govt. of Maharashtra)
SUMMER-2024

EXAM SEAT NO-

--	--	--	--	--	--

LEVEL- FIRST
COURSE CODE- CCH201

PROGRAM-COMMON

COURSE NAME- COMMUNICATION SKILLS

MAX MARKS- 70

TIME- 03 Hrs.

DATE- 24/5/2024

QN.	S Q N	Question Text	R/ U/ A	CO CCH10 6	Mark																		
Q.4		Attempt any FOUR: (2X4)			08																		
	a)	List down at least four advantages of written communication	R	4																			
	b)	Define the term 'Proxemics' with one example.	R	5																			
	c)	State the demerits of using OHP for presentation.	R	6																			
	d)	State the meaning of the term- 'Vocalics'.	R	5																			
	e)	Enlist the various advantages of using graphical communication for formal situation.	R	4																			
	f)	Explain the meaning of term-'Posture'.	R	5																			
Q.5		Attempt any FOUR: (4X4)			16																		
	a)	Explain the importance of proper eye contact.	U	5																			
	b)	Illustrate with one example the importance of grooming for engineering student.	U	5																			
	c)	Explain the usefulness of Dairy-writing for a professional person.	U	4																			
	d)	Provide the possible Precautions to be taken for Power Point Presentation.	U	6																			
	e)	Explain the given statement here 'Reading makes a full man, Conference a ready man and writing an exact man.'	U	4																			
	f)	Illustrate the positive Posture at work place.	U	5																			
Q.6		Attempt any TWO:(6X2)			12																		
	a)	Your department wants to buy electric equipment for use. Design a suitable letter of enquiry from your department requesting the local dealer to send you price list, catalogue in a week. While designing the letter consider yourself as Manager of the Department and send this document to M/S. Bharat Heavy Electrical Supplier, Rajarampuri, 4th Lane, Kolhapur.	A	5																			
	b)	In an automobile factory of your M.I.D.C., You have been working as a Unit in-charge of manufacturing section. This month there is a shortage of production. So draft a fall in Production report of this and address the report to –The General Manager, Administration Department.	A	5																			
	c)	A state level presentation competition was held to celebrate the 'Engineer's day' in your polytechnic. The course wise response of the students was given here. Using the given data, prepare a bar graph to represent this information.	A	4																			
		<table border="1" style="width: 100%; border-collapse: collapse;"> <thead> <tr> <th style="width: 10%;">Sr. No.</th> <th style="width: 50%;">Course Name</th> <th style="width: 40%;">No. of student participated</th> </tr> </thead> <tbody> <tr> <td>1</td> <td>Electronics Engineering</td> <td>16</td> </tr> <tr> <td>2</td> <td>Computer Engineering</td> <td>14</td> </tr> <tr> <td>3</td> <td>Civil Engineering</td> <td>12</td> </tr> <tr> <td>4</td> <td>Mechanical Engineering</td> <td>16</td> </tr> <tr> <td>5</td> <td>Electrical Engineering</td> <td>18</td> </tr> </tbody> </table>	Sr. No.	Course Name	No. of student participated	1	Electronics Engineering	16	2	Computer Engineering	14	3	Civil Engineering	12	4	Mechanical Engineering	16	5	Electrical Engineering	18			
Sr. No.	Course Name	No. of student participated																					
1	Electronics Engineering	16																					
2	Computer Engineering	14																					
3	Civil Engineering	12																					
4	Mechanical Engineering	16																					
5	Electrical Engineering	18																					

GOVERNMENT POLYTECHNIC, KOLHAPUR – 416004.

(An Autonomous Institute of Govt. Of Maharashtra)

SUMMER- 2024

EXAM SEAT NO.

--	--	--	--	--	--

LEVEL: - First

PROGRAM: Common

COURSE CODE: - CCH201

COURSE NAME: - Communication Skills

MAX. MARKS: 70

TIME: 03 Hrs

DATE: - 24/5/2024

Instruction: -

- 1) Answers of two sections must be written in separate section answer book provided.
- 2) Illustrate your answers with sketches wherever necessary.
- 3) Use of non-programmable pocket calculator is permissible.
- 4) Mathematical and other tables shall be made available on request.
- 5) Assume and mention suitable additional data if necessary.
- 6) Use of Mobile is strictly prohibited.
- 7) QN- Question No., SQN-Sub Question No. R- Remembering, U- Understanding, A- Application.

QN	S Q N	Question Text	R/ U/ A	Co CCH10 6	Ma rks
Q.1		Attempt any THREE: (2 X 3)			06
	a)	Write any two examples of homophones. (Pairs.)	R	1	
	b)	Write meaningful words with the help of following suffixes: (-ness, -ment, -ly, -y.)	U	1	
	c)	Define Downward Communication.	R	2	
	d)	Why group discussion is conducted in an interview?	U	3	
	e)	Disadvantages of Oral Communication	R	3	
Q.2		Attempt any FOUR: (4 X 4)			16
	a)	Write a note on Collocation.	R	1	
	b)	“Communication is a two-way process “Elucidate it with the help of examples.	U	2	
	c)	Discuss basic principles of effective communication.	A	2	
	d)	Characteristics of Oral Communication.	R	2	
	e)	Write a note on the significance and role of communication in society.	U	2	
	f)	Explain in detail various barriers to communication.	R	3	
Q.3		Attempt any TWO: (6 X 2)			12
	a)	Explain the advantages and disadvantages of written communication.	R	2	
	b)	What do you understand by non-verbal communication?	R	2	
	c)	Essential Ways to Overcome Communication Barriers. Explain.	U	3	

P.T.O.

GOVERNMENT POLYTECHNIC, KOLHAPUR – 416004.

(An Autonomous Institute of Govt. Of Maharashtra)

EVEN TERM END EXAM SUMMER -2024**EXAM SEAT NO.**

--	--	--	--	--	--

LEVEL : - **FIRST**PROGRAM : **COMMON**COURSE CODE :- **CCG203**COURSE NAME **Communication skill in English**MAX. MARKS : **40** TIME : **02Hrs.**DATE :- **24/05/2024**

Instruction :-

- 1) Answers must be written in the main answer book provided.(and supplements if required)
- 2) Illustrate your answers with sketches wherever necessary.
- 3) Use of non-programmable pocket calculator is permissible.
- 4) Mathematical and other tables shall be made available on request.
- 5) Assume and mention suitable additional data if necessary.
- 6) Use of Mobile is strictly prohibited.
- 7) QN- Question No., SQN-Sub Question No. R- Remembering, U- Understanding, A- Application.

QN	S Q N	Question Text	R/ U/ A	Co CCG 203	Mar ks
Q.1		Attempt any FOUR :(Answer the following questions in 3-5 sentences)			08
	a)	Explain in brief 'positive feedback' in your own words.	U	1	
	b)	Describe any two disadvantages of Oral communication.	R	2	
	c)	Enlist four examples in which Written communication is used.	U	3	
	d)	Write at least one strength and one precaution of Media-Aided presentation.	R	5	
	e)	Describe 'Mock Interview' in short.	U	6	
	f)	Write at least two expected questions which can be asked in a job interviews.	U	6	
Q.2		Attempt any FOUR (answer the following questions in 12-14 sentences)			16
	a)	Explain with suitable example with neat labelled diagram:- i) Horizontal communication ii) Diagonal communication	U	1	
	b)	Give a situation of your own where the communication cycle is complete. Identify the elements of communication in the situation.	A	1	
	c)	Describe in detail at least four characteristics of Oral communication in your own words.	R	2	
	d)	Explain merits and demerits of Written communication.	U	3	
	e)	State any four precautions that one should take while making a presentation.	R	5	
	f)	Explain the importance of dress and appearance, soft make-up, descent jewellery of a candidate who is going to face an interview for a job.	A	6	
Q.3		Attempt any TWO (Do as directed in the question)			16
	a)	Draw a neat labelled diagram of communication cycle with its elements. Explain in detail with suitable example each element involved in the communication process.	U	1	
	b)	Write an application with your resume to the Managing Director, Swan Industries, Mumbai for the post of an Executive Engineer.	A	3	

P.T.O.

c) Draw a bar graph with the help of following data. Indicate the components, figures and the period of time in the graph. Use pencil shading, formal color scheme, design etc. to make the graph attractive -----

Incidents of Railway Accidents in India

Year →	2020	2021	2022
Causes ↓			
Failure of Signal	20	15	10
Administration Lapse	15	20	10
Negligence	30	20	30
Unknown	10	10	40
Total	75	65	90

A

4

GOVERNMENT POLYTECHNIC, KOLHAPUR – 416004.

(An Autonomous Institute of Govt. Of Maharashtra)

EVEN TERM END EXAM SUMMER -2024**EXAM SEAT NO.**

--	--	--	--	--	--

LEVEL :- **FIRST**PROGRAM : **CIVIL/MECHANICAL/METALLURGICAL ENGG.**COURSE CODE :- **CCG101/CCF101**COURSE NAME **ENGINEERING PHYSICS**MAX. MARKS : **80** TIME : **03Hrs.**DATE :- **22/05/2024**

Instruction :-

- 1) Answers must be written in the main answer book provided.(and supplements if required)
- 2) Illustrate your answers with sketches wherever necessary.
- 3) Use of non-programmable pocket calculator is permissible.
- 4) Mathematical and other tables shall be made available on request.
- 5) Assume and mention suitable additional data if necessary.
- 6) Use of Mobile is strictly prohibited.
- 7) QN- Question No., SQN-Sub Question No. R- Remembering, U- Understanding, A- Application.

QN	S Q N	Question Text	R/ U/ A	Co EEG 101	Mar ks
Q.1		Attempt any FOUR :			08
	a)	Define i) elastic limit ii) Strain.	R	2	
	b)	Define fundamental quantity and derived quantity.	R	1	
	c)	State any two applications of viscosity.	A	2	
	d)	State any two characteristics of linear S.H.M.	U	3	
	e)	Explain Stoke's Law of viscosity.	U	2	
	f)	Define i) Periodic motion ii) SHM.	R	3	
Q.2		Attempt any FOUR :			16
	a)	Explain the Young's modulus, Bulk modulus and modulus of rigidity. Give the relation between them.	U	2	
	b)	Derive an expression for coefficients of viscosity using Stoke's method.	A	2	
	c)	Define i) Amplitude of SHM ii) Period of SHM iii) Frequency of SHM iv) Phase of SHM.	R	3	
	d)	Write the significant figures for the following : i) 0.043 ii) 4.03×10^8 iii) 0.0730 iv) 3.720.	A	1	
	e)	Explain the system of units – CGS, MKS.	U	1	
	f)	Define free and forced oscillations. Give one example of each.	R	3	
Q.3		Attempt any FOUR :			16
	a)	Define i) Viscosity ii) terminal Velocity iii) Velocity Gradient iv) Coefficient of Viscosity.	R	2	
	b)	A weight exerts force of 100 N on a steel wire of diameter 0.4mm. Find the extension produced in the wire, if original length of wire is 5m. (Given $Y = 2 \times 10^{12} \text{ N/m}^2$)	A	2	
	c)	Mention any four characteristics of transverse wave.	U	3	
	d)	Explain random error, instrumental error with one example of each.	U	1	
	e)	Find the change in volume of 2 litre of liquid due to change in pressure of 10^7 N/m^2 if bulk modulus of liquid is $1.67 \times 10^{11} \text{ N/m}^2$.	A	2	
	f)	Explain the phenomenon of Resonance and any two applications of resonance.	U	3	

P.T.O

QN	S Q N	Question Text	R/ U/ A	Co CCG 101	M ar ks
Q.4		Attempt any FOUR :			08
	a)	State and explain Ohm's Law.	U	4	
	b)	Write full form of LASER.	R	5	
	c)	Define i) Nano meter ii) Nano particle.	R	5	
	d)	State the principle of production of X-rays.	R	5	
	e)	Define i) Echo ii) Reverberation.	R	6	
	f)	State any two applications of ultrasonic waves.	R	6	
Q.5		Attempt any FOUR :			16
	a)	Derive formula for effective resistance of a series combination of resistances.	A	4	
	b)	Explain the refraction of light through a glass prism using ray diagram.	U	4	
	c)	State and explain properties of laser.	U	5	
	d)	State applications of nanotechnology in the field of electronics and textile (two each)	A	5	
	e)	For an equilateral prism the angle of minimum deviation is 30° . Find the refractive index of the prism.	A	4	
	f)	Calculate the specific resistance of wire 6m in length, 0.4mm in diameter and having a resistance of 30Ω .	A	4	
Q.6		Attempt any FOUR :			16
	a)	Derive the prism formula.	A	4	
	b)	Explain population inversion with the help of neat diagram.	U	5	
	c)	With the help of neat diagram, explain the construction of X-ray Coolidge tube.	R	5	
	d)	Explain any one method of production of ultrasonic waves.	U	6	
	e)	When a resistance of 15Ω is connected in the right gap of a meter bridge, the null point is obtained at 40cm from the left end. Find The resistance in the left gap.	A	5	
	f)	The volume of a hall is 8000m^3 and reverberation time is 2 sec. If the absorbing surface of the hall is 6400m^2 . Determine the coefficient of absorption.	A	6	

GOVERNMENT POLYTECHNIC, KOLHAPUR – 416004.

(An Autonomous Institute of Govt. Of Maharashtra)

EVEN TERM END EXAM SUMMER -2024**EXAM SEAT NO.**

--	--	--	--	--	--

LEVEL :- **FIRST**PROGRAM : **EE / IE / IT / E& TC**COURSE CODE :- **CCG102 / CCF102**COURSE NAME **ENGINEERING PHYSICS**MAX. MARKS : **80** TIME : **03Hrs.**DATE :- **22/05/2024**

Instruction :-

- 1) Answers must be written in the main answer book provided.(and supplements if required)
- 2) Illustrate your answers with sketches wherever necessary.
- 3) Use of non-programmable pocket calculator is permissible.
- 4) Mathematical and other tables shall be made available on request.
- 5) Assume and mention suitable additional data if necessary.
- 6) Use of Mobile is strictly prohibited.
- 7) QN- Question No., SQN-Sub Question No. R- Remembering, U- Understanding, A- Application.

QN	S Q N	Question Text	R/ U/ A	Co CCG 102	Mar ks
Q.1		Attempt any FOUR :			08
	a)	State any two fundamental physical quantities and write their SI units.	R	1	
	b)	Classify following into fundamental and derived SI units: kg, A, N, m/s.	U	1	
	c)	Write any two points regarding significance of factor of safety.	A	2	
	d)	Define velocity gradient and write its unit.	R	2	
	e)	State any two applications of viscosity.	A	2	
	f)	State any two characteristics of SHM.	R	3	
Q.2		Attempt any FOUR :			16
	a)	The length of a wire is expressed in four ways as 0.00350km, 3.50m, 350cm and 3500mm. Find the number of significant figures in each case.	A	1	
	b)	Define i) Deforming force ii) Restoring force iii) Stress iv) strain.	R	2	
	c)	A wire of length 3m and cross-sectional area $0.78 \times 10^{-4} \text{m}^2$ extends by 0.003m. When loaded with a mass of 150kg. Calculate Young's modulus. (Take : $g = 9.8 \text{m/s}^2$)	A	2	
	d)	State and explain Newton's Law of viscosity. Hence define coefficient of viscosity.	U	2	
	e)	State any four characteristics of transverse wave.	U	3	
	f)	Give reasons for following : i) Soldiers are asked to break their steps while crossing a bridge. ii) Radio receiver is tuned to a particular frequency.	U	3	
Q.3		Attempt any FOUR :			16
	a)	State any four requirements of good unit.	U	1	
	b)	The mass of an object is measured as 37.6gm by a weighing machine of least count 0.02gm. Estimate percentage error in measurement.	A	1	
	c)	Classify following into elastic body and plastic body: Clay, Rubber, Steel, Mud, Wax, Glass, Copper and Aluminium.	U	2	
	d)	Obtain formula for coefficient of viscosity by Stoke's method.	A	2	

P.T.O.

	e)	Define : i) Periodic motion ii) SHM iii) Period iv) Frequency	R	3	
	f)	Distinguish between free and forced vibrations (any four points)	U	3	
Q.4		Attempt any FOUR:			08
	a)	Give any two advantages of optical fiber.	U	6	
	b)	Define specific resistance. Give its unit.	R	4	
	c)	State any two properties of X-rays.	R	5	
	d)	Define nanoscale and nanoparticle.	R	5	
	e)	State Ohms law. Give unit of resistance.	R	4	
	f)	State the principle of optical fiber.	R	6	
Q.5		Attempt any FOUR:			16
	a)	State and explain properties of laser.	U	5	
	b)	State and prove series law of resistances.	A	4	
	c)	Give any four applications of optical fiber.	U	6	
	d)	Derive Prism Formula for refractive index.	A	4	
	e)	Give any four applications of nanotechnology.	U	5	
	f)	Find the effective resistance if four resistances of 2Ω each are connected in parallel.	A	4	
Q.6		Attempt any FOUR:			16
	a)	Describe how X-ray are produced by using Coolidge tube.	A	5	
	b)	Define refraction of light. State Snell's law of refraction.	R	4	
	c)	Explain stimulated emission of laser, with neat diagrams.	U	5	
	d)	Derive the balancing condition of Wheatstone's network.	A	4	
	e)	Explain structure of optical fiber with the help of neat labelled diagram.	U	6	
	f)	The equilateral glass prism under minimum deviation condition has an angle of incidence 40° . Find its refractive index.	A	4	

GOVERNMENT POLYTECHNIC, KOLHAPUR – 416004.

(An Autonomous Institute of Govt. Of Maharashtra)

SUMMER 2024**EXAM SEAT NO.**

--	--	--	--	--	--

LEVEL: - First

PROGRAM: (ME/CE/MT)

COURSE CODE: - CCH106

COURSE NAME: - ENGINEERING GRAPHICS

MAX. MARKS: 70

TIME: 04 Hrs

DATE: - 22/5/2024

Instruction :-

- 1) Answers of two sections must be written in separate section answer book provided.
- 2) Illustrate your answers with sketches wherever necessary.
- 3) Use of non-programmable pocket calculator is permissible.
- 4) Mathematical and other tables shall be made available on request.
- 5) Assume and mention suitable additional data if necessary.
- 6) Use of Mobile is strictly prohibited.
- 7) QN- Question No., SQN-Sub Question No. R- Remembering, U- Understanding, A- Application.

QN	S Q N	Question Text	R/ U/ A	Co CCH 107-	Ma rks
Q.1		Attempt any THREE: (3 X 2M)			06
	a)	Draw conventions of the following lines i) Hidden line ii) Long break line	R	1	
	b)	Calculate Length of Scale if RF is 1:40 and maximum length to be measured is 5 meters.	A	1	
	c)	Draw aligned and unidirectional dimensioning system	A	1	
	d)	Draw pentagon of side 30mm by geometric construction method.	A	1	
Q.2		Attempt any THREE: (3 X 6 M)			18
	a)	Draw an ellipse having major and minor axes 120 mm and 70 mm respectively by concentric circles method	U	2	
	b)	A fixed-point F is 80 mm from a fixed straight line AB. Draw parabola by directrix focus method.	U	2	
	c)	A point P is 55 mm and 35 mm away from two fixed straight lines, which are at right angles to each other. Draw the rectangular hyperbola through point P within 15 mm distance from each line.	A	2	
	d)	Draw helix on a cylinder of 50 mm diameter of one turn, given pitch equal to 40 mm.	A	2	
Q.3		Attempt any TWO: (2 X 5M)			10
	a)	A line AB of length 65 mm has its end A 20 mm from both the reference planes. Line is parallel to V.P. and inclined at 35° to the H.P. Draw three views of the line and find its plan length.	U	3	
	b)	End A and B of a line AB is 15 mm and 55 mm respectively in front of the V.P. Elevation length of the line is 60 mm and it is parallel to the XY line and 15 mm above it. Draw three views of the line and find its true length and inclination with V.P.	U	3	
	c)	A straight line AB of length 70 mm has its end A on the HP and 30 mm in front of the V.P. Line is parallel to V.P. and inclined at 45° to the H.P. Draw three views of the line AB and find distance of end B from H.P. and length of the plan.	U	3	

P.T.O.

GOVERNMENT POLYTECHNIC, KOLHAPUR – 416004.

(An Autonomous Institute of Govt. Of Maharashtra)

SUMMER 2024**EXAM SEAT NO.**

--	--	--	--	--	--

LEVEL :- First

PROGRAM : ME/CE/MT

COURSE CODE :- CCH106

COURSE NAME:-ENGINEERING GRAPHICS

MAX. MARKS : 70

TIME : 04 Hrs.

DATE :- 22/5/2024

QN	S Q N	Question Text	R/ U/ A	Co	Ma rks
Q.4		Attempt any TWO: (5M X 2)			10
	a)	A thin hexagonal plate , 25mm side is resting on a corner in the H.P. with its surface perpendicular to H.P. and inclined at 45° to V.P. Draw its projections when two sides are perpendicular to V.P.	U	107-4	5
	b)	A Circular plate of negligible thickness of 50mm diameter has a point on its circumference in V.P. its surface is perpendicular to H.P. and inclined to V.P. such that front view appears as an ellipse with minor axis 35mm. Draw its projections and find the inclination of the plate with V.P.	U	107-4	5
	c)	A thin pentagonal plate ABCDE, 25mm side, has a side AB parallel to V.P. and 15mm away from it. Draw its views, when its surface is perpendicular to H.P. and inclined at 30° to V.P.	U	107-4	5
Q.5		Attempt any ONE: (14 M X 01)			14
	a)	Figure No-01 Shows the pictorial view of an object. Using first angle method Draw 1) Front View looking in the direction-X 2) Side View from Left	U	107-5	7 7
	b)	Figure No-02 Shows the pictorial view of an object. Using first angle method Draw 1) Front View looking in the direction-X 2) Top View	U	107-5	7 7
Q.6		Attempt any ONE: (12M X 01)			12
	a)	Figure No-03 Shows the pictorial view of an object. Using first angle method Draw 1) Sectional Front View looking in the direction-X along sect-A-A 2) Top View	U	107-5	6 6
	b)	Figure No-04 Shows the pictorial view of an object. Using first angle method Draw 1) Sectional Front View looking in the direction-X along sect-A-A 2) Top View	U	107-5	6 6

P.T.O.

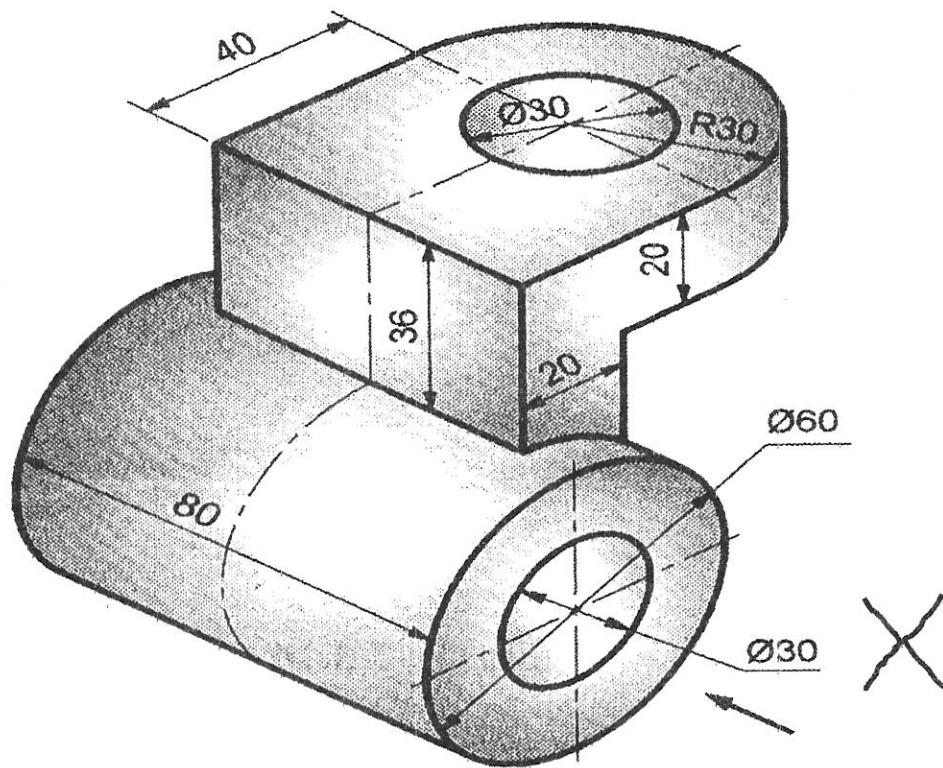

FIGURE NO-01

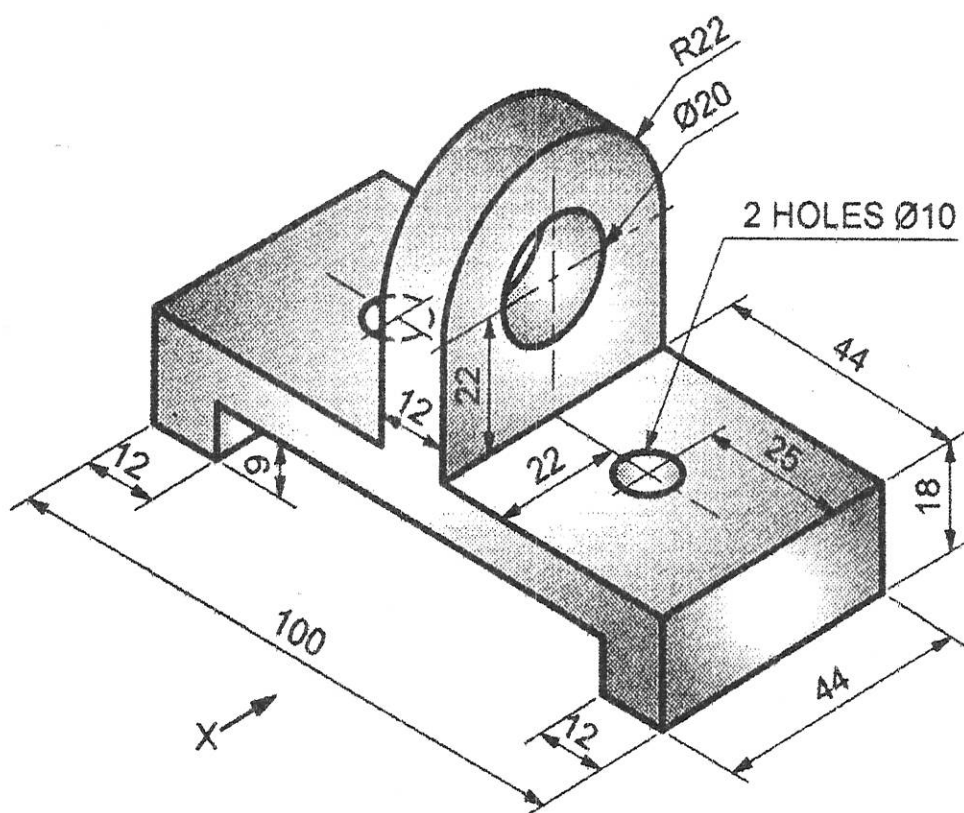

FIGURE NO-02

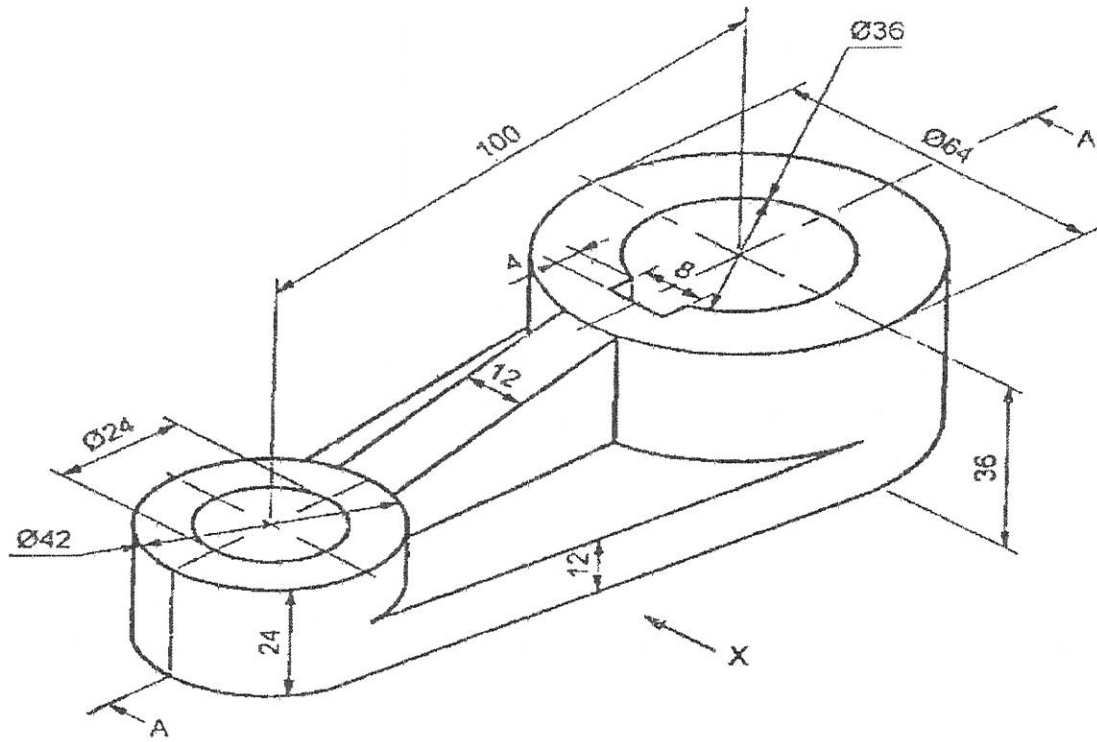

FIGURE NO-03

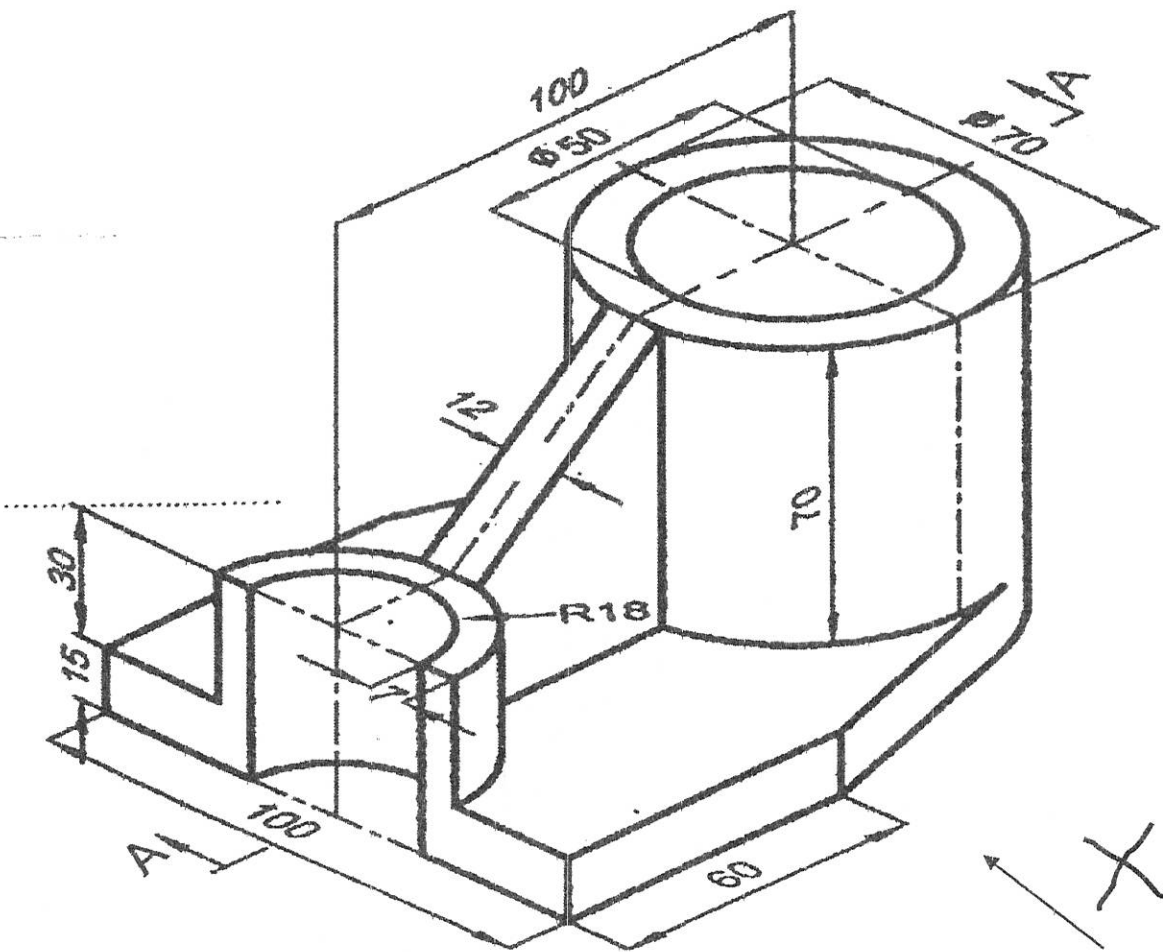

FIGURE NO-04

*** **

GOVERNMENT POLYTECHNIC, KOLHAPUR – 416004.

(An Autonomous Institute of Govt. Of Maharashtra)

EVEN TERM END EXAM SUMMER -2024**EXAM SEAT NO.**

--	--	--	--	--	--	--

LEVEL : - **FIRST** PROGRAM : **CE/ME/MT**COURSE CODE :- **CCG107/CCF107**COURSE NAME **ENGINEERING DRAWING - I**MAX. MARKS : **80** TIME : **04Hrs.** DATE :- **22/ 05 / 2024**

Instruction :-

- 1) Answers must be written in the main answer book provided.(and supplements if required)
- 2) Illustrate your answers with sketches wherever necessary.
- 3) Use of non-programmable pocket calculator is permissible.
- 4) Mathematical and other tables shall be made available on request.
- 5) Assume and mention suitable additional data if necessary.
- 6) Use of Mobile is strictly prohibited.
- 7) QN- Question No., SQN-Sub Question No. R- Remembering, U- Understanding, A- Application.

QN	S Q N	Question Text	R/ U/ A	Co CCG 107	Mar ks
Q.1		Attempt any TWO :			08
	a)	Construct a scale 1:50 to read upto 6 meters in meters and decimeters. Show on it a distance 4.9 meters.	R & U	1	4
	b)	Draw a neat sketch showing aligned system of dimensioning and unidirectional system of dimensioning.	R & U	1	4
	c)	Illustrate with neat sketch cutting plane line and hidden line.	R & U	1	4
Q.2	a)	Attempt any TWO :			12
	i)	Draw the involute of a pentagon having each side of length 20mm.	U & A	2	06
	ii)	A circle of 60mm diameter rolls outside and along another fixed circle of 160mm diameter. Draw an epicycloid for one complete revolution of the rolling circle.	U & A	2	06
	iii)	Distance between two fixed points F_1 and F_2 is 80mm. Point P moves in such a way that the difference between its distances from F_1 and F_2 is always constant and is equal to 50mm. Trace the curve by point 'P'.	A & A	2	06
	b)	Attempt any TWO :			08
	i)	Construct an ellipse when its major axis is 100mm and minor axis is 70mm by using concentric circle method.	U& A	2	04
	ii)	Draw a parabola having base length 80mm and axis height 50mm by the rectangle method.	U& A	2	04
	iii)	Draw a helix of one convolution when diameter of the cylinder is 60mm and pitch is 40mm.	U& A	2	04
Q.3		Attempt any TWO :			12
	a)	A line AB of length 75mm has its end 'A' 10mm above H.P. Line is parallel to V.P. and 20mm in front of it, plan length is 50mm. Draw the projections of lone AB.	R & U	3	06

P.T.O

Y4

	b) A line AB of length 70mm has its end 'A' 10mm in front of V.P. Line is parallel to H.P. and 30mm above it. Draw projections of line AB when elevation length is 55mm. Find inclination of line with V.P.	R & U	3	
	c) A straight line of true length 70mm has its end A on the H.P. and 20mm in front of V.P. Line is parallel to V.P. and inclined 40° to the H.P. Draw plan length of line.	R & U	3	

P.T.O. 2/4

GOVERNMENT POLYTECHNIC, KOLHAPUR – 416004.

(An Autonomous Institute of Govt. Of Maharashtra)

SUMMER- 2024

EXAM SEAT NO.

--	--	--	--	--	--

LEVEL :- *First*

PROGRAM : *CE|ME|MT*

COURSE CODE :- CCG107

COURSE NAME :- ENGINEERING DRAWING -I

MAX. MARKS : 80 TIME : 04 Hrs DATE :- *22/5/2024*

Instruction :-

- 1) Answers of two sections must be written in separate section answer book provided.
- 2) Illustrate your answers with sketches wherever necessary.
- 3) Use of non-programmable pocket calculator is permissible.
- 4) Mathematical and other tables shall be made available on request.
- 5) Assume and mention suitable additional data if necessary.
- 6) Use of Mobile is strictly prohibited.
- 7) QN- Question No., SQN-Sub Question No. R- Remembering, U- Understanding, A- Application.

QN	S Q N	Question Text	R/ U/ A	CO	Ma rks
Q.4		Attempt any TWO :			12
	a)	A pentagonal plate of 40 mm side is resting on one of its sides on HP such that plate is inclined at 40° with HP and perpendicular to VP. The center of plate is 50 mm from VP. Draw three views of pentagonal plate.	U	4	6
	b)	A rectangular plate having smallest side 40 mm and longest side 60 mm is kept on the HP on its smaller side with surface perpendicular to V.P. It is inclined to HP in such a way that top view appears as a square. Draw three views and find inclination of plane with HP.	U	4	6
	c)	A hexagonal plate of side 30 mm has a corner is VP and its surface making 40° to VP and perpendicular to HP. Draw its three views.	U	4	6
Q.5		Attempt any ONE :			14
	a)	Figure No-01 shows pictorial view of an object. Draw following views (i) Front view looking in the direction X (ii) Top view	U	5	8 6
	b)	Figure No-02 shows pictorial view of an object. Draw following views (i) Front view looking in the direction X (ii) Side view looking in the direction Y	U	5	8 6
Q.6		Attempt any ONE :			14
	a)	A pictorial view of an object is shown in Fig.No.3. Draw (using first angle method). (i) Sectional front view in x-direction (Along the cutting plane A-A) (ii) Top view	U	5	8 6
	b)	A pictorial view of an object is shown in Fig. No.4. Draw the following. (i) Sectional front view, along section P-Q (ii) Left Hand Side view.	U	5	8 6

P. T.O. 3/4

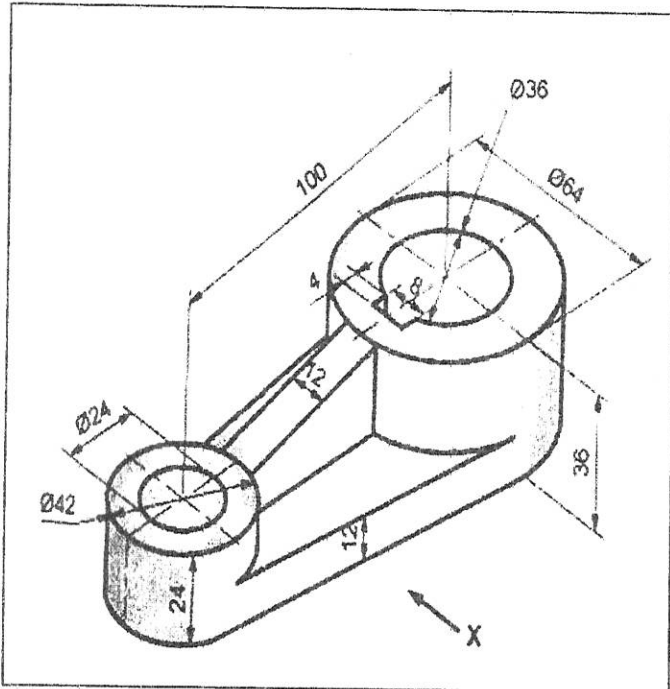

Q-5-A-FIG NO-01

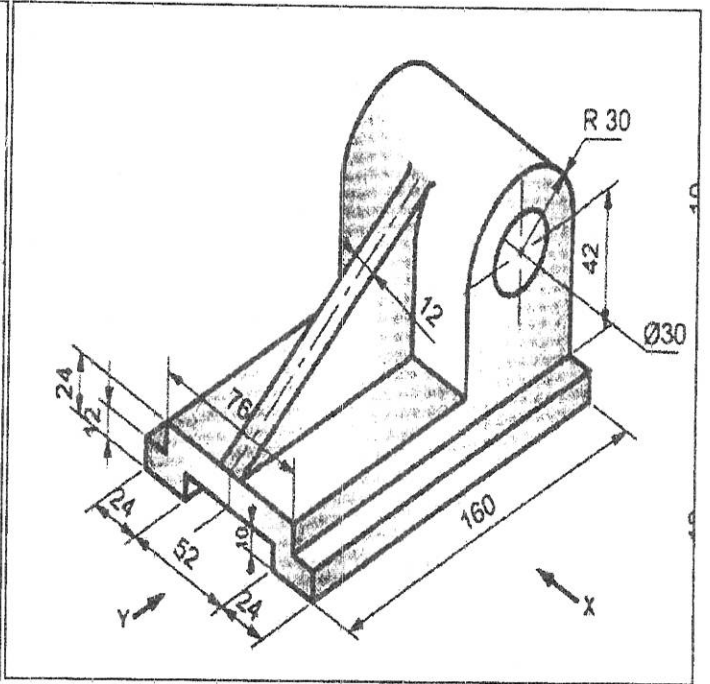

Q-5-B-FIG NO-02

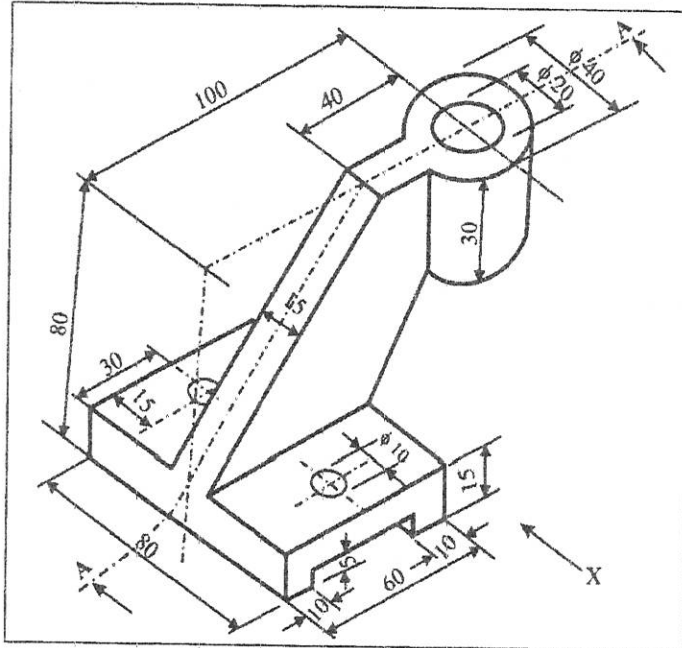

Q-6-A-FIG NO-03

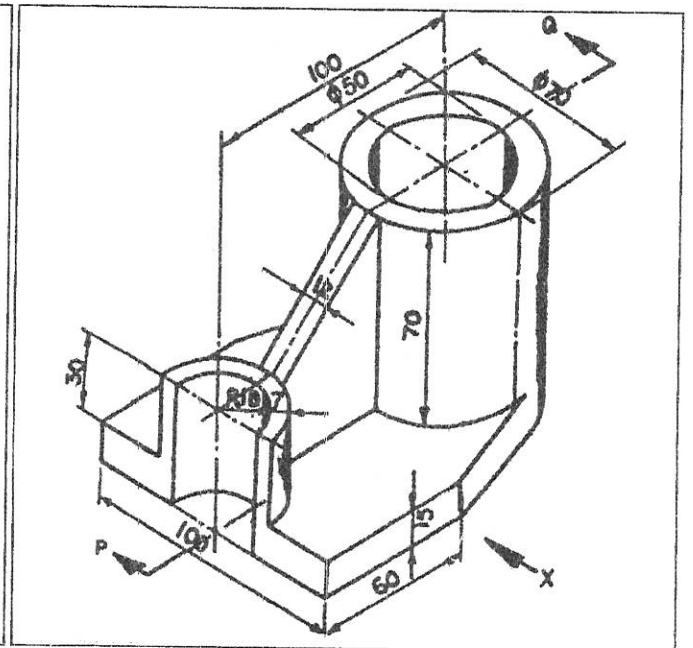

Q-6-B-FIG NO-04

C

GOVERNMENT POLYTECHNIC, KOLHAPUR – 416004.
(An Autonomous Institute of Govt. Of Maharashtra)
SUMMER-2024

EXAM SEAT NO.

--	--	--	--	--	--

LEVEL : -Third

COURSE CODE :- CCH301

MAX. MARKS : 70

TIME : 03 Hrs

PROGRAM : CE/ME/IT/EE/ET/MT

COURSE NAME :-APPLIED MATHEMATICS

DATE :- 21 / 5 / 2024

Instruction :-

- 1) Answers of two sections must be written in separate section answer book provided.
- 2) Illustrate your answers with sketches wherever necessary.
- 3) Use of non-programmable pocket calculator is permissible.
- 4) Mathematical and other tables shall be made available on request.
- 5) Assume and mention suitable additional data if necessary.
- 6) Use of Mobile is strictly prohibited.
- 7) QN- Question No., SQN-Sub Question No. R- Remembering, U- Understanding, A- Application.

QN	S Q N	Question Text	R/ U/ A	Co	Ma rks
Q.1		Attempt any THREE: (2 X 3)			06
	a)	Evaluate, $\int \frac{1}{2x+5} dx$	R	1	
	b)	Evaluate, $\int \sin^2 x dx$	R	1	
	c)	Evaluate, $\int_0^1 \frac{1}{\sqrt{1-x^2}} dx$	U	2	
	d)	Evaluate, $\int_0^\infty e^{-x} dx$	U	2	
	e)	Solve, $x dy - y dx = 0$	R	3	
Q.2		Attempt any FOUR: (4 X 4)			16
	a)	Evaluate, $\int \frac{1}{\sqrt{3-x-x^2}} dx$	U	1	
	b)	Evaluate, $\int \sin^5 x \cdot \cos x dx$	U	1	
	c)	Evaluate, $\int_1^4 \frac{\sqrt[3]{9-x}}{\sqrt[3]{9-x} + \sqrt[3]{x+4}} dx$	A	2	
	d)	Solve, $3e^x \tan y dx + (1-e^x) \sec^2 y dy = 0$	U	3	
	e)	Evaluate, $\int \frac{\cos x}{(2+\sin x)(3+\sin x)} dx$	U	2	
	f)	Solve, $\frac{dy}{dx} + y \cot x - \operatorname{cosec} x = 0$	U	3	
Q.3		Attempt any TWO: (6 X 2)			12
	a)	Evaluate, i) $\int \frac{\cos x}{4+\sin^2 x} dx$ ii) $\int_{\frac{\pi}{6}}^{\frac{\pi}{4}} \cot^2 x dx$	U	1	
	b)	Solve, $(e^x + 2xy^2) dx + (a^y + 2x^2y + 3xy^2) dy = 0$	U	2	
	c)	Evaluate, $\int \frac{\sec^2 x}{(1+\tan x)(2+\tan x)} dx$	A	1	

P.T.O.

GOVERNMENT POLYTECHNIC, KOLHAPUR – 416004.

(An Autonomous Institute of Govt. Of Maharashtra)

SUMMER-2024

EXAM SEAT NO.

LEVEL :- Third

PROGRAM : **CE/ME/IT/EE/ET/MT**

COURSE CODE :- CCH301

COURSE NAME :- APPLIED MATHEMATICS

MAX. MARKS : 70

TIME : 03 Hrs

DATE :- 21/5/2024

QN	S Q N	Question Text	R/ U/ A	Co	Ma rks
Q.4		Attempt any FOUR : (2 X 4)			08
	a)	Show that the root of the equation $x^3 - 6x + 3 = 0$ lies between 2 and 3.	R	3	
	b)	Solve by using Jacobi's method (only one iteration) $5x + 2y + z = 12, x + 4y + 2z = 15, x + 2y + 5z = 20$	U	3	
	c)	If a random variable has a Poisson's distribution such that $P(2) = P(3)$ then find $P(5)$.	U	4	
	d)	Find $L\{5 + 2t - e^{-2t}\}$	R	5	
	e)	Find $L\{\sin^2 t\}$	U	5	
	f)	Find $L^{-1}\left\{\frac{3s+2}{s^2+4}\right\}$	U	5	
Q.5		Attempt any FOUR : (4 X 4)			16
	a)	Using Bisection method to find the approximate root of the equation $x^3 + 5x + 1 = 0$ (Take 3 iterations only)	A	3	
	b)	Using Regula-Falsi method to find the approximate root of the equation $x^3 + 2x^2 - 8 = 0$ (Take 3 iterations only)	A	3	
	c)	Using Newton Raphson method to evaluate $\sqrt[3]{28}$.	U	3	
	d)	A sample of 1000 bulbs is distributed normally with mean life 1620 hrs and standard deviation 300 hrs. Find the number of bulbs which would die out after a useful life of 900 hrs. For $z = 2.4$ area is 0.4918.	U	4	
	e)	Find $L\{e^{2t} \cos 3t \cdot \sin 2t\}$	U	5	
	f)	Find $L^{-1}\left\{\frac{s+2}{s^2-4s+13}\right\}$	A	5	
Q.6		Attempt any TWO : (6 X 2)			12
	a)	Solve by using Gauss-seidel method (Take only 3 iterations) $2x + y - 2z = 17, 3x + 20y - z = 18, 2x - 3y + 20z = 25$	A	3	
	b)	i) An unbiased coin is tossed 6 times. Find the probability of getting exactly 2 heads. ii) If 3% of electric bulbs manufactured by a company are defective, then find the probability that in a sample of 100 bulbs exactly 5 bulbs are defective.	A	4	
	c)	i) Find $L\{t \cdot e^t \cdot \sin 2t\}$ ii) Find $L^{-1}\left\{\frac{3s+1}{(s-1)(s+1)}\right\}$	A	5	

GOVERNMENT POLYTECHNIC, KOLHAPUR – 416004.

(An Autonomous Institute of Govt. Of Maharashtra)

SUMMER- 2024**EXAM SEAT NO.**

--	--	--	--	--	--

LEVEL :- FIRST

PROGRAM : **CE/ME/MT**

COURSE CODE :- CCG108

COURSE NAME :- ENGINEERING DRAWING-II

MAX. MARKS : 80 TIME : 4 Hrs DATE :- **15/5/2024**

Instruction :-

- 1) Illustrate your answers with sketches wherever necessary.
- 2) Use of non-programmable pocket calculator is permissible.
- 3) Mathematical and other tables shall be made available on request.
- 4) Assume and mention suitable additional data if necessary.
- 5) Use of Mobile is strictly prohibited.
- 6) QN- Question No., SQN-Sub Question No. R- Remembering, U- Understanding, A- Application.

QN	S Q N	Question Text	R/ U/ A	CO	Marks
Q.1		Attempt any TWO :			16
	a)	A hexagonal prism, side of base 30 mm and axis length 50 mm is kept on the V.P. on one of its base corners such that the longer edge passing through that corner makes an angle of 40° to V.P. Axis of the prism is parallel to H.P. Draw the projections of the prism. (Three Views).	U	1	
	b)	Draw the projection of cone having base 50mm diameter and axis 65mm long, lying on the ground (H.P.) on one of its outer generators with its axis parallel to V.P. (Three Views).	U	1	
	c)	A pentagonal pyramid having side 30mm and axis length 65mm long is resting on H.P. on one of its base corners. Draw the projections (three Views) if its slant edge containing that corner makes an angle of 45° with H.P. and its axis is parallel to V.P.	U	1	
Q.2		Attempt any TWO :			16
	a)	A pentagonal prism side of base 40mm and axis 70mm is kept on HP on its base with side of base perpendicular to VP. It is cut by an AIP in such a way that true shape of section is an isosceles triangle of maximum base and altitude 60mm. Draw FV, Sectional TV, and True shape of section.	U	2	
	b)	A cylinder of base diameter 60mm axis 80mm is kept on the HP on its base. It is cut by an AIP in such a way that the true shape of the section is largest possible ellipse. Draw FV, sectional TV, and True shape of section.	U	2	
	c)	A hexagonal pyramid, base 30 mm side and axis 65mm long has its base on HP with an edge of base parallel to VP. A vertical section plane inclined at 45° to VP, cuts the pyramid at a distance of 10 mm from its axis ^{apex} . Draw TV, sectional front view and true shape of section.	U	2	
Q.3		Attempt any FOUR :			08
		Draw free hand sketches of following			
	a)	Internal threads	d)	Eye bolt	R 3
	b)	Dome nut	e)	ACME threads	R 3
	c)	Single rivetted single strap butt joint	f)	Lewis foundation bolt	R 3

GOVERNMENT POLYTECHNIC, KOLHAPUR – 416004.

(An Autonomous Institute of Govt. Of Maharashtra)

SUMMER- 2024**EXAM SEAT NO.**

--	--	--	--	--	--

LEVEL :- **First**PROGRAM : **CE/ME/MT**COURSE CODE :- **CCG108**COURSE NAME :- **Engineering Drawing-II**MAX. MARKS : **80** TIME : **04 Hrs**DATE :- **15/5/2024**

QN	S Q N	Question Text	R/ U/ A	CO CCG 108-	M ar ks
Q.4		Attempt any ONE			08
	a)	Figure 1 Shows FV and TV of an object. a. Redraw FV b. Redraw TV c. Draw LHSV	R & U	4	
	b)	Figure 2 Shows FV and RHSV of an object. a. Redraw FV b. Redraw RHSV c. Draw TV	R & U	4	
Q.5		Attempt any ONE			16
	a)	Figure 3 shows FV and TV of object. Draw Isometric View from it. Consider origin 'O'.	U & A	5	
	b)	Figure 4 shows FV and TV of object. Draw Isometric Projections from it. Consider origin 'O'. Draw isometric scale.	U & A	5	
Q.6		Attempt any TWO			16
	a)	Draw the development of lateral surface of a cylinder of diameter 40 mm and height 60mm kept on HP on its base. It is cut by an AIP 45 degree to HP and bisecting the axis of cylinder.	R & U	6	
	b)	A square prism side of base 45mm and axis length 90mm has its axis vertical and rectangular faces equally inclined to V.P. A square hole of sides 30mm is drilled through the prism completely such that the axis of the hole is perpendicular to V.P. and bisects the axis of vertical square prism. The sides of square hole are equally inclined to H.P. Draw the development of lateral surface with effect of hole.	R & U	6	
	c)	A cone with base diameter 60mm and axis length 70mm rests on its base on H.P. A circular hole of 30mm diameter is drilled through the cone such that its axis perpendicular to V.P., parallel to H.P. and 20mm above the base of cone. Draw the development of the surface showing the effect of the hole if axis of hole is 10mm to the right of the axis of the cone.	U & A	6	

P.T.O.

4/3

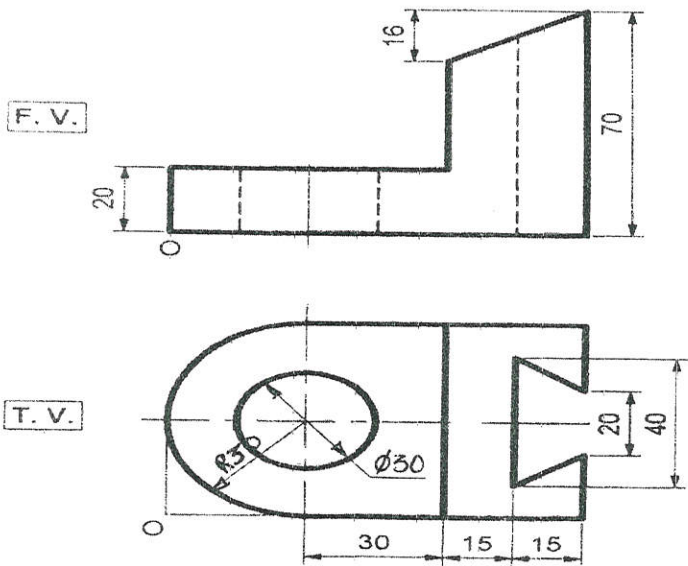

Figure 1 Que 4. a

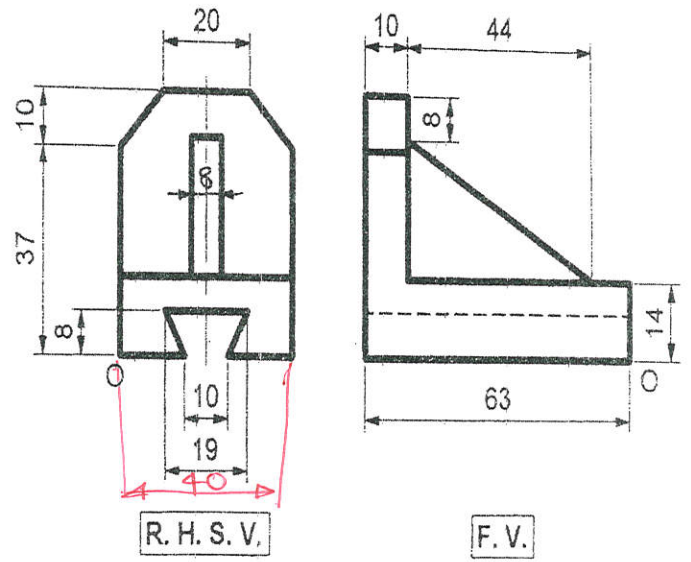

Figure 2 Que 4. b

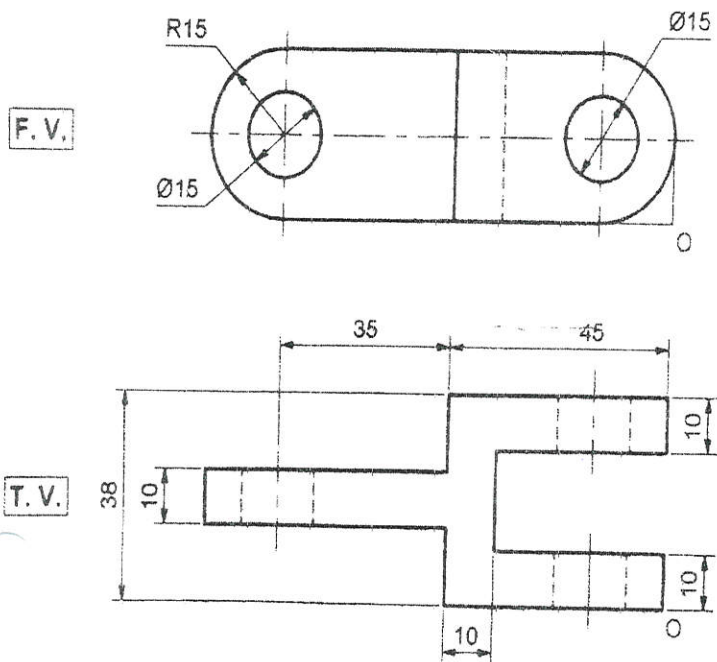

Figure 3 Que 5. a

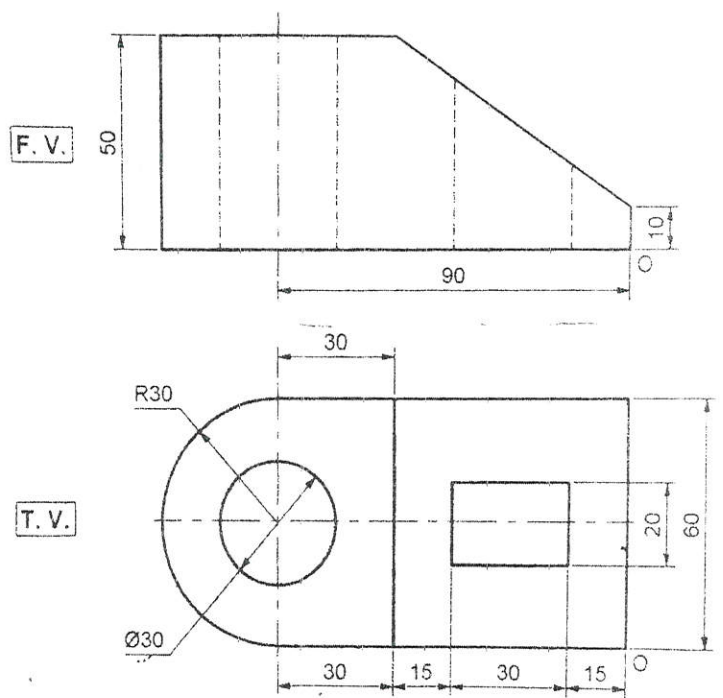

Figure 4 Que 5. b

GOVERNMENT POLYTECHNIC, KOLHAPUR – 416004.

(An Autonomous Institute of Govt. Of Maharashtra)

SUMMER-2024**EXAM SEAT NO.**

--	--	--	--	--	--

LEVEL :- First

PROGRAM : CE/ME/MT

COURSE CODE :- CCH108

COURSE NAME :- APPLIED MECHANICS

MAX. MARKS : 70

TIME : 03 Hrs

DATE :- 11/5/2024

Instructions :-

- 1) Illustrate your answers with sketches wherever necessary.
- 2) Use of non-programmable pocket calculator is permissible.
- 3) Assume and mention suitable additional data if necessary.
- 4) Use of Mobile is strictly prohibited.
- 5) Figures are attached on separate page in question paper as per question and sub question.
- 6) QN- Question No., SQN-Sub Question No. R- Remembering, U- Understanding, A- Application.

QN	S Q N	Question Text	R/ U/ A	CO	Ma rks
Q.1		Attempt any THREE: (2 X 3)			06
	a)	Enlist any two characteristics of couple.	R	CCH111-1	
	b)	State law of polygon of forces.	R	CCH111-1	
	c)	State lami's theorem.	U	CCH111-2	
	d)	Locate centroid of a square lamina of sides 400mm, which is rested on its one corner point .	A	CCH111-2	
	e)	Define angle of repose in dry friction.	R	CCH111-3	
Q.2		Attempt any FOUR: (4 X 4)			16
	a)	A hexagon acted by six forces each side along the regular hexagon taken in clockwise order from base respectively in magnitude 1kN,2kN,3kN,4kN,5kN,6kN, determine magnitude of resultant and position of resultant.	A	CCH111-1	
	b)	Determine position of centroid of a section as shown in figure	A	CCH111-2	
	c)	A sphere weighing 1500 N is supported by two planes making angle 30° and 60° to the horizontal plane, determine support reactions.	U	CCH111-2	
	d)	A block of 300 N is at rest on 30° inclined plane, calculate horizontal force that causes the motion to impend up the plane if coefficient of friction between block and plane is 0.20	A	CCH111-3	
	e)	Determine resultant and its position from point A of force system shown in figure	U	CCH111-1	
	f)	Determine reactions of the overhang beam as shown in figure by analytical method.	A	CCH111-3	
Q.3		Attempt any TWO: (6 X 2)			12
	a)	Determine magnitude of resultant and its position from point 'A' as shown in figure	A	CCH111-1	
	b)	Determine centroid of the reminder portion after cutting a triangular notch of sides 200 mm each from the sheet as shown in figure.	U	CCH111-2	
	c)	A ladder of weight 400N, is rest on smooth wall and rough horizontal floor, making angle of 30° with vertical, if coefficient of friction in floor and ladder is 0.35 i) Draw free body diagram showing all forces ii) Find all active and reactive forces iii) state that will ladder remain stand in position ?	A	CCH111-3	

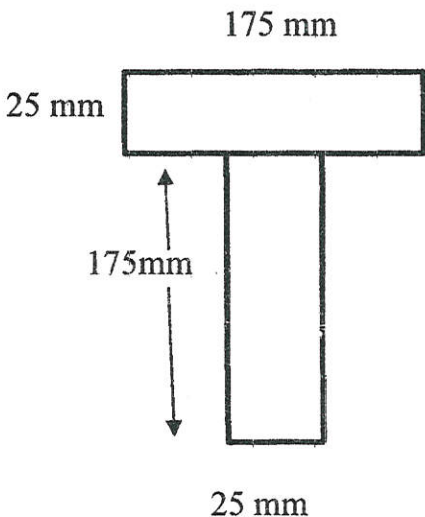
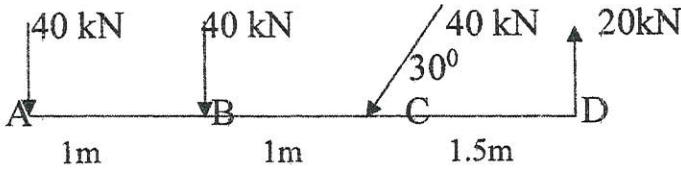
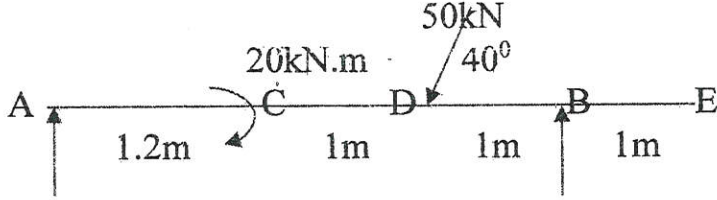
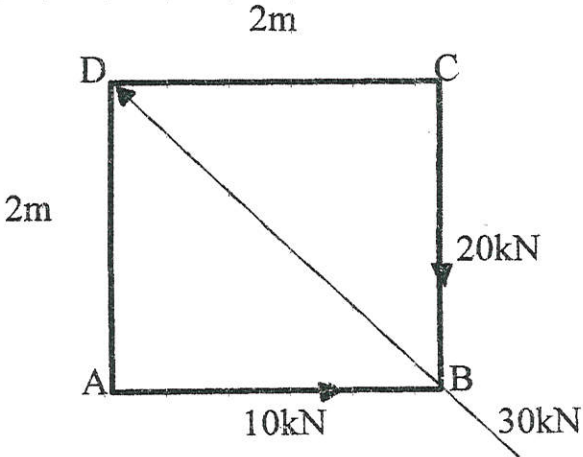
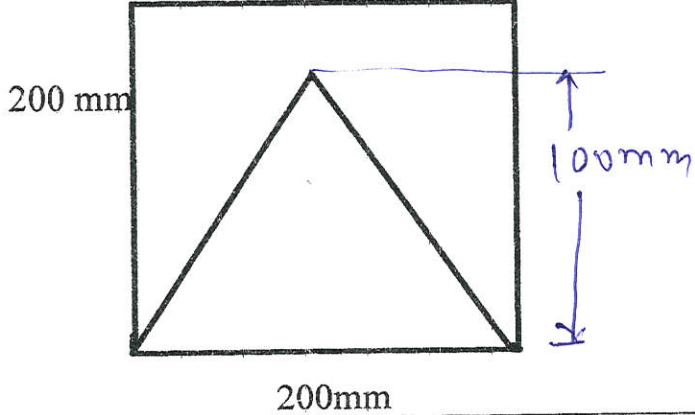
QN	S QN	figures
Q.2	b)	
Q.2	e)	
Q.2	f)	
Q.3	a)	
Q.3	b)	

GOVERNMENT POLYTECHNIC, KOLHAPUR – 416004.

(An Autonomous Institute of Govt. Of Maharashtra)

SUMMER 2024**EXAM SEAT NO.**

--	--	--	--	--	--

LEVEL :- First

PROGRAM : CE/ME/MT

COURSE CODE :- CCH108

COURSE NAME :- APPLIED MECHANICS

MAX. MARKS : 70

TIME : 03 Hrs

DATE :- 11/5/2024

QN	S Q N	Question Text	R/ U/ A	Co	Ma rks
Q.4		Attempt any FOUR: (2 X 4)			08
	a)	Define the ideal machine and ideal effort.	R	4	
	b)	State the D alembert's principle for dynamic equilibrium.	R	5	
	c)	Define kinetics and kinematics.	R	5	
	d)	State any two equations of rectilinear motion when a body is freely falling under gravity.	U	5	
	e)	Define P.E. and K.E. State their equations.	R	6	
	f)	State the work – energy principle.	R	6	
Q.5		Attempt any FOUR: (4 X 4)			16
	a)	State the formula of velocity ratio of differential axle and wheel with neat sketch .	R	4	
	b)	A machine requires an effort of 9N to lift a load of 45N. The velocity ratio machine is 25. Find the load lost due to friction and efficiency of the machine at this load.	U	4	
	c)	In a simple screw jack, the pitch of the screw is 10 mm and length of handle is 450mm. Find V.R. if an effort of 25N is applied at the end of handle can lift the load of 3 KN, find the efficiency of jack. Also calculate the amount of effort wasted in friction.	A	4	
	d)	If a body of mass 200 kg changes velocity of 40 m/s to 10 m/s, calculate the impulse acting on the body.	U	5	
	e)	A car has initial velocity of 3m/s. It accelerates for 12 seconds at the rate of 3.5 m/s ² . Determine the final velocity and the distance travelled during this time.	U	5	
	f)	A cubical water tank has a side of 2m each. It is placed with its base 9m above the ground level. Find the potential energy of the water tank when the tank is full.	U	6	
Q.6		Attempt any TWO: (6 X 2)			12
	a)	For a geared pulley block, the following data is available: No. of cogs on the effort wheel = 60 No. of teeth on the pinion = 10 No. of teeth on the spur = 90 No. of cogs on the load wheel = 15 If the maximum effort required to lift a load is 50N, calculate the maximum load that can be lifted by the machine at 70% efficiency.	A	4	
	b)	A bullet of weight 1N is fired with a velocity of 500 m/s horizontally in a wooden block weighing 50N resting on horizontal surface. If the bullet remains embedded in the block, calculate the velocity of the block after impact.	A	5	
	c)	A water tank of capacity 1000 liters is to be filled in 5 minutes by a pump. Water is required to be lifted through a height of 20 m. If the efficiency of the pump is 70%, find the power of pump.	A	6	

GOVERNMENT POLYTECHNIC, KOLHAPUR – 416004

(An Autonomous Institute of Govt. Of Maharashtra)

SUMMER 2024**EXAM SEAT NO.**

--	--	--	--	--	--

LEVEL : - **First**PROGRAM : **CE/ME /MT**COURSE CODE : **CCG106/CCF106/X110**COURSE NAME : **Engineering Mathematics**MAX. MARKS : **80** TIME : **3 HRS.** DATE :- **10 May 2024**

Instruction :-

- 1) Answers must be written in the main answer book provided (and supplements if required).
- 2) Illustrate your answers with sketches wherever necessary.
- 3) Use of non-programmable pocket calculator is permissible.
- 4) Mathematical and other tables shall be made available on request.
- 5) Assume and mention suitable additional data if necessary.
- 6) Use of Mobile is strictly prohibited.
- 7) QN- Question No., SQN-Sub Question No. R- Remembering, U- Understanding, A- Application.

QN	S Q N	Question Text	R/ U/ A	CO	Marks
Q.1		Attempt any FOUR :			08
	a)	If $2.(3-4i) + 4(2-5i) = x+iy$ then find x & y	R	1	
	b)	Show that $5x + 6y - 1 = 0$ and $6x - 5y + 3 = 0$ are perpendicular lines.	R	2	
	c)	Find the equation of straight line passing through (4,-5) & having slope $-2/3$	R	2	
	d)	Two cards are drawn from a pack of cards .Find the probability that they will be both red or both pictures.	U	3	
	e)	If X is Binomially distributed with $E(X)=2$ & $\text{var.}(X)=4/3$,find the probability distribution of X.	A	4	
	f)	In a sample of 100 bulbs ,if 5% of the electric bulbs are defective ,using Poisson distribution ,find mean of the distribution.	A	4	
Q.2		Attempt any FOUR :			16
	a)	Using De'Moiver's theorem , simplify $\frac{(\cos 2\theta + i \sin 2\theta)(\cos \theta - i \sin \theta)^4}{(\cos 3\theta - i \sin 3\theta)^2 (\cos 5\theta + i \sin 5\theta)^{-3}}$	A	1	
	b)	Find the equation of a line passing through the point of intersection of the lines $2x+3y=13$, $5x-y=7$ & passing through (1,-1)	U	2	
	c)	Find the distance between two parallel straight lines $3x+2y-6=0$, $3x+2y-12=0$	R	2	
	d)	If the mean life time & S. D. of battery cells are 12 hrs & 3 hrs . What % of batteries will have life i) between 10 & 14 hrs ii) more than 15 hrs iii) Less than 6 hrs	A	4	

e)	Find the probability that at most 4 defective bulbs will be found in a box of 200 bulbs if it is known that 2 percent of the bulbs are defective.(Given : $e^{-4}=0.0183$)	A	4	
f)	A box contains 3 white & 4 black balls .Another box contains 4 white & 5black balls. If one ball is selected from each box ,what is the probability that a) two balls are of the same colour . b) Two balls are of different colours .	A	3	
Q.3	Attempt any FOUR :			16
a)	Prove that : $(1+i)^n + (1-i)^n = 2^{n+1} \cdot \cos\left(\frac{n\pi}{4}\right)$ hence show that $(1+i)^{12} + (1-i)^{12} = -128$	A	1	
b)	Simplify : $\frac{1+2i}{-6-i}$	U	1	
c)	Find the length of the perpendicular from the point (2,3) on the line $4x-6y-3=0$	R	2	
d)	A manufacture of Pins knows that on an average 5% his product is defective . He sells pins in boxes of 100 & guarantees that no more than 4 pins will be defective . In how many boxes out of 1000 ,he will meet the guaranteed quality.	A	4	
e)	For a normal variate with mean 2.5 & standard deviation 3.5 find the probability that i) $2 \leq x \leq 4.5$ ii) $-1.15 \leq x \leq 5.5$	A	4	
f)	If $P(A) = \frac{1}{2}, P(A \cap B) = \frac{1}{6}, P(A \cup B) = \frac{7}{12}$ find a) $P(B)$, b) $P((A' \cup B')$	A	3	

QN	S Q N	Question Text	R/ U/ A	Co CCG 106/ 118	M ar ks
Q.4		Attempt any FOUR :			08
	a)	If $f(x) = \sin x$ then show that $f(3x) = 3.f(x) - 4[f(x)]^3$	R	5	
	b)	Evaluate $\lim_{x \rightarrow 1} \left[\frac{1}{x-1} - \frac{1}{x^2-x} \right]$	R	5	
	c)	Find $\frac{dy}{dx}$ if $y = e^x \cdot \sin x$	R	6	
	d)	Find $\frac{dy}{dx}$ if $y = \cos(x e^x)$	R	6	
	e)	If $\tan^{-1}(x^2 + y^2) = a^2$ then find $\frac{dy}{dx}$.	U	6	
	f)	At which point on the curve $y = 3x - x^2$, the slope is -5.	A	6	
Q.5		Attempt any FOUR :			16
	a)	If $f(x) = x^2 - 3x + 4$ then find x for which $f(1-x) = f(2x+1)$	A	5	
	b)	Evaluate $\lim_{x \rightarrow 3} \left[\frac{\sqrt{2x+3} - \sqrt{4x-3}}{x^2-9} \right]$	U	5	
	c)	If $y = (\sin x)^{\cos x}$ then find $\frac{dy}{dx}$.	U	6	
	d)	If $e^y = y^x$ then prove that $\frac{dy}{dx} = \frac{(\log y)^2}{\log y - 1}$.	A	6	
	e)	If $y = e^{m \sin^{-1} x}$ then prove that $(1-x^2) \frac{d^2 y}{dx^2} - x \frac{dy}{dx} - m^2 y = 0$	A	6	
	f)	Find the equation of tangent and normal to the curve $y = x^3 - 2x^2 + 4$ at $x = 2$	A	6	
Q.6		Attempt any FOUR :			16
	a)	If $f(x) = \frac{x+5}{3x-4}$ & $t = \frac{5+4x}{3x-1}$ then show that $f(t) = x$	A	5	
	b)	Evaluate $\lim_{x \rightarrow \infty} \sqrt{x^2 + x + 1} - x$	A	5	
	c)	If $y = \sin^{-1} \left(\frac{2x}{1+x^2} \right)$ then find $\frac{dy}{dx}$.	A	6	
	d)	If $y = x^x + 5^x + x^5 + 5^5$ then find $\frac{dy}{dx}$.	A	6	
	e)	If $x = a(\theta + \sin \theta)$, $y = a(1 + \cos \theta)$ then find $\frac{d^2 y}{dx^2}$ at $\theta = \frac{\pi}{2}$	A	6	
	f)	Find the maximum and minimum values of $y = 2x^3 - 9x^2 + 12x + 5$	A	6	

GOVERNMENT POLYTECHNIC, KOLHAPUR – 416004

(An Autonomous Institute of Govt. Of Maharashtra)

SUMMER 2024

EXAM SEAT NO.

--	--	--	--	--	--

LEVEL : - **First**

PROGRAM : **COMMON**

COURSE CODE : **CCG110/CCF110**

COURSE NAME : **Applied Mechanics**

MAX. MARKS : **80** TIME : **3 HRS.** DATE :- **11 May 2024**

Instruction :-

- 1) Answers must be written in the main answer book provided (and supplements if required).
- 2) Illustrate your answers with sketches wherever necessary.
- 3) Use of non-programmable pocket calculator is permissible.
- 4) Mathematical and other tables shall be made available on request.
- 5) Assume and mention suitable additional data if necessary.
- 6) Use of Mobile is strictly prohibited.
- 7) QN- Question No., SQN-Sub Question No. R- Remembering, U- Understanding, A- Application.

QN	S Q N	Question Text	R/ U/ A	CO	Mar ks
Q.1		Attempt any FOUR :			08
	a)	State the characteristics of the force.	R	1	
	b)	Enlist with sketches four types of beam.	U	2	
	c)	State the principle of transmissibility of a force.	R	1	
	d)	Differentiate between resultant and equilibrant force.	U	2	
	e)	Define coefficient of Friction.	R	2	
	f)	Define Angle of static friction & dynamic friction.	R	2	
Q.2		Attempt any FOUR :			16
	a)	The four forces 10N, 20N, 15N, & 25N are acting on a point (all push type) at 0° , 50° , 180° & 270° respectively. Calculate two rectangular components of each force.	A	1	
	b)	Calculate the moment about point 'B' for the force system as shown in fig No.1	A	1	
	c)	A sphere weighing 200N supported by two planes inclined at 30° and 60° to the horizontal respectively. Calculate the reactions at the plane.	A	2	
	d)	A simply supported beam of span 6m has two concentrated loads of 8KN and 10KN at 2m and 4m from left hand support, Find the reaction at the two supports.	A	2	
	e)	A block weighing 500N is resting on rough horizontal surface having $\mu=0.30$. It is just moved by a force p inclined at 25° to the horizontal. Calculate force 'P'.	A	2	
	f)	Find graphically magnitude, directions and position of the resultant force of a system of parallel unlike forces as shown in fig.2 From 'A'.	A	3	

PTO Y4

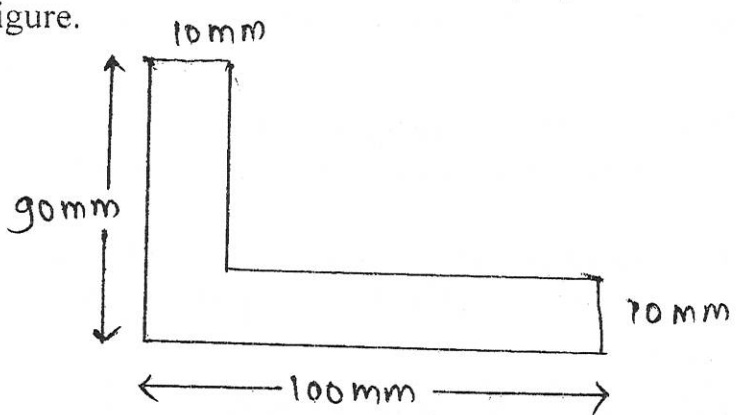
Q.3	Attempt any FOUR :			16
a)	Explain with neat sketch Law of Parallelogram of forces.	U	1	
b)	For a concurrent force system shown in fig No.3 ,Obtain magnitude and directions of it's resultant using analytical method.	A	1	
c)	For a beam ,loaded as shown in fig no. 4 .Calculate the support reactions at A & B using analytical method.	A	2	
d)	A block of weight 600N is resting on a plane inclined at 30° to the horizontal. Find the force that can be applied on the block at an angle of 25° with inclined plane so that the block is just on the point of motion up the plane, the Coefficient of friction between the body and the plane is 0.2.	A	2	
e)	A uniform ladder of weight 300N rest against a smooth vertical wall and a rough horizontal floor making an angle of 60° with the horizontal. The Coefficient of static friction at the floor is 0.30. Find reaction at wall and calculate force of friction also.	A	2	
f)	State the advantages & limitations of Graphical method .Also state the graphical condition of equilibrium for i) concurrent force system ii) Non concurrent force system.	U	3	
Q.4	Attempt any FOUR :			08
a)	Define Centroid.	R	4	
b)	A equilateral triangle of sides 400mm is rested on the base then locate centroid.	A	4	
c)	Calculate angular velocity of a minute hand of clock.	A	5	
d)	Define energy & state its unit.	R	5	
e)	Define ideal machine.	R	6	
f)	If law of machine is $P = 0.25w + 2N$, then state meaning of each term of this law.	U	6	
Q.5	Attempt any TWO :			16
a)	Determine centroid of the following figure & locate in the figure. 	A	4	
b)	A motor car moving with uniform acceleration passes distance 100m, at start velocity was 45kmph & at the point when it reaches 100m was 54kmph, then find i) acceleration of the car ii) time taken to travel 100m iii) number of revolutions made by the wheels of the car during it's travel of 100m ,diameter of wheel is 500mm. iv) distance travelled in the 2 minutes from the start, if same uniform acceleration.	A	5	

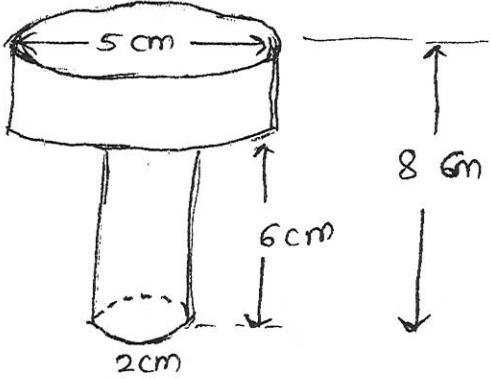
	<p>c) In a simple lifting machine 1.5kw effort is to be moved through a distance of 7.2 m & load 24KN through distance 0.300m ,then determine i) Mechanical advantage ii) velocity ratio ii)efficiency in % iv) ideal effort v) effort lost in friction vi) load lost in friction vii) ideal load viii) state machine is reversible or not?</p>	A	6							
Q.6	Attempt any TWO :			16						
	<p>a) Determine center & gravity of the body as shown in the figure.</p> 	A	4							
	<p>b) i) A disc rotating at 30rps retards uniformly & rotates at 15rps on completing 540 revolutions .Find the time taken & the angular retardation. ii) A cube of size 1m X 1m X 1m weights 500N is displaced by 3 meter by toppling of cube , then calculate it's work done.</p>	A	5							
	<p>c) In a lifting machine observations are as the follows i)</p> <table border="1" data-bbox="240 1385 483 1522"> <tr> <td>Load</td> <td>effort</td> </tr> <tr> <td>3000N</td> <td>400N</td> </tr> <tr> <td>5000N</td> <td>640N</td> </tr> </table> <p>ii) Velocity ratio = 16</p> <p>then determine i) Law of machine ii) How much load can be lifted with an effort of 760N? iii) Maximum efficiency & maximum mechanical advantage . iv) If suddenly effort is removed then whether the load comes down or not?</p>	Load	effort	3000N	400N	5000N	640N	A	6	
Load	effort									
3000N	400N									
5000N	640N									

P.T.O. 3/4

fig No 1
Q. NO 2 (b)

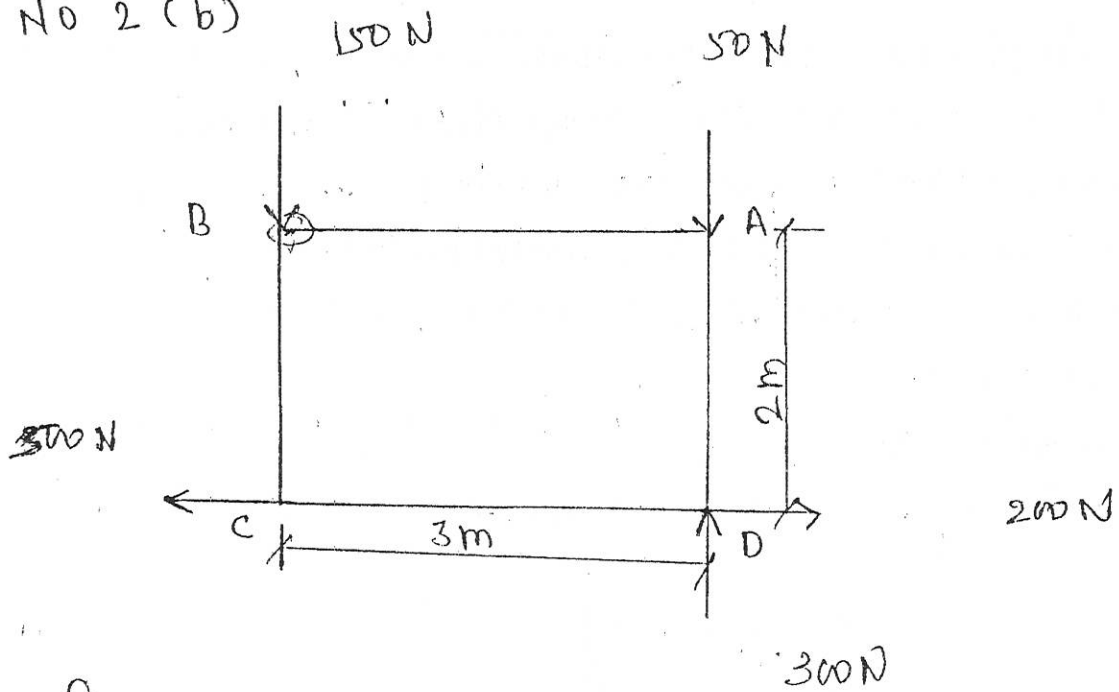

fig No 2
Q NO 2 (f).

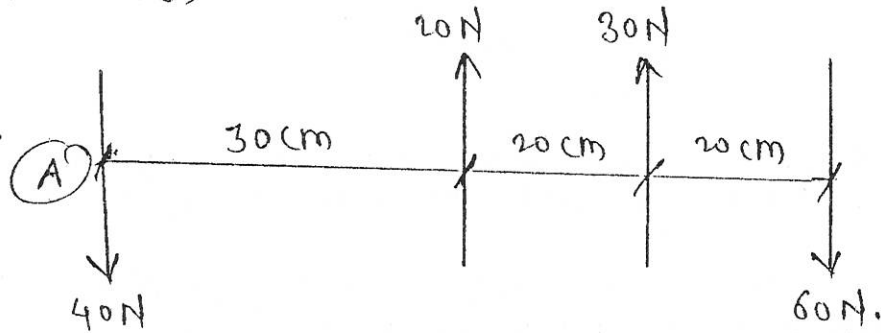

fig No 3
Q 3 (b).

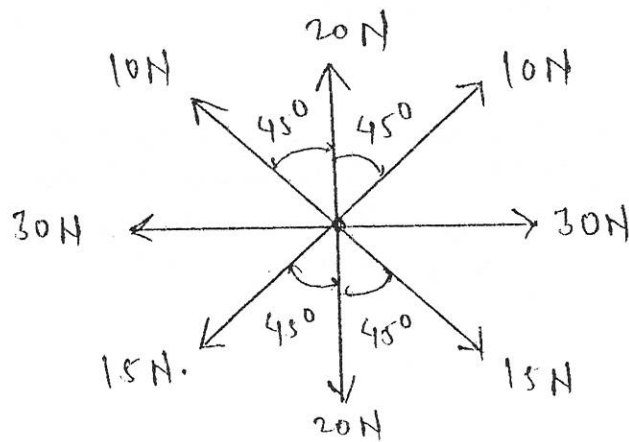
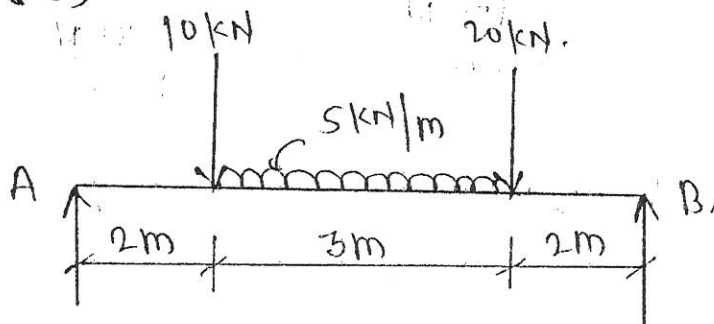

fig No-4

Q 3 (c)



GOVERNMENT POLYTECHNIC, KOLHAPUR – 416004

(An Autonomous Institute of Govt. Of Maharashtra)

SUMMER 2024**EXAM SEAT NO.**

--	--	--	--	--	--

LEVEL :- **First**PROGRAM : **EE/IE/E&TC/IT**COURSE CODE : **CCG118/CCF106**COURSE NAME : **Engineering Mathematics**MAX. MARKS : **80** TIME : **3 HRS.** DATE :- **10 May 2024**

Instruction :-

- 1) Answers must be written in the main answer book provided (and supplements if required).
- 2) Illustrate your answers with sketches wherever necessary.
- 3) Use of non-programmable pocket calculator is permissible.
- 4) Mathematical and other tables shall be made available on request.
- 5) Assume and mention suitable additional data if necessary.
- 6) Use of Mobile is strictly prohibited.
- 7) QN- Question No., SQN-Sub Question No. R- Remembering, U- Understanding, A- Application.

QN	S Q N	Question Text	R/ U/ A	CO	Mar ks
Q.1		Attempt any FOUR :			08
	a)	Express $\frac{2+i}{2-i}$ in the form $a+ib$	R	1	
	b)	If $(3+i)x+(1-i)y=1+7i$, Find x & y	R	1	
	c)	Find the slope and x-intercept of the straight line $\frac{x}{4}-\frac{y}{3}=2$	R	2	
	d)	Find the value of k if the lines $kx-6y=9$ and $6x+5y=13$ are perpendicular to each other.	U	2	
	e)	Find the angle between the lines $3x+2y=6$ and $2x-3y=5$.	A	2	
	f)	Find the first iteration by using Jacobi's method for following system of equations. $10x+y+2z=13$, $3x+10y+z=14$, $2x+3y+10z=15$	R	3	
Q.2		Attempt any FOUR :			16
	a)	Convert into polar form $z = \frac{-1}{2} + \frac{\sqrt{3}}{2}i$	U	1	
	b)	Find the length of perpendicular from (2,3) to the line $4x-6y-3=0$	U	2	
	c)	Find the root of the equation $x^3-4x+1=0$ using Bisection method (upto 3 iterations)	A	3	
	d)	Using Regular Falsi method find the approximate root of $xe^x-3=0$ (take 3 iterations)	A	3	
	e)	Solve by Jacobi's method (3 iterations only) $10x+y+2z=13$, $3x+10y+z=14$, $2x+3y+10z=15$	A	3	
	f)	Solve the following system of equations by Gauss Seidal method $2x+y+z=4$, $x+2y+z=4$, $x+y+2z=4$	A	3	

PTO

Q.3	Attempt any FOUR :			16
a)	Simplify using DeMoivre's Theorem $\frac{(\cos 3\theta + i \sin 3\theta)^4 (\cos 5\theta - i \sin 5\theta)^4}{\left(\cos \frac{9}{2}\theta + i \sin \frac{9}{2}\theta\right)^3 \left(\cos \frac{4}{5}\theta + i \sin \frac{4}{5}\theta\right)^{10}}$	Λ	1	
b)	Find the modulus and amplitude of $z = 1 - \cos \alpha + i \sin \alpha$	Λ	1	
c)	Find the equation of line passing through the intersection of lines $4x + 3y = 8, x + y = 1$ and parallel to the line $5x - 7y = 3$	Λ	2	
d)	Find the root of equation $xe^x = 1$ by using Bisection method . (3 iterations only)	Λ	3	
e)	Solve by Jacobi's method $x + 17y - 2z = 48, 30x - 2y + 3z = 75, 2x + 2y + 18z = 30$	Λ	3	
f)	Solve the following system of equation by Gauss-seidal iteration method. $10x + 2y + z = 9, 2x + 20y - 2z = -44, -2x + 3y + 10z = 22$	Λ	3	
Q.4	Attempt any FOUR :			08
a)	If $f(x) = \sin x$ then show that $f'(3x) = 3f'(x) - 4[f'(x)]^3$	R	5	
b)	Evaluate $\lim_{x \rightarrow 1} \left[\frac{1}{x-1} - \frac{1}{x^2-x} \right]$	R	5	
c)	Find $\frac{dy}{dx}$ if $y = e^x \cdot \sin x$	R	6	
d)	Find $\frac{dy}{dx}$ if $y = \cos(x e^x)$	R	6	
e)	If $\tan^{-1}(x^2 + y^2) = a^2$ then find $\frac{dy}{dx}$.	U	6	
f)	At which point on the curve $y = 3x - x^2$, the slope is -5.	Λ	6	
Q.5	Attempt any FOUR :			16
a)	If $f(x) = x^2 - 3x + 4$ then find x for which $f(1-x) = f(2x+1)$	Λ	5	
b)	Evaluate $\lim_{x \rightarrow 3} \left[\frac{\sqrt{2x+3} - \sqrt{4x-3}}{x^2-9} \right]$	U	5	
c)	If $y = (\sin x)^{\cos x}$ then find $\frac{dy}{dx}$.	U	6	
d)	If $e^y = y^x$ then prove that $\frac{dy}{dx} = \frac{(\log y)^2}{\log y - 1}$.	Λ	6	
e)	If $y = e^{m \sin^{-1} x}$ then prove that $(1-x^2) \frac{d^2 y}{dx^2} - x \frac{dy}{dx} - m^2 y = 0$	Λ	6	
f)	Find the equation of tangent and normal to the curve $y = x^3 - 2x^2 + 4$ at $x = 2$	Λ	6	
Q.6	Attempt any FOUR :			16
a)	If $f(x) = \frac{x+5}{3x-4}$ & $t = \frac{5+4x}{3x-1}$ then show that $f(t) = x$	Λ	5	
b)	Evaluate $\lim_{x \rightarrow \infty} \sqrt{x^2 + x + 1} - x$	Λ	5	
c)	If $y = \sin^{-1} \left(\frac{2x}{1+x^2} \right)$ then find $\frac{dy}{dx}$.	Λ	6	
d)	If $y = x^x + 5^x + x^5 + 5^5$ then find $\frac{dy}{dx}$.	Λ	6	
e)	If $x = a(\theta + \sin \theta), y = a(1 + \cos \theta)$ then find $\frac{d^2 y}{dx^2}$ at $\theta = \frac{\pi}{2}$	Λ	6	
f)	Find the maximum and minimum values of $y = 2x^3 - 9x^2 + 12x + 5$	Λ	6	

GOVERNMENT POLYTECHNIC, KOLHAPUR – 416004,

(An Autonomous Institute of Govt. of Maharashtra)

WINTER / SUMMER-2024

EXAM SEAT NO.

--	--	--	--	--	--	--

LEVEL: - First

PROGRAM: ME/MT

COURSE CODE: - CCH110

COURSE NAME: - Engineering Drawing

MAX. MARKS: 70

TIME: 04Hrs

DATE: - 04 / 05 / 2024

Instruction :-

- 1) Answers of two sections must be written in separate section answer book provided.
- 2) Illustrate your answers with sketches wherever necessary.
- 3) Use of non-programmable pocket calculator is permissible.
- 4) Mathematical and other tables shall be made available on request.
- 5) Assume and mention suitable additional data if necessary.
- 6) Use of Mobile is strictly prohibited.
- 7) QN- Question No., SQN-Sub Question No. R- Remembering, U- Understanding, A- Application.

QN	S Q N	SECTION -I	R/ U/ A	CO	Marks
Q.1		Attempt any TWO: (2 X 8M)			16
	a)	A pentagonal prism base side 25mm and axis length 60mm is standing on a corner of the base on H.P with its axis inclined at 45° to H.P. and parallel to V.P. Draw its projections.	U & A	CCH110 -01	
	b)	A cone base diameter 40mm and axis length 60mm is lying on one of its generators on V.P. with its axis parallel to H.P. Draw its projections.	U & A	CCH110 -01	
	c)	A tetrahedron of 60mm long edges has one edge in H.P. with that edge perpendicular to V.P. and the triangular face containing that edge is vertical (90°). Draw its three views.	U & A	CCH110 -01	
Q.2		Attempt any TWO: (2 X 9M)			18
	a)	Figure No. 1 Shows FV and TV of an object. Draw its isometric View. Consider 'O' as origine.	U & A	CCH110 -02	
	b)	Figure No.2 Shows FV and LHSV of an object. Draw its isometric projection. Draw Isometric scale. Consider 'O' as origine.	U & A	CCH110 -02	
	c)	Figure No. 3 Shows FV and TV of an object. Draw its isometric projection. Draw Isometric scale. Consider 'O' as origine.	U & A	CCH110 -02	

Y4

PTO -

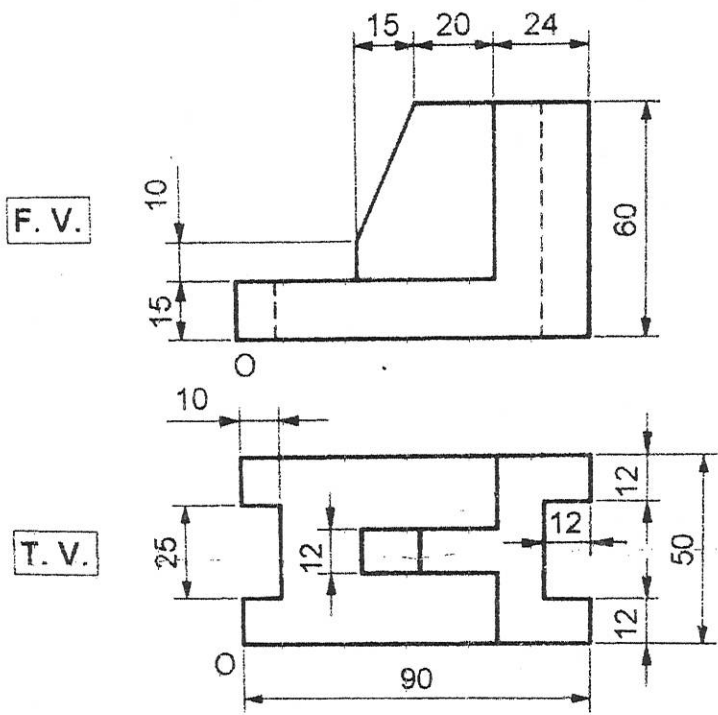

Figure No. 1

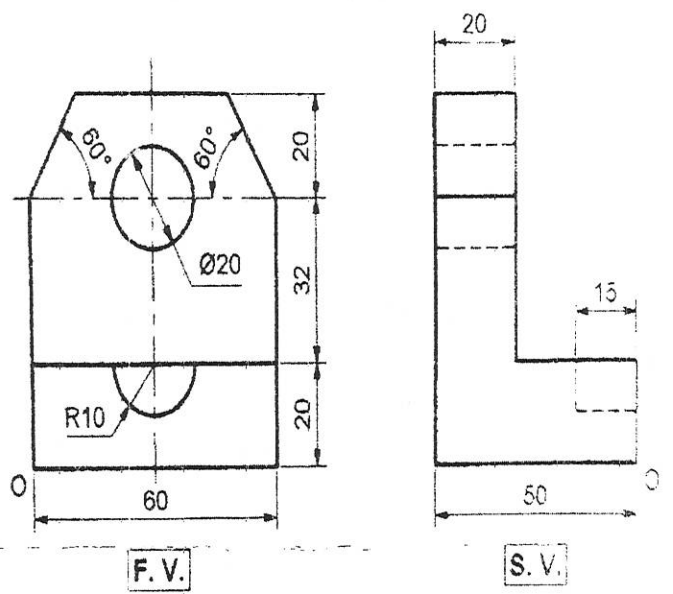

Figure No. 2

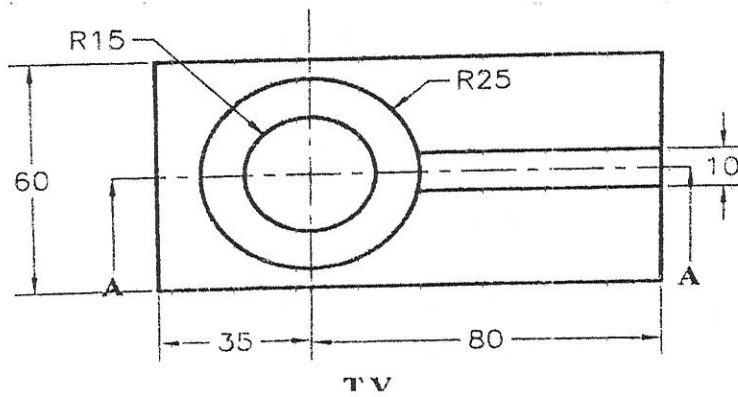
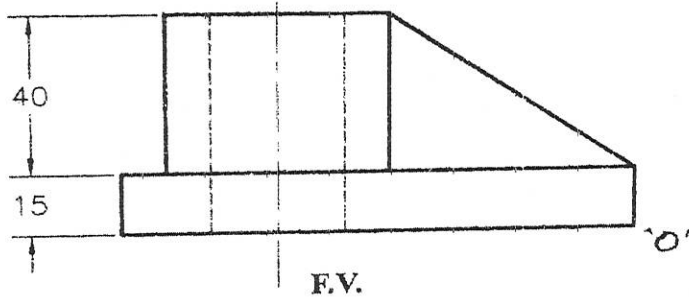

Figure No. 3

2/4

P.T.O.

GOVERNMENT POLYTECHNIC, KOLHAPUR – 416004.

(An Autonomous Institute of Govt. Of Maharashtra)

SUMMER- 2024

EXAM SEAT NO.

LEVEL: - **First**

PROGRAM: **ME/MT**

COURSE CODE: - **CCH110**

COURSE NAME: - **ENGINEERING DRAWING**

MAX. MARKS: **70**

TIME: **4 Hrs**

DATE: **-04/05/2024.**

QN	S Q N	Question Text	R/ U/ A	Co	Ma rks
Q.3		Attempt any TWO: (7 X 2)			14
	a)	<p>Figure No. 4 shows Front and Top view of an object. Draw the following views using first angle method: (i) Front View (ii) Top view (iii) Left hand side view.</p> <div style="text-align: center;"> </div> <p align="center">Figure No. 4</p>	U	3	7
	b)	<p>Draw the following views of an object shown in Figure No. 5, use first angle method: (i) Sectional Front View (ii) Top view (iii) Left hand side view.</p> <div style="text-align: center;"> </div> <p align="center">Figure No. 5</p>	U	3	7

- c) Figure No.6 shows front view and top view of the object. Draw the following views of the object. (Use first angle method): (i) Front view (ii) Top view (iii) LHSV.

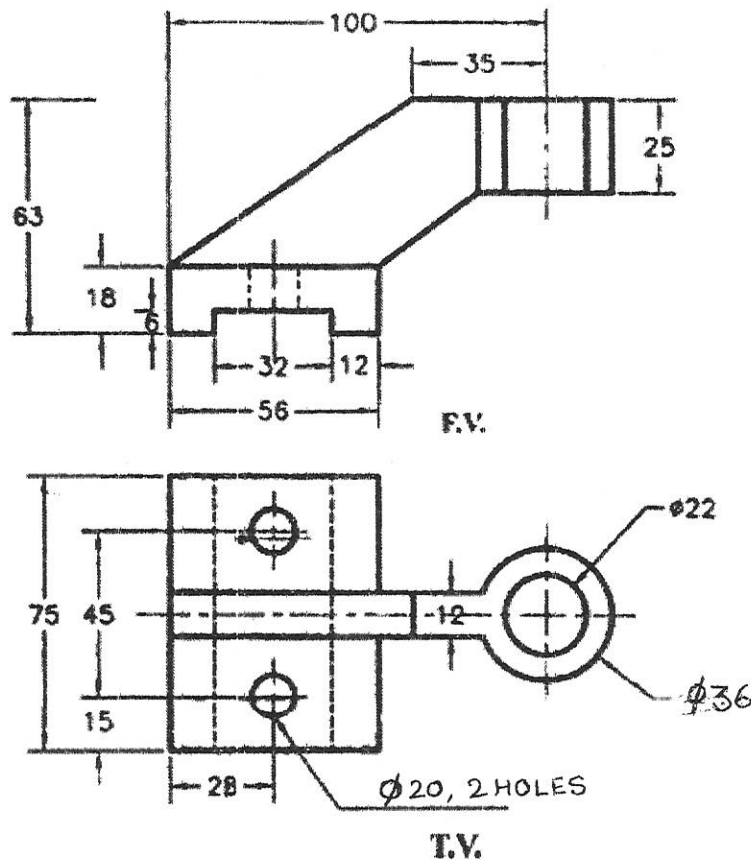

Figure No. 6

Q.4 Attempt any **TWO: (6 X 2)**

- a) Draw development of surface of a cylinder having base diameter 50 mm and axis height 80 mm kept of HP. It is cut by a cutting plane which is inclined at 45° with HP and bisecting axis of cylinder.

- b) A square prism of base side 40 mm and axis height 90 mm is rest on HP such that its side of base equally inclined with VP. A circular hole of diameter ~~35~~ 45 mm is drilled through prism such that axis of hole is perpendicular to VP and parallel to HP and bisect axis of square prism. Draw development of surface of prism.

- c) Figure No. 7 shows FV of a square pyramid. Draw the development of lateral surfaces of a pyramid.

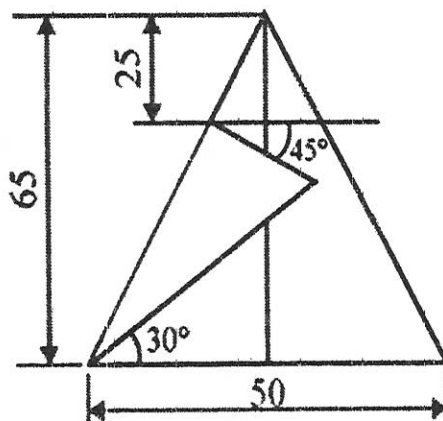

Fig No. 7

Q.5 Attempt any **FIVE: (2 X 5)**

- a) Draw neat and proportionate freehand sketch of Rag foundation bolt.
- b) Draw conventional representation of Withworth thread.
- c) Draw neat and proportionate freehand sketch of Hexagonal nut.
- d) Draw neat and proportionate freehand sketch of Eye bolt.
- e) Draw the conventional representation Double rivetted lap joint.
- f) Draw neat and proportionate freehand sketch of Lock nut.
- g) Draw neat and proportionate freehand sketch of Plain washer.

GOVERNMENT POLYTECHNIC, KOLHAPUR – 416004

(An Autonomous Institute of Govt. Of Maharashtra)

SUMMER 2024**EXAM SEAT NO.**

--	--	--	--	--	--

LEVEL :- **First**PROGRAM : **EE/IT/E&TC/IE**COURSE CODE : **CCG104/CCF103**COURSE NAME : **Engineering Chemistry-**MAX. MARKS : **80** TIME : **3 HRS.** DATE :- **04 May 2024**

Instruction :-

- 1) Answers must be written in the main answer book provided (and supplements if required).
- 2) Illustrate your answers with sketches wherever necessary.
- 3) Use of non-programmable pocket calculator is permissible.
- 4) Mathematical and other tables shall be made available on request.
- 5) Assume and mention suitable additional data if necessary.
- 6) Use of Mobile is strictly prohibited.
- 7) QN- Question No., SQN-Sub Question No. R- Remembering, U- Understanding, A- Application.

QN	S Q N	Question Text	R/ U/ A	CO	Mar ks
Q.1		Attempt any FOUR :			08
	a)	State Aufbau's principle.	R	1	
	b)	Define 1)Isotopes 2) Isobars	R	1	
	c)	Define 1)conductors 2)Electrolyte	R	1	
	d)	Define promotors with examples .	R	3	
	e)	Explain types of corrosion.	U	2	
	f)	Enlist types of Polymerization with definitions.	R	3	
Q.2		Attempt any FOUR :			16
	a)	Explain formation of H ₂ O molecules .	U	1	
	b)	Explain with labelled diagram electrolysis of CuSO ₄ solution using Cu electrode.	U	1	
	c)	Distinguish between galvanizing and tinning.	U	2	
	d)	Explain factors affecting atmospheric corrosion.	U	2	
	e)	Distinguish between homogenous and heterogenous catalyst.	U	3	
	f)	Explain preparation ,properties and uses of glass wool.	U	3	
Q.3		Attempt any FOUR :			16
	a)	Explain Bohr's theory of atom with diagram.	U	1	
	b)	State two properties and engineering applications of rubber.	U/A	3	
	c)	Define adhesive and explain characteristics of good adhesive.	U/A	3	
	d)	Explain with classification ,properties and uses of composite material.	U	3	
	e)	Explain engineering properties and applications of plastic.	U	3	
	f)	Explain Arrhenius theory of ionization.	U	1	

QN	S Q N	Question Text	R/ U/ A	Co MEF 503	Mar ks
Q.4		Attempt any FOUR :			08
	a)	Define sterilization. Enlist different types of chlorination.	U	4	
	b)	Explain two advantages of H ₂ - O ₂ fuel cell.	A	1	
	c)	Define primary & secondary battery.	U	1	
	d)	Explain occurrence of metals.	R	5	
	e)	Define Gangue & Flux.	R	5	
	f)	Memorize composition of soft solder.	U	6	
Q.5		Attempt any FOUR :			16
	a)	Distinguish between temporary and permanent hardness.(Any four points.)	U	4	
	b)	Explain disadvantages of Hard water in Paper Industry & Textile Industry.	A	4	
	c)	Explain construction & working of Dry Cell.	A	1	
	d)	Distinguish between calcination & Roasting. (4 points)	A	5	
	e)	Explain with diagram Gravity separation method.	U	5	
	f)	Enlist composition & two properties of brazing alloy & Plumber's solder.	R	6	
Q.6		Attempt any FOUR :			16
	a)	Explain Ion exchange method to remove total hardness of water.	A	4	
	b)	Distinguish between hard water & soft water. .(Any four points.)	U	4	
	c)	Define -Discharge ,Internal resistance ,Closed Circuit Voltage & E. M. F.	R	1	
	d)	Explain construction & working of Lead acid storage battery while charging.	U	1	
	e)	Explain smelting process of extraction of copper from copper pyrites.	U	5	
	f)	Enlist four properties & four uses of copper.	R	5	

GOVERNMENT POLYTECHNIC, KOLHAPUR – 416004.

(An Autonomous Institute of Govt. Of Maharashtra)

EVEN TERM END EXAM SUMMER -2024**EXAM SEAT NO.**

--	--	--	--	--	--	--

LEVEL :- **FIRST**PROGRAM : **CE/ME/MT**COURSE CODE :- **CCG103/CCF103**COURSE NAME **ENGINEERING CHEMISTRY**MAX. MARKS : **80** TIME : **03Hrs.**DATE :- **04/05/2024**

Instruction :-

- 1) Answers must be written in the main answer book provided.(and supplements if required)
- 2) Illustrate your answers with sketches wherever necessary.
- 3) Use of non-programmable pocket calculator is permissible.
- 4) Mathematical and other tables shall be made available on request.
- 5) Assume and mention suitable additional data if necessary.
- 6) Use of Mobile is strictly prohibited.
- 7) QN- Question No., SQN-Sub Question No. R- Remembering, U- Understanding, A- Application.

QN	S Q N	Question Text	R/ U/ A	Co CCG 103	Mar ks
Q.1		Attempt any FOUR :			08
	a)	Define atom.	R	1	
	b)	Distinguish between atomic number and atomic mass number.	U	1	
	c)	Define electrolysis	R	2	
	d)	What is degree of ionisation?	U	2	
	e)	Define catalyst.	R	3	
	f)	State different types of catalyst.	R	3	
Q.2		Attempt any FOUR :			16
	a)	Explain Bohr's theory of atom.	U	1	
	b)	State the applications of electrolysis and explain any one of them.	U	2	
	c)	Explain the formation of CaCl ₂ molecule on the basis of electrovalency .	U	1	
	d)	With neat labelled diagram explain the electrolysis of molten NaCl.	U	1	
	e)	Define corrosion. Explain atmospheric corrosion.	U	2	
	f)	Explain the process used for protection of large and irregular shaped articles from corrosion.	A	2	
Q.3		Attempt any FOUR :			16
	a)	Write the characteristics of good insulator.	U	3	
	b)	State the properties and uses of Glass wool.	U	3	
	c)	What are composite materials? Write their properties and uses.	U	3	
	d)	Distinguish between polymerisation by addition and polymerization by condensation.	U	3	
	e)	Explain vulcanization of rubber.	U	3	
	f)	Write the properties and uses of adhesives.	U	3	

P.T.O

QN	S Q N	Question Text	R/ U/ A	Co CCG 103	M ar ks
Q.4		Attempt any FOUR :			08
	a)	Name the chemicals used for regeneration of cation exchange resin and anion exchange resin.	R	4	
	b)	Define Lubricant and Lubrication.	R	6	
	c)	Give composition of woods metal.	U	3	
	d)	List out any two ores of iron with their chemical formulae.	R	5	
	e)	What is temporary and permanent hardness of water?	U	4	
	f)	List out the various constituents of Paints.	R	2	
Q.5		Attempt any FOUR :			16
	a)	How the terms flux and gangue are complementary to each other? Explain with chemical equations.	A	4	
	b)	Write characteristics of good lubricant.	U	6	
	c)	What is Soap? Explain reaction of hard water with soap.	U	4	
	d)	Distinguish between paints and varnishes.	U	6	
	e)	Describe disadvantages of hard water in sugar industry and paper industry.	A	4	
	f)	Explain purposes of making alloys.	U	2	
Q.6		Attempt any FOUR :			16
	a)	Define roasting of ore. Write purposes of roasting.	U	5	
	b)	Write any four functions of a lubricant.	U	6	
	c)	Define Flash Point, fire point, Acid value and oiliness.	R	6	
	d)	What is sterilization? Explain chlorination process by using chlorine gas and chloramine with chemical reactions.	U	4	
	e)	Give composition, properties and applications of duralumin alloys.	A	2	
	f)	What is varnish? How is it classified? List constituents of varnish.	R	2	

GOVERNMENT POLYTECHNIC, KOLHAPUR – 416004

(An Autonomous Institute of Govt. Of Maharashtra)

SUMMER 2024

EXAM SEAT NO.

LEVEL :- Third

PROGRAM : CE/ME/ ENTC/EE

COURSE CODE : CEG301/MEG301/EIG301/CEF301/MEF301/EIF301/ETE301/EEG302/CE 201

COURSE NAME : Applied Mathematics

MAX. MARKS : 80 TIME : 3 HRS. DATE :- 03 May 2024

Instruction :-

- 1) Answers must be written in the main answer book provided (and supplements if required).
- 2) Illustrate your answers with sketches wherever necessary.
- 3) Use of non-programmable pocket calculator is permissible,
- 4) Mathematical and other tables shall be made available on request.
- 5) Assume and mention suitable additional data if necessary.
- 6) Use of Mobile is strictly prohibited.
- 7) QN- Question No., SQN-Sub Question No. R- Remembering, U- Understanding, A- Application.

QN	S Q N	Question Text	R/ U/ A	CO	Mar ks
Q.1		Attempt any FOUR:			08
	a)	Evaluate : $\int (4x - 7)^{10} .dx$	R	1	
	b)	Evaluate : $\int \frac{1}{x^2 - 9} .dx$	R	1	
	c)	Evaluate : $\int \frac{\sin \sqrt{x}}{\sqrt{x}} .dx$	U	1	
	d)	Evaluate : $\int_2^3 \frac{dx}{2x+1}$	R	1	
	e)	Evaluate : $\int_0^{\frac{\pi}{2}} \frac{dx}{\sqrt{1-x^2}}$	U	1	
	f)	Find the area bounded by the curve $y = \sin x, x = 0, x = \frac{\pi}{2}$ and $x - axis$	A	2	
Q.2		Attempt any FOUR:			16
	a)	Evaluate : $\int \frac{e^x(x+1)}{\cos^2(x.e^x)} dx$	A	1	
	b)	Evaluate : $\int x^2 . \sin x .dx$	A	1	
	c)	Evaluate : $\int \frac{x+1}{(x+2)(x+3)} dx$	A	1	
	d)	Evaluate : $\int \frac{1}{3x^2 + 2x + 5} .dx$	U	1	
	e)	Evaluate : $\int_0^3 \frac{\sqrt{3-x}}{\sqrt{3-x} + \sqrt{x}} .dx$	A	1	
	f)	Find the area bounded by the curve $y = 3x^2$ and line $y = 6x$	A	2	

P.T.O.

Q.3	Attempt any FOUR:			16
a)	Find the area bounded by the curve $y = 8x - x^2$ and x -axis	A	1	
b)	Find the area enclosed by the curve $y = \frac{3}{2x-1}$, x -axis, the ordinates $x = 1$ and $x = 3$	U	2	
c)	Evaluate : $\int_0^{\frac{\pi}{4}} \log(1 + \tan x) dx$	A	1	
d)	Evaluate : $\int_1^e x \cdot \log x \cdot dx$	U	3	
e)	Evaluate : $\int \frac{dx}{5 + 4 \cos x}$	A	2	
f)	Evaluate : $\int \frac{\sec^2 x}{(1 + \tan x)(2 + \tan x)} dx$	A	1	

Q.4	Attempt any FOUR:			08
a)	Define Laplace transform of $f(t)$	R	3	
b)	Find order and degree of the differential equation $\sqrt[3]{\frac{dy}{dx}} = \sqrt[4]{\frac{d^2y}{dx^2}}$	R	2	
c)	State the condition for exact differential equation.	R	2	
d)	Find integrating factor of $\frac{dy}{dx} + y \tan x = \cos^2 x$	U	2	
e)	Find $L\{t \cos 3t\}$	A	3	
f)	Find $L^{-1}\left\{\frac{3s-4}{16-s^2}\right\}$	R	3	

Q.5	Attempt any FOUR :			16
a)	Find Laplace transform of $\cos^3 t$	U	3	
b)	Find $L^{-1}\left\{\frac{2s+1}{s(s+1)}\right\}$	A	3	
c)	Solve the differential equation . $\frac{dy}{dx} = e^{x-y} x^2$	U	2	
d)	Solve : $xy^2 \cdot dy - (x^3 + y^3) dx = 0$ given that $y = 0$ when $x = 1$	A	2	
e)	Find $L^{-1}\left\{\frac{1}{2s^2 + 8s + 3}\right\}$	A	3	
f)	Solve the following differential equation $(4x^3 y^2 + y \cos xy) dx + (2x^4 y + x \cdot \cos xy) dy = 0$	A	2	

Q.6	Attempt any FOUR:			16
a)	Find the Laplace transform of $te^t \cdot \sin t$	U	3	
b)	Find $L\{e^{3t} \cdot \sin 2t \cdot \cos 3t\}$	A	3	
c)	Find inverse Laplace transform of $\frac{2s^2 - 4}{(s+1)(s+2)(s+3)}$	A	3	
d)	Solve: $\frac{dy}{dx} = e^{2x-3y} + 4x^2 e^{-3y}$	U	2	
e)	Solve: $(x+1)\frac{dy}{dx} - y = e^x(x+1)^2$	A	2	
f)	Solve the D. E. : $\left[y\left(1 + \frac{1}{x}\right) + \cos y\right] dx + [x \log x - x \sin y] dy = 0$	A	2	

GOVERNMENT POLYTECHNIC, KOLHAPUR – 416004.

(An Autonomous Institute of Govt. Of Maharashtra)

EVEN TERM END EXAM SUMMER -2024**EXAM SEAT NO.**

--	--	--	--	--	--

LEVEL :- **THIRD**PROGRAM : **INFORMATION TECHNOLOGY**COURSE CODE :- **ITG301**COURSE NAME **APPLIED MATHEMATICS**MAX. MARKS : **80** TIME : **03Hrs.**DATE :- **03/05/2024**

Instruction :-

- 1) Answers must be written in the main answer book provided.(and supplements if required)
- 2) Illustrate your answers with sketches wherever necessary.
- 3) Use of non-programmable pocket calculator is permissible.
- 4) Mathematical and other tables shall be made available on request.
- 5) Assume and mention suitable additional data if necessary.
- 6) Use of Mobile is strictly prohibited.
- 7) QN- Question No., SQN-Sub Question No. R- Remembering, U- Understanding, A- Application.

QN	S Q N	Question Text	R/ U/ A	Co ITG 301	Mar ks														
Q.1		Attempt any FOUR :			08														
	a)	Evaluate, $\int \frac{1}{x \cdot \log x} dx$	U	1															
	b)	Evaluate, $\int_0^2 \frac{5x}{x^2 + 4} dx$	R	1															
	c)	Define standard deviation.	R	2															
	d)	Evaluate, $\int (\log_a a + e^{2 \log x} + e^{x \cdot \log a}) dx$	R	1															
	e)	Evaluate, $\int_{-\pi/2}^{\pi/2} \sin^3 x dx$	R	1															
	f)	Calculate the range of the following data: 2, 3, 1, 10, 6, 31, 17, 20, 24.	R	2															
Q.2		Attempt any FOUR :			16														
	a)	Evaluate, $\int \frac{\sec^2 x}{(1 + \tan x)(2 + \tan x)} dx$	A	1															
	b)	Evaluate the following integral by using property $\int_0^{\pi/2} \frac{\sin x}{\sin x + \cos x} dx$	A	1															
	c)	Calculate the mean deviation about the mean from the following data: <table border="1" style="margin-left: auto; margin-right: auto;"> <tr> <td>X</td> <td>3</td> <td>4</td> <td>5</td> <td>6</td> <td>7</td> <td>8</td> </tr> <tr> <td>F</td> <td>4</td> <td>9</td> <td>10</td> <td>8</td> <td>6</td> <td>3</td> </tr> </table>	X	3	4	5	6	7	8	F	4	9	10	8	6	3	A	2	
X	3	4	5	6	7	8													
F	4	9	10	8	6	3													
	d)	Evaluate, $\int \frac{1}{3 + 2x - x^2} dx$	A	1															
	e)	Evaluate, $\int_0^1 x \cdot \tan^{-1} x dx$	U	1															
	f)	Evaluate, $\int x \cdot \sin x dx$	U	1															
Q.3		Attempt any FOUR :			16														
	a)	Evaluate, $\int \frac{x^2 + 1}{(x+1)(x+2)(x+3)} dx$	A	1															

	b)	Evaluate $\int_0^{\pi/4} \sin 4x \cdot \sin 3x \, dx$	A	1													
	c)	In two factories A and B in the same industrial area the average daily wages in Rs. and standard deviations are as follows: <table border="1" data-bbox="277 329 888 468"> <thead> <tr> <th>Factory</th> <th>Average Wage</th> <th>S.D</th> </tr> </thead> <tbody> <tr> <td>A</td> <td>345</td> <td>50</td> </tr> <tr> <td>B</td> <td>285</td> <td>45</td> </tr> </tbody> </table> <p>Which factory is more consistent? Which factory is less consistent?</p>	Factory	Average Wage	S.D	A	345	50	B	285	45	A	2				
Factory	Average Wage	S.D															
A	345	50															
B	285	45															
	d)	Calculate the standard deviation of the following data: <table border="1" data-bbox="253 644 1263 741"> <thead> <tr> <th>Class</th> <th>0-20</th> <th>20-40</th> <th>40-60</th> <th>60-80</th> <th>80-100</th> </tr> </thead> <tbody> <tr> <td>Frequency</td> <td>20</td> <td>130</td> <td>220</td> <td>70</td> <td>60</td> </tr> </tbody> </table>	Class	0-20	20-40	40-60	60-80	80-100	Frequency	20	130	220	70	60	A	2	
Class	0-20	20-40	40-60	60-80	80-100												
Frequency	20	130	220	70	60												
	e)	Evaluate, $\int \frac{(1 + \sqrt{x})^2}{\sqrt{x}} \, dx$	A	1													
	f)	Evaluate, $\int \frac{\sec^2 x}{3 \tan^2 x - 2 \tan x - 5} \, dx$	A	1													

EXAM SEAT NO.

--	--	--	--	--	--

LEVEL :- THIRD

PROGRAM : Information Technology

COURSE CODE :- ITG301

COURSE NAME :- APPLIED MATHEMATICS

MAX. MARKS : 80 TIME : 03 Hrs

DATE :- 03/5/2024

QN	S Q N	QuestionText	R/ U/ A	Co ITG3 01.	Ma rks
Q.4		Attempt any FOUR :			08
	a)	Find order and degree of the differential equation $\frac{d^2y}{dx^2} = (y + \frac{dy}{dx})^{3/2}$	R	3	
	b)	Show that $y = ax^2$ is the solution of the differential equation $x \frac{dy}{dx} = 2y$	R	3	
	c)	Solve $(1+x^2)dy - (1+y^2)dx = 0$	U	3	
	d)	9 tickets marked with a number from 1 to 9 are placed in a bag. What is the probability that the number on the ticket is odd?	U	4	
	e)	An unbiased coin is tossed 6 times Find the probability of getting atleast 4 heads.	R	4	
	f)	A random variable X follows a Poisson distribution with mean 3.4. Find $P(x=6)$	R	4	
Q.5		Attempt any FOUR :			16
	a)	Solve $3e^x \tan y dx + (1 - e^x) \sec^2 y = 0$	A	3	
	b)	Solve $x(x+y) dy - y^2 dx = 0$	U	3	
	c)	Solve $y^3 \sec^2 x dx + (3y^2 \tan x - \sec^2 x) dy = 0$	A	3	
	d)	If $P(A) = \frac{1}{2}$, $P(B) = \frac{1}{3}$, $P(A \cap B) = \frac{7}{12}$, Find $P(A' \cap B')$	A	4	
	e)	The probability that a man aged 65 will live to 75 is 0.65. What is the probability that out of 10 men which are now 65, 7 will live to 75?	U	4	
	f)	In a certain examination 500 students appeared average score is 68 with S.D. 8. Find the number of students scoring more than 60. (Given Area from $z=0$ to $z=1$ is 0.3413)	A	4	
Q.6		Attempt any FOUR :			16
	a)	Solve $(x + y + 1)^2 \frac{dy}{dx} = 1$	A	3	
	b)	Solve $(1+x) \frac{dy}{dx} - y = e^x(x + 1)^2$	U	3	
	c)	Two cards are drawn at random from a well shuffled pack of 52 cards. Find the probability that the two cards drawn form a pair of King and Queen of the same suit.	U	4	
	d)	Number of road accidents follows a Poisson's distribution with mean 5. Find the probability that in a certain month, number of accidents on the highway will be more than 3.	U	4	
	e)	If 30% of the bulbs produced are defective, find probability that out of 4 bulbs selected, at the most two are defective.	U	4	
	f)	Verify that $y = \sin(\log x)$ is a solution of differential equation $x^2 \frac{d^2y}{dx^2} + x \frac{dy}{dx} + y = 0$	A	3	

GOVERNMENT POLYTECHNIC, KOLHAPUR – 416004.

(An Autonomous Institute of Govt. Of Maharashtra)

SUMMER- 2024

EXAM SEAT NO.

--	--	--	--	--	--

LEVEL :- Third

PROGRAM : CE/ME/IT/EE/ET/MT

COURSE CODE :- CCH301

COURSE NAME :- APPLIED MATHEMATICS

MAX. MARKS : 70

TIME : 03 Hrs

DATE :- 21/5/2024

QN	S Q N	Question Text	R/ U/ A	Co	Ma rks
Q.4		Attempt any FOUR : (2 X 4)			08
	a)	Show that the root of the equation $x^3 - 6x + 3 = 0$ lies between 2 and 3.	R	3	
	b)	Solve by using Jacobi's method (only one iteration) $5x + 2y + z = 12, x + 4y + 2z = 15, x + 2y + 5z = 20$	U	3	
	c)	If a random variable has a Poisson's distribution such that $P(2) = P(3)$ then find $P(5)$.	U	4	
	d)	Find $L\{5 + 2t - e^{-2t}\}$	R	5	
	e)	Find $L\{\sin^2 t\}$	U	5	
	f)	Find $L^{-1}\left\{\frac{3s+2}{s^2+4}\right\}$	U	5	
Q.5		Attempt any FOUR : (4 X 4)			16
	a)	Using Bisection method to find the approximate root of the equation $x^3 + 5x + 1 = 0$ (Take 3 iterations only)	A	3	
	b)	Using Regula-Falsi method to find the approximate root of the equation $x^3 + 2x^2 - 8 = 0$ (Take 3 iterations only)	A	3	
	c)	Using Newton Raphson method to evaluate $\sqrt[3]{28}$.	U	3	
	d)	A sample of 1000 bulbs is distributed normally with mean life 1620 hrs and standard deviation 300 hrs. Find the number of bulbs which would die out after a useful life of 900 hrs. For $z = 2.4$ area is 0.4918.	U	4	
	e)	Find $L\{e^{2t} \cos 3t \cdot \sin 2t\}$	U	5	
	f)	Find $L^{-1}\left\{\frac{s+2}{s^2-4s+13}\right\}$	A	5	
Q.6		Attempt any TWO : (6 X 2)			12
	a)	Solve by using Gauss-seidel method (Take only 3 iterations) $2x + y - 2z = 17, 3x + 20y - z = 18, 2x - 3y + 20z = 25$	A	3	
	b)	i) An unbiased coin is tossed 6 times. Find the probability of getting exactly 2 heads. ii) If 3% of electric bulbs manufactured by a company are defective, then find the probability that in a sample of 100 bulbs exactly 5 bulbs are defective.	A	4	
	c)	i) Find $L\{t \cdot e^t \cdot \sin 2t\}$ ii) Find $L^{-1}\left\{\frac{3s+1}{(s-1)(s+1)}\right\}$	A	5	

GOVERNMENT POLYTECHNIC, KOLHAPUR – 416004.

(An Autonomous Institute of Govt. Of Maharashtra)

SUMMER-2024

EXAM SEAT NO.

LEVEL : -Third

COURSE CODE :- CCH301

MAX. MARKS : 70

PROGRAM : CE/ME/IT/EE/ET/MT

COURSE NAME :-APPLIED MATHEMATICS

TIME : 03 Hrs

DATE :- 21 / 5 / 2024

Instruction :-

- 1) Answers of two sections must be written in separate section answer book provided.
- 2) Illustrate your answers with sketches wherever necessary.
- 3) Use of non-programmable pocket calculator is permissible.
- 4) Mathematical and other tables shall be made available on request.
- 5) Assume and mention suitable additional data if necessary.
- 6) Use of Mobile is strictly prohibited.
- 7) QN- Question No., SQN-Sub Question No. R- Remembering, U- Understanding, A- Application.

QN	S Q N	Question Text	R/ U/ A	Co	Ma rks
Q.1		Attempt any THREE: (2 X 3)			06
	a)	Evaluate, $\int \frac{1}{2x+5} dx$	R	1	
	b)	Evaluate, $\int \sin^2 x dx$	R	1	
	c)	Evaluate, $\int_0^1 \frac{1}{\sqrt{1-x^2}} dx$	U	2	
	d)	Evaluate, $\int_0^\infty e^{-x} dx$	U	2	
	e)	Solve, $x dy - y dx = 0$	R	3	
Q.2		Attempt any FOUR: (4 X 4)			16
	a)	Evaluate, $\int \frac{1}{\sqrt{3-x-x^2}} dx$	U	1	
	b)	Evaluate, $\int \sin^5 x \cdot \cos x dx$	U	1	
	c)	Evaluate, $\int_1^4 \frac{\sqrt[3]{9-x}}{\sqrt[3]{9-x} + \sqrt[3]{x+4}} dx$	A	2	
	d)	Solve, $3e^x \tan y dx + (1-e^x) \sec^2 y dy = 0$	U	3	
	e)	Evaluate, $\int \frac{\cos x}{(2+\sin x)(3+\sin x)} dx$	U	2	
	f)	Solve, $\frac{dy}{dx} + y \cot x - \operatorname{cosec} x = 0$	U	3	
Q.3		Attempt any TWO: (6 X 2)			12
	a)	Evaluate, i) $\int \frac{\cos x}{4+\sin^2 x} dx$ ii) $\int_{\frac{\pi}{6}}^{\frac{\pi}{4}} \cot^2 x dx$	U	1	
	b)	Solve, $(e^x + 2xy^2) dx + (a^y + 2x^2y + 3xy^2) dy = 0$	U	2	
	c)	Evaluate, $\int \frac{\sec^2 x}{(1+\tan x)(2+\tan x)} dx$	A	1	

P.T.O.